

MTE Corporation

MTE

DCA Link Chokes

USER MANUAL

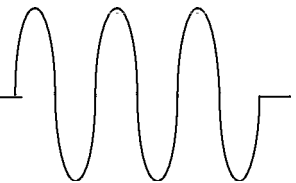

PART NO. INSTR – 021
REL. 060612

IMPORTANT USER INFORMATION

NOTICE

MTE Series A DC Link Chokes are components designed to improve the reliability of adjustable frequency drives and a wide variety of other types of power electronic equipment. In addition they provide current harmonic mitigation and protection for inverters. MTE Series A DC Link Chokes are available in a large number of current ratings and a variety of inductance values. The suitability of a link choke for a specific application must therefore be ultimately determined by the customer. In no event will MTE Corporation assume responsibility or liability for any direct or consequential damages resulting from the use or application of Series A DC Link Chokes. Nor will MTE Corporation assume patent liability with respect to the use of information, circuits or equipment described in this instruction manual.

TABLE OF CONTENTS

1. Safety	4
2. Introduction	5
3. Model Number Codes	6
4. Specifications	8
Altitude Derating Curve	9
Dimensions & Technical Data	10
Open Type	10
Nema Type 1	13
5. Installation Instructions	17
Power Wiring Connection	18
Grounding	19
Typical Interconnection Diagrams	20
6. Startup.....	21

1. IMPORTANT SAFETY INFORMATION

WARNING

ONLY A QUALIFIED ELECTRICIAN CAN CARRY OUT THE ELECTRICAL INSTALLATION OF LINE/LOAD SERIES A DC LINK CHOKES

WARNING

High voltage is used in the operation of Link Chokes. Use Extreme caution to avoid contact with high voltage when operating, installing or repairing equipment containing link Chokes. **INJURY OR DEATH MAY RESULT IF SAFETY PRECAUTIONS ARE NOT OBSERVED.**

Link Chokes are used in conjunction with inverters, or other electrical equipment that may feedback lethal voltages. Follow the safety instructions in the equipment used with the link chokes in addition to the safety instruction in this manual.

WARNING

The opening of the branch circuit protective device may be an indication that a fault current has been interrupted. To reduce the risk of fire or electrical shock, Link Chokes should be examined and replaced if damaged.

WARNING

An upstream disconnect/protection device must be used as required by the National Electrical Code (NEC).

WARNING

Even if the upstream disconnect/protection device is open, a drive or inverter down stream of the line/load link chokes may feed back high voltage to the reactor. The inverter or drive safety instructions must be followed. **INJURY OR DEATH MAY RESULT IF THE DRIVE SAFETY PRECAUTIONS ARE NOT OBSERVED.**

WARNING

The frame of Link Chokes must be grounded to at least at one of the mounting holes.

WARNING

Only spare parts obtained from MTE Corporation or an authorized MTE distributor can be used

2. INTRODUCTION

This manual was specifically developed to assist in the installation, interconnection and operation of MTE Corporation DCA Link Chokes

This manual is intended for use by personnel experienced in the operation and maintenance of electronic drives, inverters and similar types of power electronic equipment. Because of the high voltages required by the equipment connected to Link Chokes and the potential dangers presented by rotating machinery, it is essential that all personnel involved in the operation and maintenance of Link Chokes know and practice the necessary safety precautions for this type of equipment. Personnel should read and understand the instructions contained in this manual before installing, operating or servicing Link Chokes and the drive to which the link chokes is connected.

Upon Receipt of a Reactor:

MTE Link Chokes have been subjected to demanding factory tests before shipment. Carefully inspect the shipping container for damage that may have occurred in transit. Then unpack the filter and carefully inspect for any signs of damage. Save the shipping container for future transport of the reactor.

In the event of damage, please contact and file a claim with the freight carrier involved immediately.

If the equipment is not going to be put into service upon receipt, cover and store the link chokes in a clean, dry location. After storage, ensure that the equipment is dry and that no condensation has accumulated on the link chokes before applying power.

Repair/Exchange Procedure

MTE Corporation requires a Returned Material Authorization Number before it can accept any Link Chokes that qualify for return or repair. If problems or questions arise during installation, setup, or operation of the filter, please call us for assistance at:

Phone: 1-262-253-8200

FAX: 1-262-253-8222

Model Code Part Number Configuration

Model Number Code System:

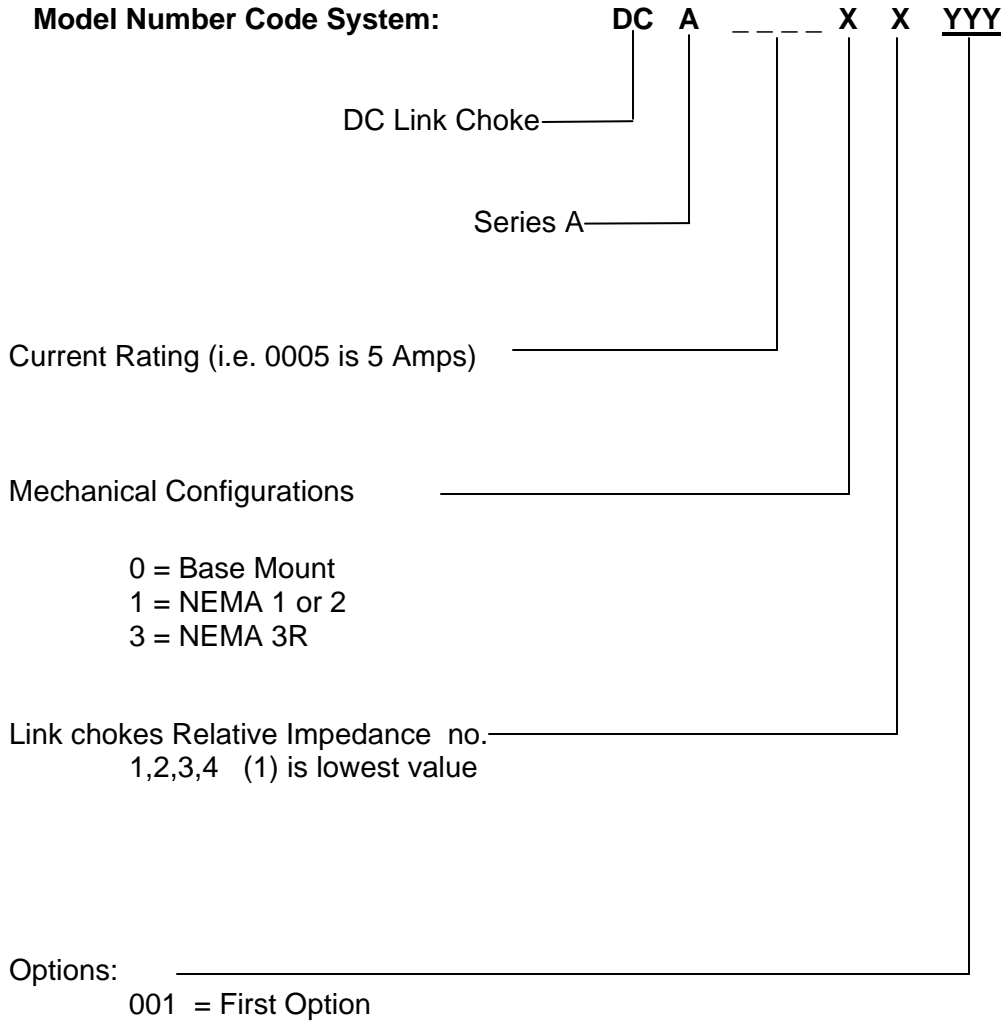

Product Specifications

Series A DC Link Chokes

Approvals:	Component Recognition: Per UL 508, cUL per CSA C22.2 14-M91
Maximum Voltage:	1000 Volts DC
Ampere Ratings:	4 amps thru 200 amps standard
Overload Rating:	150 % of max RMS current for 1 minute
Maximum Altitude:	1000 meters
Temperature Rise:	85 C by TC & 105 C by resistance except as noted. 125 C by TC & 145 C by resistance part numbers DCA00805, DCA00923, DCA01504 and DCA02002
Maximum Ambient:	50 C open chokes 40 C enclosed chokes
Insulation System:	UL Class 155 except as noted UL Class 200 part numbers DCA00805, DCA00923, DCA01504 and DCA02002
Ripple Current:	10% p-p at 360 Hz maximum
Selection Basis:	DC amps, RMS amps
Thermal Current:	DC amps x 1.0353

Chart 1

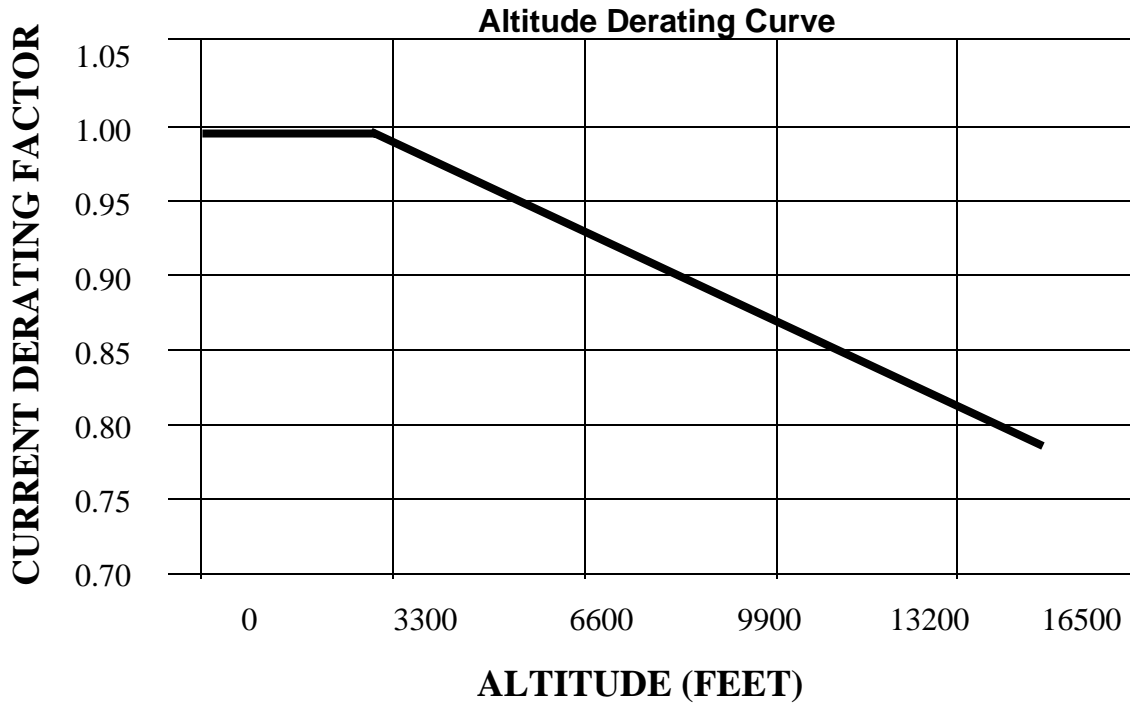

Dimensions Series A DC Link Chokes

Cat. No.	Figure	A	B	C	D	E	F
DCA000204	1	3.75	3.25	2	N/A	3.13	.187 DIA
DCA000402	1	3.75	3.25	2	N/A	3.13	.187 DIA
DCA000403	1	3.75	3.25	2	N/A	3.13	.187 DIA
DCA000404	2	3.81	4.5	2.82	2	3.13	.203 X .328
DCA000902	1	3.75	3.25	2	N/A	3.13	.187 DIA
DCA000903	2	3.81	4.5	2.82	2	3.13	.203 X .328
DCA000904	2	4.63	5.25	4	2.5	3.73	.203 X .328
DCA001201	1	3.75	3.25	1.75	N/A	3.13	.187 DIA
DCA001203	2	3.81	4.5	2.82	2	3.13	.203 X .328
DCA001802	2	3.81	4.5	2.82	2	3.13	.203 X .328
DCA001803	2	3.81	4.5	3.75	3	3.13	.203 X .328
DCA001804	2	4.63	5.25	4	2.5	3.75	.203 X .328
DCA001805	2	4.63	5.25	5.25	4	3.75	.203 X .328
DCA002503	2	3.81	4.5	3.75	3	3.13	.203 X .328
DCA002504	2	3.81	4.5	3	2.5	3.13	.203 X .328
DCA002505	2	4.63	5.25	5.25	4	3.13	.203 X .328
DCA003201	2	3.81	4.5	3.32	2.5	3.13	.203 X .328
DCA003202	2	4.63	5.25	4.25	3	3.75	.203 X .328
DCA003203	2	4.63	5.25	5.25	3	3.75	.203 X .328
DCA004001	2	3.81	4.5	3	2.5	3.13	.203 X .328
DCA004002	2	3.81	4.5	3.75	3	3.13	.203 X .328
DCA004003	2	4.63	5.25	4	2.5	3.75	.203 X .328
DCA004004	2	6.5	6.55	6	3.38	5.31	.28 X .52
DCA005001	2	4.63	5.25	4	2.5	3.75	.203 X .328
DCA005003	2	4.63	5.25	5.25	4	3.75	.203 X .328
DCA005004	2	6.5	5.5	6	3.38	5.31	.28 X .52
DCA006201	2	4.63	4	5	2.5	3.75	.203 X .328
DCA006202	2	4.63	4	7.25	4	3.75	.203 X .328
DCA008002	2	4.63	4	6.5	4	3.75	.203 X .328
DCA008005	2	7.5	6.28	6.0	3.62	6.75	.281 X .562
DCA009201	2	4.63	4	6	3	3.75	.203 X .328
DCA009202	2	6.5	5.5	6.75	3.75	5.31	.281 X .562
DCA009203	2	6.5	5.5	7	4.63	5.31	.281 X .562
DCA011002	2	6.5	5.5	6	3	5.31	.281 X .562
DCA011003	2	6.5	5.5	6.63	3.63	5.31	.281 X .562
DCA012502	2	6.5	5.5	6.5	3.31	5.31	.281 X .562
DCA015002	2	6.5	5.5	7.5	3.38	5.31	.281 X .562
DCA015004	2	7.5	6.5	8.75	5.13	6.75	.281 X .562
DCA020002	2	7.5	6.5	9	3.63	6.75	.281 X .562

Dimensions

Series A DC Link Chokes

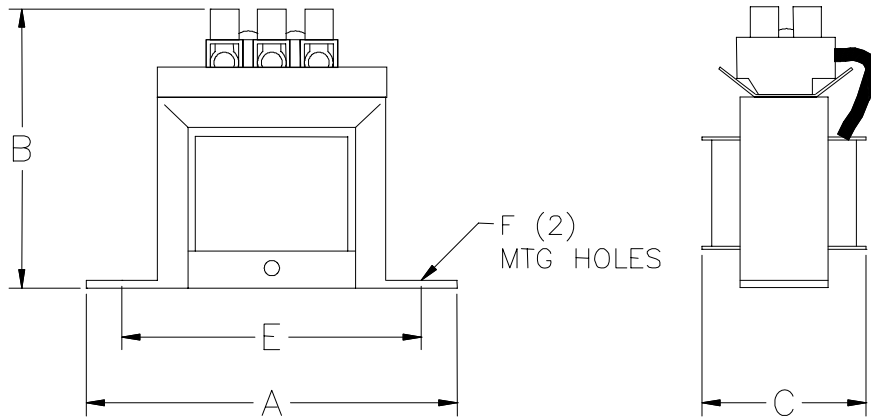

FIGURE 1

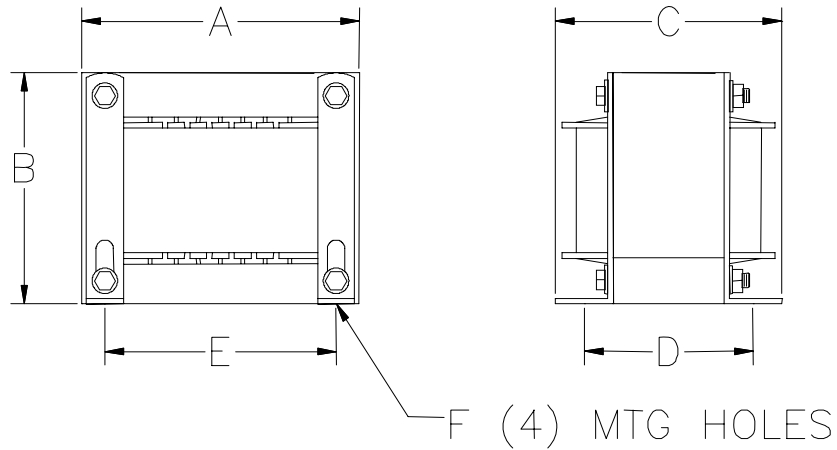

FIGURE 2

Technical Data Series A DC Link Chokes

Cat. No.	DC Amps	mH	Watts	Lug Size	Torque	Unit weight Pounds
DCA000204	2	50	5	22-14	4.5	2
DCA000402	4	12	5	22-14	4.5	2
DCA000403	4	15	6	22-14	4.5	2
DCA000404	4	25	9	18-4	20	4
DCA000902	9	3.22	7	22-14	4.5	2
DCA000903	9	7.5	11	18-4	20	4
DCA000904	9	11.5	16	18-4	20	7
DCA001201	12	1	5	22-14	4.5	1
DCA001203	12	4	11	18-4	20	4
DCA001802	18	1.375	9	18-4	20	4
DCA001803	18	2.75	16	18-4	20	7
DCA001804	18	3.75	17	18-4	20	8
DCA001805	18	6	20	18-4	20	13
DCA002503	25	1.275	13	18-4	20	7
DCA002504	25	1.75	13	18-4	20	5
DCA002505	25	4	16	18-4	20	13
DCA003201	32	0.85	11	18-4	20	5
DCA003202	32	1.62	14	18-4	20	10
DCA003203	32	2.68	21	18-4	20	14
DCA004001	40	0.5	14	18-4	20	5
DCA004002	40	0.75	15	18-4	20	7
DCA004003	40	1	17	18-4	20	8
DCA004004	40	2	29	18-4	20	21
DCA005001	50	0.625	18	18-4	20	8
DCA005003	50	1.35	21	18-4	20	15
DCA005004	50	2	30	6-0	6-4(45) & 2-0 (50)	25
DCA006201	62	0.32	17	6-0	6-4(45) & 2-0 (50)	8
DCA006202	62	0.61	20	6-0	6-4(45) & 2-0 (50)	14
DCA008002	80	0.4	25	6-0	6-4(45) & 2-0(50)	14
DCA008005	80	1.25		6-0	6-4(45) & 2-0(50)	35
DCA009201	92	0.2	19	6-0	6-4(45) & 2-0(50)	10
DCA009202	92	0.6	34	6-0	6-4(45) & 2-0(50)	23
DCA009203	92	1	48	6-0	6-4(45) & 2-0(50)	32
DCA011002	110	0.3	38	6-0	6-4(45) & 2-0(50)	22
DCA011003	110	0.45	45	6-0	6-4(45) & 2-0(50)	22
DCA012502	125	0.22	27	6-0	6-4(45) & 2-0(50)	23
DCA015002	150	0.22	36	2-0000	150	23
DCA015004	150	0.65		2-0000	150	52
DCA020002	200	0.21	50	2-0000	150	39

DCA Nema 1 enclosed units

DCA NEMA1 Enclosed P.N.	NEMA 1 Enclosure	Enclosed Weight #	Figure
DCA000214	CAB -8	9	Fig. 4
DCA000412	CAB -8	9	Fig. 4
DCA000413	CAB -8	9	Fig. 4
DCA000414	CAB -8	11	Fig. 4
DCA000912	CAB -8	9	Fig. 4
DCA000913	CAB -8	11	Fig. 4
DCA000914	CAB -8	14	Fig. 4
DCA001211	CAB -8	8	Fig. 4
DCA001213	CAB -8	11	Fig. 4
DCA001812	CAB -8	11	Fig. 4
DCA001813	CAB -8	14	Fig. 4
DCA001814	CAB -8	15	Fig. 4
DCA001815	CAB -13V	31	Fig. 5
DCA002513	CAB -8	14	Fig. 4
DCA002514	CAB -8	12	Fig. 4
DCA002515	CAB -13V	31	Fig. 5
DCA003211	CAB -8	12	Fig. 4
DCA003212	CAB -13V	28	Fig. 5
DCA003213	CAB -13V	32	Fig. 5
DCA004011	CAB -8	12	Fig. 4
DCA004012	CAB -8	14	Fig. 4
DCA004013	CAB -8	15	Fig. 4
DCA004014	CAB -13V	39	Fig. 5
DCA005011	CAB -8	15	Fig. 4
DCA005013	CAB -13V	33	Fig. 5
DCA005014	CAB -13V	43	Fig. 5
DCA006211	CAB -13V	26	Fig. 5
DCA006212	CAB -13V	32	Fig. 5
DCA008012	CAB -13V	32	Fig. 5
DCA008015	CAB -13V	53	Fig. 5
DCA009211	CAB -13V	28	Fig. 5
DCA009212	CAB -13V	41	Fig. 5
DCA009213	CAB -13V	50	Fig. 5
DCA011012	CAB -13V	40	Fig. 5
DCA011013	CAB -13V	40	Fig. 5
DCA012512	CAB -13V	41	Fig. 5
DCA015012	CAB -13V	41	Fig. 5
DCA015014	CAB -13V	70	Fig. 5
DCA020012	CAB -13V	57	Fig. 5

DCA Nema 3R Enclosed units

DCA NEMA1 Enclosed P.N.	NEMA 3R Enclosure	Enclosed Weight #	Figure
DCA000234	CAB 12C	70	Fig. 6
DCA000432	CAB 12C	70	Fig. 6
DCA000433	CAB 12C	70	Fig. 6
DCA000434	CAB 12C	72	Fig. 6
DCA000932	CAB 12C	70	Fig. 6
DCA000933	CAB 12C	72	Fig. 6
DCA000934	CAB 12C	75	Fig. 6
DCA001231	CAB 12C	69	Fig. 6
DCA001233	CAB 12C	72	Fig. 6
DCA001832	CAB 12C	72	Fig. 6
DCA001833	CAB 12C	75	Fig. 6
DCA001834	CAB 12C	76	Fig. 6
DCA001835	CAB 12C	81	Fig. 6
DCA002533	CAB 12C	75	Fig. 6
DCA002534	CAB 12C	73	Fig. 6
DCA002535	CAB 12C	81	Fig. 6
DCA003231	CAB 12C	73	Fig. 6
DCA003232	CAB 12C	78	Fig. 6
DCA003233	CAB 12C	82	Fig. 6
DCA004031	CAB 12C	73	Fig. 6
DCA004032	CAB 12C	75	Fig. 6
DCA004033	CAB 12C	76	Fig. 6
DCA004034	CAB 12C	89	Fig. 6
DCA005031	CAB 12C	76	Fig. 6
DCA005033	CAB 12C	83	Fig. 6
DCA005034	CAB 12C	93	Fig. 6
DCA006231	CAB 12C	76	Fig. 6
DCA006232	CAB 12C	82	Fig. 6
DCA008032	CAB 12C	82	Fig. 6
DCA008035	CAB 12C	103	Fig. 6
DCA009231	CAB 12C	78	Fig. 6
DCA009232	CAB 12C	91	Fig. 6
DCA009233	CAB 12C	100	Fig. 6
DCA011032	CAB 12C	90	Fig. 6
DCA011033	CAB 12C	90	Fig. 6
DCA012532	CAB 12C	91	Fig. 6
DCA015032	CAB 12C	91	Fig. 6
DCA015034	CAB 12C	120	Fig. 6
DCA020032	CAB 12C	107	Fig. 6

Enclosure Drawings Series A DC Link Chokes NEMA 1

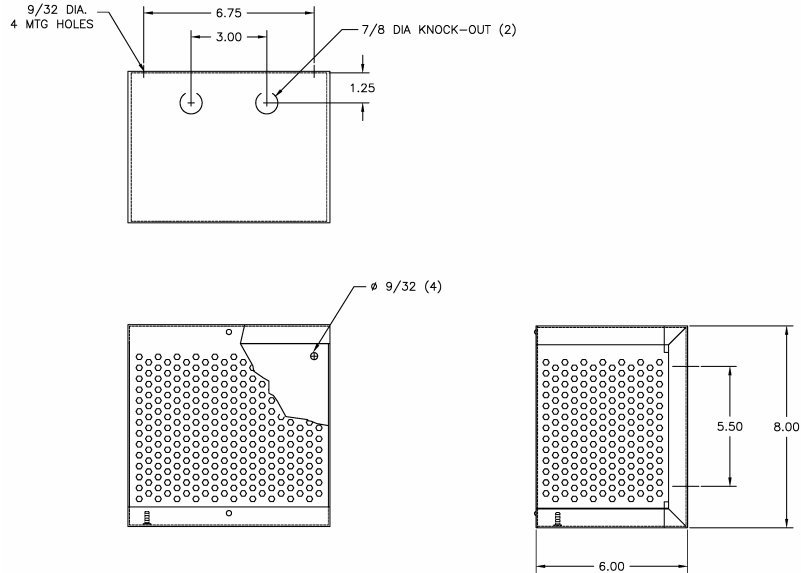

Fig 4 Cab -8

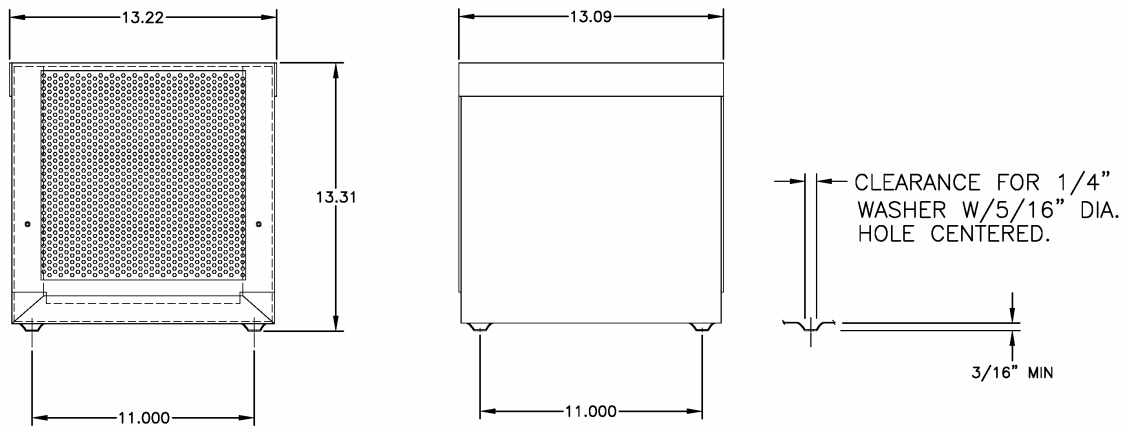

Fig 5 Cab 13V

Enclosure Drawings Series A DC Link Chokes NEMA 3R

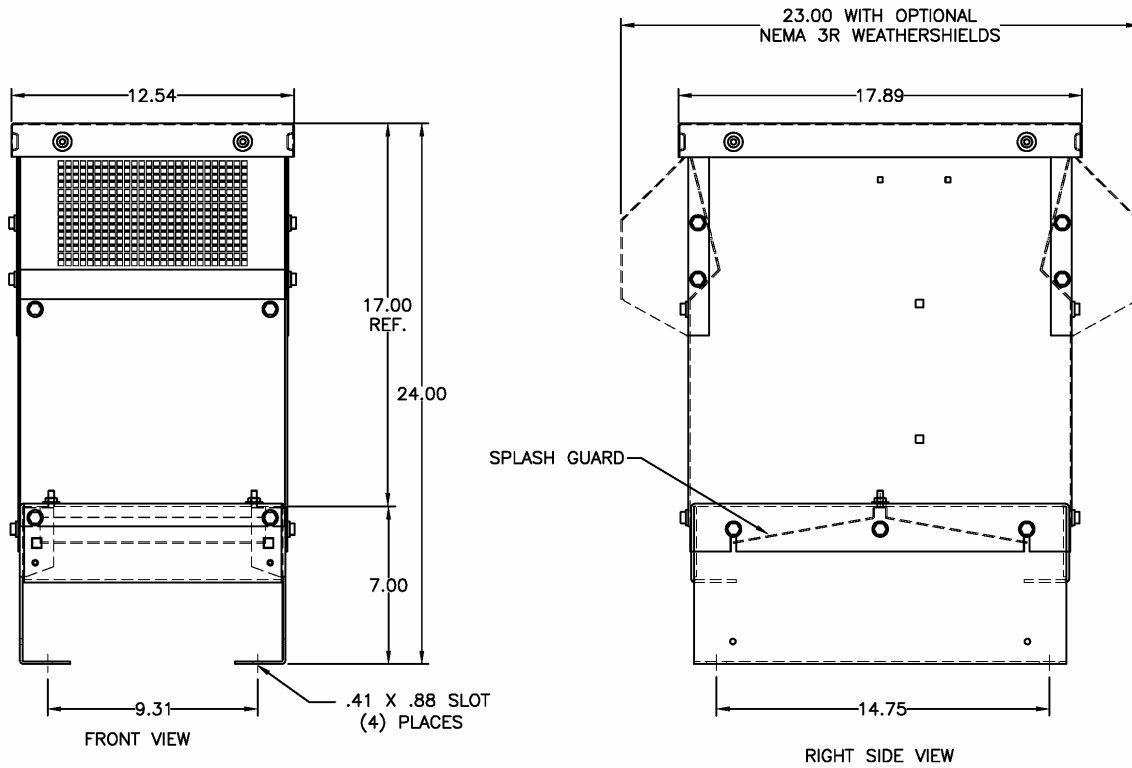

Fig 6 Cab 12C

5. INSTALLATION INSTRUCTIONS

Open Link Choke Installation

MTE Link Chokes are available in open construction and in NEMA 1 enclosures. Open Link Chokes are designed for mounting within an appropriate electrical equipment enclosure. Link Chokes are designed for mounting in both a vertical and horizontal position. Include the power dissipation of the link chokes along with all the other components located in the enclosure to determine the internal temperature rise and cooling requirements of the enclosure.

Link Chokes may be located in any region of the enclosure where the ambient temperature does not exceed 45 degrees C. Allow a minimum side clearances of four (4) inches and vertical clearances of six (6) inches for proper heat dissipation and access. Do not locate the link chokes next to resistors or any other component with operating surface temperatures above 125 degree C.

Select a well ventilated, dust-free area away from direct sunlight, rain or moisture. Do not install in or near a corrosive environment. Avoid locations where the link chokes will be subjected to excessive vibrations.

NEMA 1 Enclosed Link choke Installation

MTE Link Chokes mounted in enclosures with part number, CAB-8, are designed for wall mounting. All other enclosures are designed for floor mounting.

WARNING

MTE NEMA 1 enclosure is designed for floor mounting must be mounted with the enclosure base horizontal for proper ventilation. Wall mounting a floor mounted enclosure with the base against the wall will cause the link chokes to over heat resulting in equipment damage.

Allow a minimum side, front, and back clearances of twelve (12) inches and vertical clearances of eighteen (18) inches for proper heat dissipation and access. Do not locate the enclosure next to resistors or any other component with operating surface temperatures above 125 degree C.

Select a well ventilated, dust-free area away from direct sunlight, rain or moisture where the ambient temperature does not exceed 40 degrees C.

Do not install in or near a corrosive environment.

Avoid locations where the link chokes will be subjected to excessive vibrations.

Where desirable, enclosures may be mounted on vibration isolating pads to reduce audible noise. Standard vibration control pads made from neoprene or natural rubber and selected for the weight of the enclosed link chokes are effective.

Power Wiring Connection

WARNING

Input and output wiring to the link chokes should be performed by authorized personnel in accordance with the NEC and all local electrical codes and regulations.

Verify that the inverter to which the link choke is to be connected is in agreement with the nameplate data on the link choke. Wiring shall be per the requirements of the NEC and all local electrical codes and regulations. Refer to the drive, inverter, or other electrical equipment user manual for selection of the correct wiring terminals.

Link chokes are designed for use with copper conductors with a minimum temperature rating of 75 degrees C. Table 2 lists the wire range and terminal torque requirements for the power input and output connections by link chokes part number.

Refer to Figure 7 for typical electrical diagram describing the application of Link Chokes in inverter drive applications. For Link Chokes supplied as a component part of a drive system or a component part of power electronic apparatus follow the interconnection diagram supplied by the System Engineer.

Where desirable, a flexible conduit connection to the link chokes enclosure should be made to reduce audible noise.

WARNING

Failure to connect Link Chokes supplied as a component part of a drive system or other power electronic system according to the system interconnection diagram supplied by the System Engineer will result in equipment damage, injury, or death.

Grounding

A stud is provided on enclosed Link Chokes for grounding the enclosure. The enclosure must be grounded. Open Link Chokes must be grounded at the designated grounding terminal or the link chokes mounting holes if no designated grounding terminal is provided.

WARNING

The frame of Link Chokes must be grounded at the designated grounding terminal or one of the link chokes mounting holes if no designated grounding terminal is provided. The enclosure of Link Chokes supplied in enclosures must be grounded. INJURY OR DEATH MAY RESULT IF SAFETY PRECAUTIONS ARE NOT OBSERVED.

Typical Dc link Choke Wiring

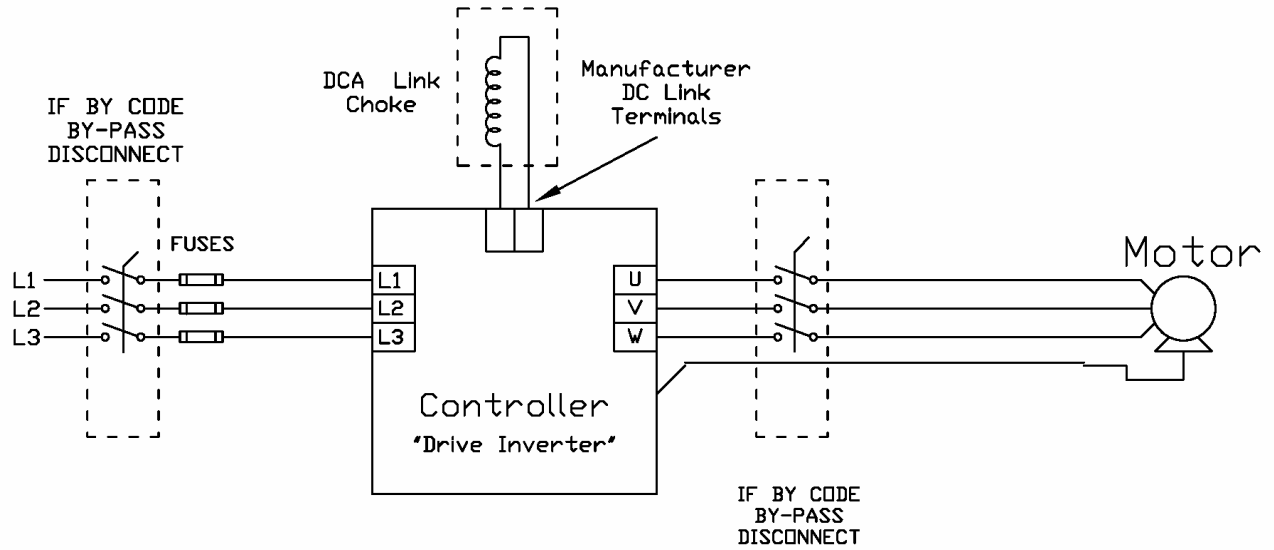

Figure 7

6. STARTUP

Safety Precautions

Before startup, observe the following warnings and instructions:

WARNING

A Link choke is at DC bus potential when the inverter is connected to the utility. This voltage is extremely dangerous and may cause death or severe injury if you come in contact with it.

WARNING

High voltage is used in the operation of Link Chokes. Use Extreme caution to avoid contact with high voltage when operating, installing or repairing equipment containing Link Chokes. Link Chokes are used in conjunction with inverters, or other electrical equipment that may feedback lethal voltages.

Follow the safety instructions in the equipment used with the link chokes in addition to the safety instruction in this manual.

INJURY OR DEATH MAY RESULT IF SAFETY PRECAUTIONS ARE NOT OBSERVED.

7. Sequence of Operation

1. Read and follow safety precautions.
2. After installation, ensure that:
 - All Link choke ground terminals are connected to ground.
 - Power wiring to the utility, drive and motor is in accordance with the interconnection diagrams supplied by the System Engineer per code requirements.
3. Check that moisture has not condensed on the Reactor. If moisture is present, do not proceed with startup until the moisture has been removed.
4. Proceed with startup according to the instructions provided by the system supplier.

WARNING

Link Chokes are a component part of an electrical system. Do not proceed with startup until the system startup instructions provided by the System Engineer are understood and followed. Injury, death and damage to equipment may result if the system startup instructions are not followed.

WARNING

Use extreme caution to avoid contact with line voltage when checking for power.

INJURY OR DEATH MAY RESULT IF SAFETY PRECAUTIONS ARE NOT OBSERVED.

DCA Link Choke User Manual		INSTR-021
Revision	Date	Revision History
---	5/16/05	New document written by Wayne Walcott.
001	06/12/06	Rev by WRW: Added data to page 22, fixed DC amps page 16