

Harmonic Mitigation in Variable Frequency Drives: 6-Pulse Drive with Matrix AP Harmonic Filter vs. AFE Drive

December 18, 2012

Todd Shudarek, Principal Engineer

MTE Corporation
N83 W13330 Leon Road
Menomonee Falls WI 53051
www.mtecorp.com

Abstract

The proliferation of variable frequency drives (VFDs) has brought increased attention to harmonic effects created by drives. A standard 6-pulse drive without any harmonic mitigation technology may interfere with neighboring equipment, reduce equipment life, and negatively impact the utility power quality. Under some circumstances the total harmonic current distortion (THID) may approach the level of the fundamental current. Some drive manufacturers recommend Active Front End (AFE) drives to combat these effects. An alternative solution is the use of a traditional 6-pulse drive equipped with a passive harmonic filter; however, typical passive harmonic filters experience reduced effectiveness at loads less than 100%. With the introduction of adaptive passive technology, the Matrix AP harmonic filter maintains strong harmonic filtering performance across a wide range of loads. This paper compares the performance of a 20 HP AFE drive with the performance of a standard 30 HP 6-pulse drive equipped with a 44 amp Matrix AP harmonic filter.

The 6-pulse drive with Matrix AP harmonic filter outperformed the AFE drive in the following important areas:

- **Harmonic performance under balanced line conditions:** 2-9% better THID performance 25-75% loads and similar performance (about 4% THID) at 100% load.
- **Harmonic performance under line imbalance conditions:** Significantly better performance. For example, under 3% line voltage imbalance performance was 28.8% better (26.3% vs. 44.3% THID) at 25% load and 6% better (12.3% vs. 18.3% THID) at 50% load.
- **Power Factor:** Similar performance for loads 50-100%. Equal performance at 25% load and 3% voltage imbalance.*

A 6-pulse drive with a Matrix AP harmonic filter has a number of additional benefits over the AFE drive: smaller equipment size, lower price, shortened lead time, and increased availability of drives and corresponding replacement parts.

*The Matrix AP harmonic filter exhibited a reduced leading power factor under light loads. While advantageous in some circumstances, a capacitor contactor option may be used to remove the filter capacitors from the circuit and eliminate this condition.

Background

The proliferation of variable frequency drives (VFDs) has brought increased attention to harmonic effects created by drives. A standard 6-pulse drive without any harmonic mitigation technology may interfere with neighboring equipment, reduce equipment life, and negatively impact the utility power quality. Under some circumstances, the total harmonic current distortion (THID) may approach the level of the fundamental current. Some drive manufacturers recommend Active Front End (AFE) drives to combat these effects. An alternative solution is the use of a traditional 6-pulse drive equipped with a passive harmonic filter; however, typical passive harmonic filters experience reduced effectiveness at loads less than 100%. With the introduction of adaptive passive technology, the Matrix AP harmonic filter maintains strong harmonic filtering performance across a wide range of loads. This paper compares the performance of a 20 HP AFE drive with the performance of a standard 30 HP 6-pulse drive equipped with a 44 amp Matrix AP harmonic filter.

6-Pulse Drive Overview

Figure 1 shows the basic block diagram of a variable frequency drive. Three phase power is applied to the converter. The converter transforms the three phase power into DC. Then the DC is applied to the inverter which transforms the DC into variable fundamental frequency pulse width modulated AC power that powers a motor.

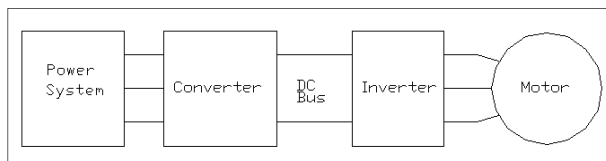

Figure 1 Basic VFD block diagram

Figure 2 shows the major components of a 6-pulse converter. The power system is typically a wye connected secondary of a transformer. There are six rectifiers that

convert three phase power to DC. Then the DC power is converted back to a variable frequency AC to be applied to the motor. The variable speed is accomplished by applying a PWM voltage to the motor through the use of IGBTs that are switching typically from 2 kHz to 12 kHz.

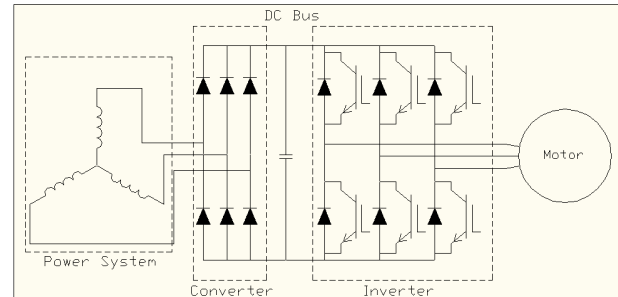

Figure 2 6-pulse power system and converter

The theoretical input current harmonics for rectifier circuits are a function of pulse number and are expressed as [1]:

$$h = (np \pm 1) \quad (1)$$

Where $n = 1, 2, 3, \dots$ and $p =$ pulse number

The theoretical lowest harmonic for a six pulse converter is the fifth.

Figure 3 shows the typical input current waveform for an unfiltered input of a 6-pulse drive. The THID can be as high as 90%.

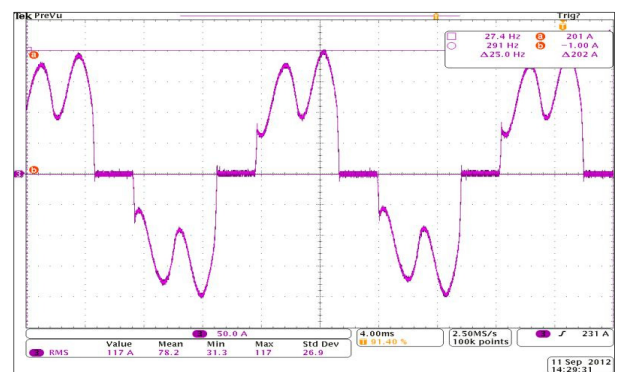

Figure 3 6-pulse unfiltered input current waveform

AFE Drive Overview

Figure 4 shows an AFE drive system. The converter is composed of six IGBTs, similar to the inverter. The six IGBTs of the converter switch to create a high frequency PWM waveform with reduced lower order harmonics. A LCL (inductor-capacitor-inductor) passive filter is typically included within the converter to reduce some of the higher order harmonics in the range from 1 kHz to 4 kHz from being applied to the power system. Figure 5 shows a 20 HP AFE drive used for performance testing.

An advantage of an AFE drive system as compared to a standard 6-pulse drive system is that some models can operate in regenerative mode. In this case, the motor is being driven by an external mechanical source and is generating power. Some AFE drive systems can take this power and return it back to the power line. For example, a drive powering an elevator would apply power to the motor while the elevator is moving in one direction. Therefore, when the elevator is going in the other direction, the elevator would drive the motor to generate power and this power could be returned to the power line. This

can offer energy savings in some applications.



Figure 5 20 HP AFE drive

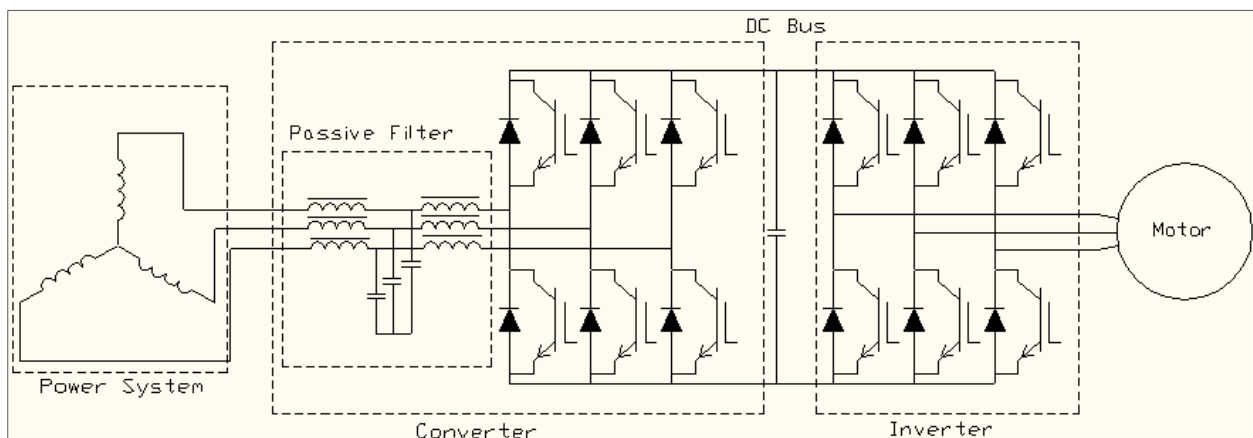

Figure 4 AFE Drive system

Matrix AP Overview

Figure 6 shows a single phase schematic representation of the use of a MTE Matrix AP filter and a 6-pulse drive. It consists of a patented [2] [3], integrated, adaptive passive inductive component (HMR – Harmonic Mitigating Reactor) and a three phase capacitance. The Matrix AP adaptive passive filter is used between a standard three phase power system and standard 6-pulse drive. Figure 7 shows the MTE Corporation Matrix AP filter part number MAPP0044D.

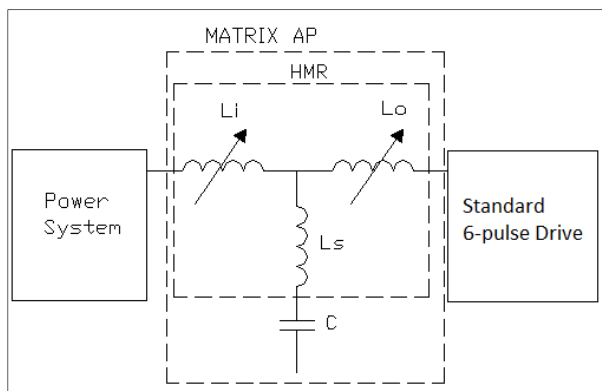

Figure 6 Matrix AP filter diagram

In Figure 6, L_s and C are tuned to near the dominant 5th harmonic generated by 6-pulse drives. L_i prevents the filter from importing the 5th harmonic from other sources and overloading the filter. The series combination of L_i , L_s and C set the tuning frequency to the power system well below the 5th harmonic. L_o reduces the voltage boost due to the capacitors. Both L_i and L_o also reduce the THID by adding wideband line filtering impedance.

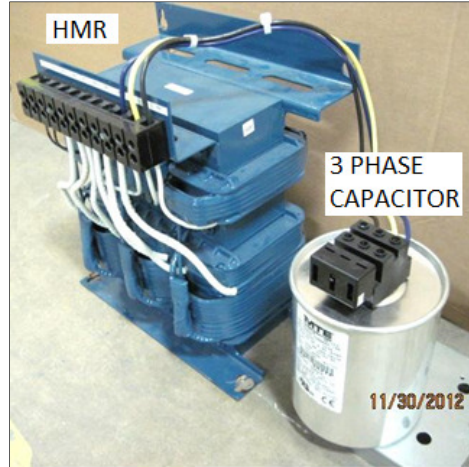

Figure 7 MTE MAPP0044D adaptive passive filter

The inductance of L_i and L_o also vary depending on load levels. At reduced load, the inductance increases to improve THID performance. The use of this adaptive passive characteristic allows the use of less capacitance and improved power factor at reduce loads without sacrificing THID performance.

Power Loss Comparison

The typical published losses of AFE drives were compared to a typical 6-pulse drive with a Matrix AP filter. Figure 8 shows a graph of power loss versus horsepower for both a typical AFE drive and a typical 6-pulse drive with a Matrix AP filter. The losses of a low horsepower AFE drive vs. a typical 6-pulse drive equipped with a Matrix AP filter is about 15%. However, the losses for a typical 1000 horsepower AFE vs. a 6-pulse drive with a Matrix AP filter drive are double.

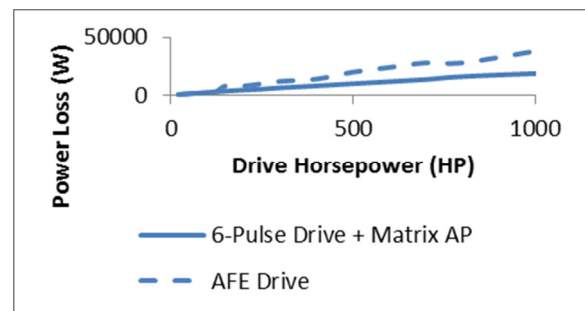

Figure 8 Power loss comparisons

Efficiency Comparison

The percent drive efficiency is calculated using the following equation, Eq. (2), since both drive topologies have near unity power factor at full load:

$$\% \text{Efficiency} = \frac{P_{out}}{P_{in}} \times 100 = \frac{(V_{in} \times I_{in} \times \sqrt{3}) - P_{drive}}{(V_{in} \times I_{in} \times \sqrt{3})} \times 100 \quad (2)$$

Figure 9 shows the efficiency of a typical AFE drive as compared to 6-pulse drives equipped with a Matrix AP filter. Most AFE drive horsepower ratings are at least 1.5% less efficient than a 6-pulse with a Matrix AP.

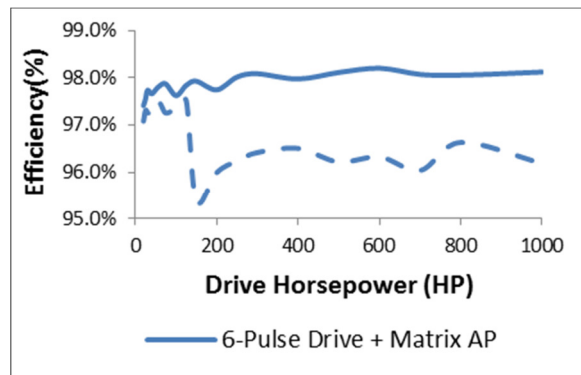

Figure 9 Efficiency Comparison

THID Comparison

The total harmonic current distortion (THID) performance of a typical 20 HP AFE drive and a 30 HP 6-pulse drive with a Matrix AP filter was compared. Figure 10 compares the actual test data between an AFE drive and a Matrix AP filter. The total harmonic voltage distortion (THVD) was about 1.2% for most of the test conditions. At full load, both performed under 5% THID, the most stringent IEEE-519 requirement for general distribution systems. The Matrix AP filter had better THID performance at reduced load. The AFE drive had about 15.6% THID at 25% load compared to 6.88% for the 6-pulse drive with a Matrix AP. For comparison, Figure 11 and Figure 12 show the current waveforms for an AFE drive and a 6-pulse drive with a Matrix AP

respectively, at 25% load. The AFE drive current waveform contains far more high frequency harmonics.

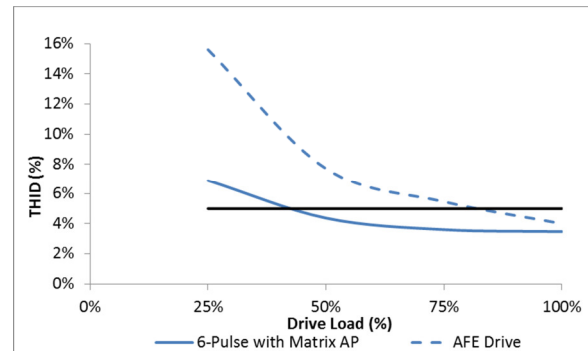

Figure 10 THID performance versus load comparison

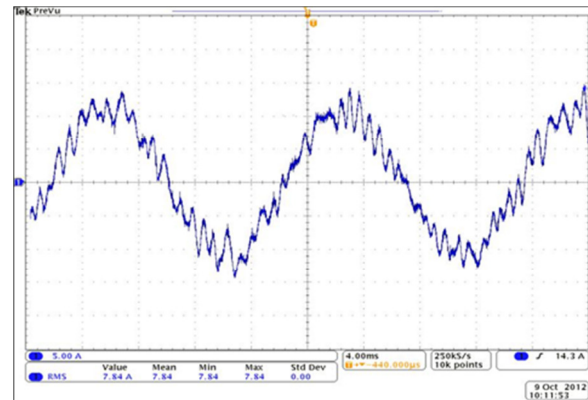

Figure 11 AFE input current waveform at 25% load

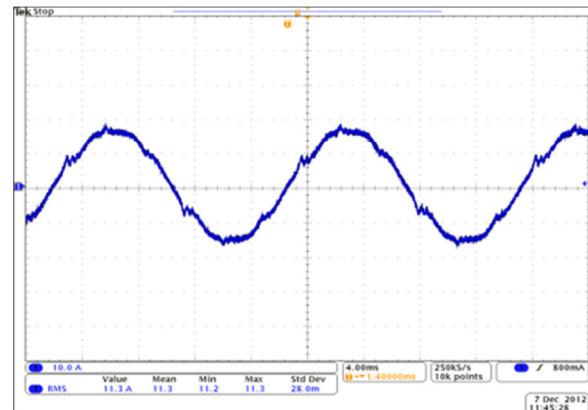

Figure 12 6-pulse drive with Matrix AP MAPP0044D input current waveform at 25% load

Figure 13 shows the harmonic mitigation performance of a standard 6-pulse drive with a Matrix AP

compared to an AFE drive with a system voltage imbalance. The system voltage distortion was about 1.3% for most test conditions. The specification for the AFE drive allowed for a maximum 3% voltage imbalance. At reduced load, the THID for the AFE drive was considerably worse than the standard 6-pulse drive with a Matrix AP filter. The AFE drive had 44.3% THID compared to 15.5% THID for the standard 6-pulse drive with a Matrix AP filter at 25% drive load and 3% voltage imbalance.

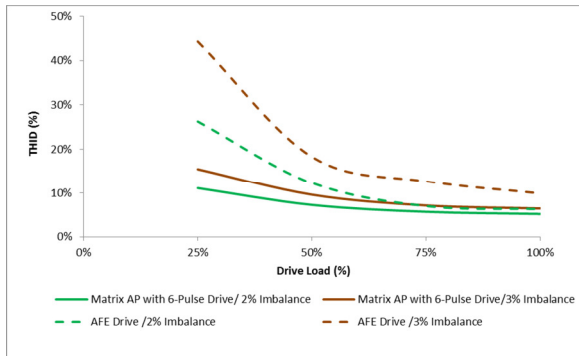

Figure 13 THID with system voltage imbalance comparison

Power Factor Comparison

The power factor performance of a typical 20 HP AFE drive and a 6-pulse drive with MAPP0044D was compared. Figure 14 shows the actual test data for comparison. Both harmonic mitigation techniques performed better than 98% power factor at loads greater than about 50% with balance voltages. The Matrix AP filter had a higher leading power factor at 25% load with balance system voltage. The Matrix AP with at 6-pulse drive and the AFE drive had similar power factor performances with a 3% voltage imbalance. The power factor for both ranged from about 0.83 to 1 over load.

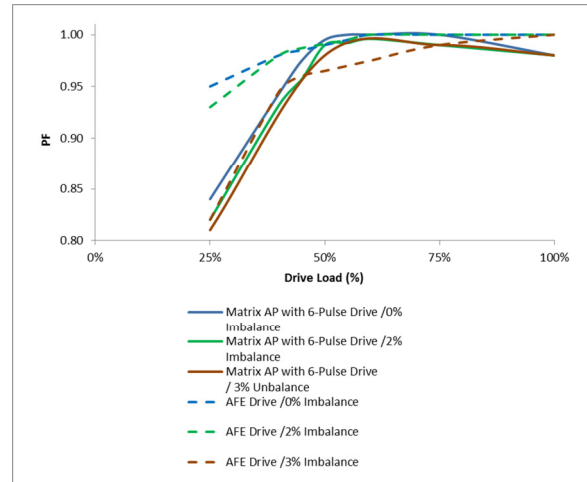

Figure 14 Power factor versus load comparison

AFE drives have been promoted as being a near unity power factor drive solution at all operating conditions. Figure 14 shows the true power factor is not unity for all operating conditions. Under some light load conditions with voltage imbalance it performs similar to a Matrix AP adaptive passive filter. Under closer scrutiny, the typical AFE product specification states, “Power factor...cos ϕ ”. The “cos ϕ ” refers to displacement power factor only. True power factor is defined as the ratio of the real power flowing to the load to the apparent power. True power factor, as the term implies, is the only true measure of how a load utilizes power. The AFE drive performs very well in terms of displacement power factor under balanced voltage conditions, near unity as the typical specification states. The equation for true power factor is [4]:

$$pf_{true} = \frac{P_{avg1}}{V_{1rms}I_{1rms}} \times \frac{1}{\sqrt{1 + (THID/100)^2}} = pf_{disp} pf_{dist} \quad (3)$$

Equation (3) assumes that the system harmonic voltage distortion is near 0. To understand why the true power factor for the AFE drive is 0.82 at 25% load with 3% system voltage imbalance equation (3) distortion power factor will be evaluated. The distortion power factor can be

evaluated using the 44.3% THID at 25% load with 3% voltage imbalance from the test data. The resulting equation is:

$$pf_{dist} = \frac{1}{\sqrt{1+(THID/100)^2}} = \frac{1}{\sqrt{1+(44.3\%/100)^2}} = 0.91. \quad (4)$$

The distortion power factor alone under lightly loaded, unbalanced system voltage condition brings the power factor down to 0.91.

The reduced power factor at reduced loads for the Matrix AP adaptive passive filter is due to the capacitance. In many power systems, this leading power factor increases the efficiency of the system because it offsets some of the loads that have lagging power factor. The power factor is adjusted closer to unity. Otherwise, standard options are available to disconnect the capacitors at light loads to increase power factor either by automatic sensing of load levels or manually by the user. Figure 15 shows MTE's Matrix AP with automatic contactor option. The load current is sensed and the capacitors are connected at 20% load and disconnected at 35% load. This hysteresis prevents chattering of the contactor.

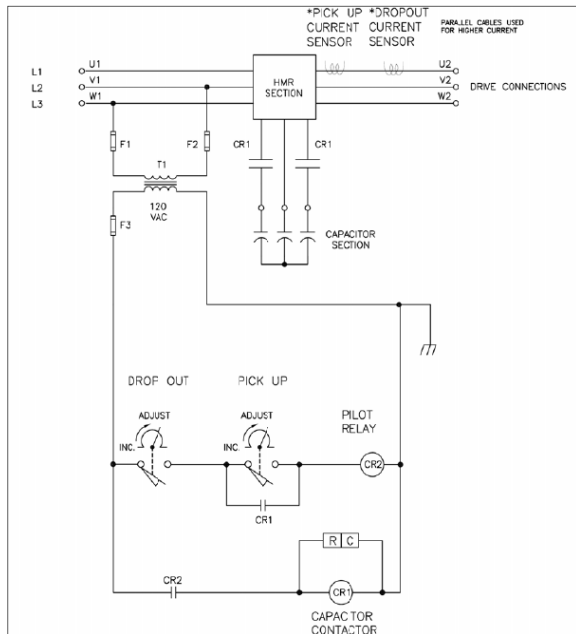

Figure 15 MTE Option -009 capacitor disconnect option schematic

Size Comparison

Figure 16 shows a side by side comparison of the 20 HP AFE drive and a 30 HP 6-pulse with a Matrix filter. Table 1 compares the overall volumes of the components of each system. The 20 HP AFE drive has double the volume of the components of a 30 HP drive with a Matrix AP filter.



Figure 16 Size comparison

Table 1 Drive system volume comparison

Component	30 HP 6-Pulse Drive and Matrix AP	20 HP AFE Drive
Drive (in ³)	1,255	4,669
HMR (in ³)	982	NA
Capacitor (in ³)	114	NA
Total Volume (in ³)	2,351	4,669

Conclusion

The 6-pulse drive with Matrix AP harmonic filter outperformed the AFE drive in the following important areas:

- **Harmonic performance under balanced line conditions:** 2-9% better THID performance 25-75% loads and similar performance (about 4% THID) at 100% load.
- **Harmonic performance under line imbalance conditions:** Significantly better performance. For example, under 3% line voltage imbalances performance was 28.8% better (26.3% vs. 44.3% THID) at 25% load, and 6% better (12.3% vs. 18.3% THID) at 50% load.
- **Power Factor:** Similar performance for loads 50-100%. Equal performance at 25% load and 3% voltage imbalance.*

A 6-pulse drive with a Matrix AP harmonic filter has a number of additional benefits over the AFE drive: smaller equipment size, lower price, shortened lead time, and increased availability of drives and corresponding replacement parts.

*The Matrix AP harmonic filter exhibited a reduced leading power factor under light loads. While advantageous in some circumstances, a capacitor contactor option may be used to remove the filter capacitors from the circuit and eliminate this condition.

References

- [1] Hink, Karl M. "18-Pulse Drives and Voltage Unbalance." MTE Corporation
- [2] Shudarek, Todd A. "Multiple Three-phase Inductor with a Common Core." US Patent 7,142,081. 28 Nov 2006.
- [3] Shudarek, Todd A., Walcott, Wayne and Ruther, Wesley. "Harmonic Mitigation Devices and Applications Thereof." WIPO Patent Application WO/2012/103152.
- [4] Grady, Mack W., Gilleskie, Robert J. "Harmonics and How they Relate to Power Factor." EPRI Power Quality Issues & Opportunities (PQA '93). San Diego. CA, November 1993.