

MTE Corporation

MTE –Series RL Line/ load Reactors

USER MANUAL

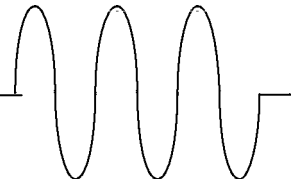

PART NO. INSTR -011

REL. 060227

© 2006 MTE Corporation

Important User Information

NOTICE

MTE Series RL Line/Load Reactors are components designed to improve the reliability of adjustable frequency drives, DC drives and a wide variety of other types of power electronic equipment. In addition they provide limited input line current harmonic mitigation and aid in long lead protection for inverter fed motors. Note: (See MTE harmonic filters and motor protection products for guaranteed results.) MTE reactors are available in a large number of current ratings and a variety of inductance values. The suitability of a line/load reactor for a specific application must therefore be ultimately determined by the customer. In no event will MTE Corporation assume responsibility or liability for any direct or consequential damages resulting from the use or application of reactors. Nor will MTE Corporation assume patent liability with respect to the use of information, circuits or equipment described in this instruction manual.

This manual includes recently redesigned performance enhanced reactors. These reactors are physically smaller and weigh less than the reactors they replace. Enhanced reactors have base mounting brackets with additional slotted holes to accommodate past mounting hole centers. You may use your existing drill pattern or choose the new layout. The tables contained in this manual reflect historical mounting dimensions for previous reactors.

This document supports computer searches and is best viewed with Adobe Acrobat™ PDF viewer (6 or 7). Click links are incorporated throughout the document to speedup document navigation.

MTE AC Line / Load Reactors

User Manual

Table of Contents

IMPORTANT USER INFORMATION	2
TABLE OF CONTENTS	3
IMPORTANT SAFETY INFORMATION	4
INTRODUCTION	5
MODEL NUMBER CODES	6
SPARE PARTS	7
LUG OPTION DETAILS:	8
PRODUCT SPECIFICATIONS	10
DE-RATING CURVES	13
DIMENSION REFERENCE	14
MOUNTING COMPATIBILITY	15
MECHANICAL DETAILS OPEN REACTORS	16
NEMA1 MECHANICAL DATA	18
RECOMMENDED CONDUIT ENTRY FOR FLOOR MOUNTED	20
ENCLOSURE DIMINSIONS	21
TECHNICAL DATA	25
INSTALLATION INSTRUCTIONS.....	27
POWER WIRING CONNECTION	28
TYPICAL CONNECTION DIAGRAMS	29
SEQUENCE OF OPERATION	30
STARTUP	31

MTE AC Line / Load Reactors

User Manual

IMPORTANT SAFETY INFORMATION

WARNING

ONLY A QUALIFIED ELECTRICIAN CAN CARRY OUT THE ELECTRICAL INSTALLATION OF LINE/LOAD REACTORS

WARNING

High voltage is used in the operation of line/load reactors. Use Extreme caution to avoid contact with high voltage when operating, installing or repairing equipment containing line/load reactors

INJURY OR DEATH MAY RESULT IF SAFETY PRECAUTIONS ARE NOT OBSERVED.

Line/load reactors are used in conjunction with inverters, or other electrical equipment that may feedback lethal voltages. Follow the safety instructions in the equipment used with the reactor in addition to the safety instruction in this manual.

WARNING

The opening of the branch circuit protective device may be an indication that a fault current has been interrupted. To reduce the risk of fire or electrical shock, line/load reactors should be examined and replaced if damaged.

WARNING

An upstream disconnect/protection device must be used as required by the National Electrical Code (NEC).

WARNING

Even if the upstream disconnect/protection device is open, a drive or inverter down stream of the line/load reactor may feed back high voltage to the reactor. The inverter or drive safety instructions must be followed.

INJURY OR DEATH MAY RESULT IF THE DRIVE SAFETY PRECAUTIONS ARE NOT OBSERVED.

WARNING

The frame of line/load reactors must be grounded at least at one of the reactor's mounting holes.

WARNING

Only spare parts obtained from MTE Corporation or an authorized MTE distributor can be used

MTE AC Line / Load Reactors

User Manual

INTRODUCTION

This manual was specifically developed to assist in the installation, interconnection and operation of MTE Corporation Series RL Line/Load Reactors

This manual is intended for use by personnel experienced in the operation and maintenance of electronic drives, inverters and similar types of power electronic equipment. Because of the high voltages required by the equipment connected to line/load reactors and the potential dangers presented by rotating machinery, it is essential that all personnel involved in the operation and maintenance of line/load reactors know and practice the necessary safety precautions for this type of equipment. Personnel should read and understand the instructions contained in this manual before installing, operating or servicing line/load reactors and the drive to which the reactor is connected.

Upon Receipt of a Reactor:

MTE Line/load Reactors have been subjected to demanding factory tests before shipment. Carefully inspect the shipping container for damage that may have occurred in transit. Then unpack the filter and carefully inspect for any signs of damage. Save the shipping container for future transport of the reactor.

In the event of damage, please contact and file a claim with the freight carrier involved immediately.

If the equipment is not going to be put into service upon receipt, cover and store the reactor in a clean, dry location. After storage, ensure that the equipment is dry and that no condensation has accumulated on the reactor before applying power.

Repair/Exchange Procedure

MTE Corporation requires a Returned Material Authorization Number before it can accept any reactors that qualify for return or repair. If problems or questions arise during installation, setup, or operation of the filter, please call us for assistance at:

Phone: 1-262-253-8200

FAX: 1-262-253-8222

MTE AC Line / Load Reactors

User Manual

MODEL NUMBER CODES

RL		MOV option	Fundamental Current Amps				Style	Z No.	Option suffix
			1000	100	10	1			
none	blank								
208 Volts	A					↑	1	↑	
240 Volts	C					Open Frame	0	↑	
380 - 415 volts	E					NEMA 1	1	↑	
480 Volts	G					OVERSIZE NEMA 1	2	↑	
600 Volts	J					NEMA 3R	3	↑	
<i>Custom design</i>		X						↑	

Substitute Box Lug for terminal block **B**

Substitute Tab terminal w/clearance hole **B1**

Substitute flexible leads (18 inches typical) **B5**

Substitute next larger Box Lug **B6**

Substitute 35 amp terminal block for smaller terminal block **B7**

Rotate terminal block 90 degrees **B8**

Add 3-point control circuit terminal block to 45 amps **B9**

Add 3-point control circuit terminal block to 750 amps **B11**

Sub. accessory wiring t/b **B10**

Substitute front facing tab (flag) terminal **B14**

Substitute next larger terminal block 12 to 35 amps **B18**

Add 3-NC over temp switches w/ 6 point terminal block **T**

Add 1 thermocouple per coil (customer supplied) **T1**

Add 3-NC over temp switches with leads **T2**

Add 1-NC over temp switch w/ 2 point terminal block **T5**

Add 3-NO over temp switches w/6 point terminal block **T6**

Add thermocouple to center coil only (customer supplied)... **T7**

MTE AC Line / Load Reactors

User Manual

Spare Parts

For standard type "RL" AC Line / Load Reactors

<u>Description</u>	<u>Part No.</u>
To adds "SLU 225" box lugs on B14	Lug Kit 001
To adds "XT 500" box lugs on B14	Lug Kit 002

Terminal Blocks

<u>Description</u>	<u>Part No.</u>
For RL-00101 thru RL-00804	36-822-049
For RL-01201 thru RL-03502	36-825-004
For RL-03503 thru RL-04503	TERMBLK-013

MTE AC Line / Load Reactors

User Manual

LUG OPTION DETAILS:

"B1" Terminal Modification

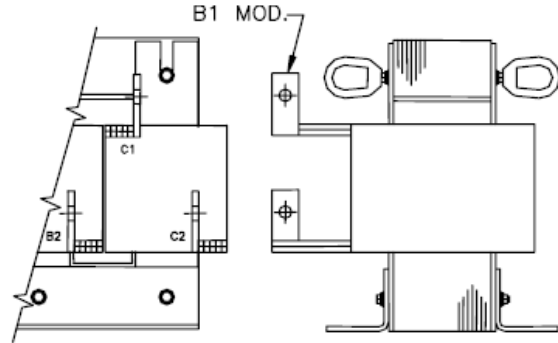

"B14" Terminal Modification

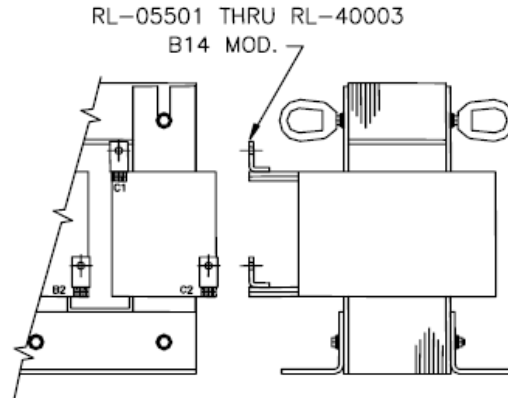

RL-00201 THRU RL-04503

"B8" Terminal Modification

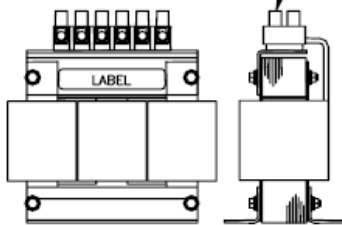

"B8" Terminal Modification

"SLU" Lug Option

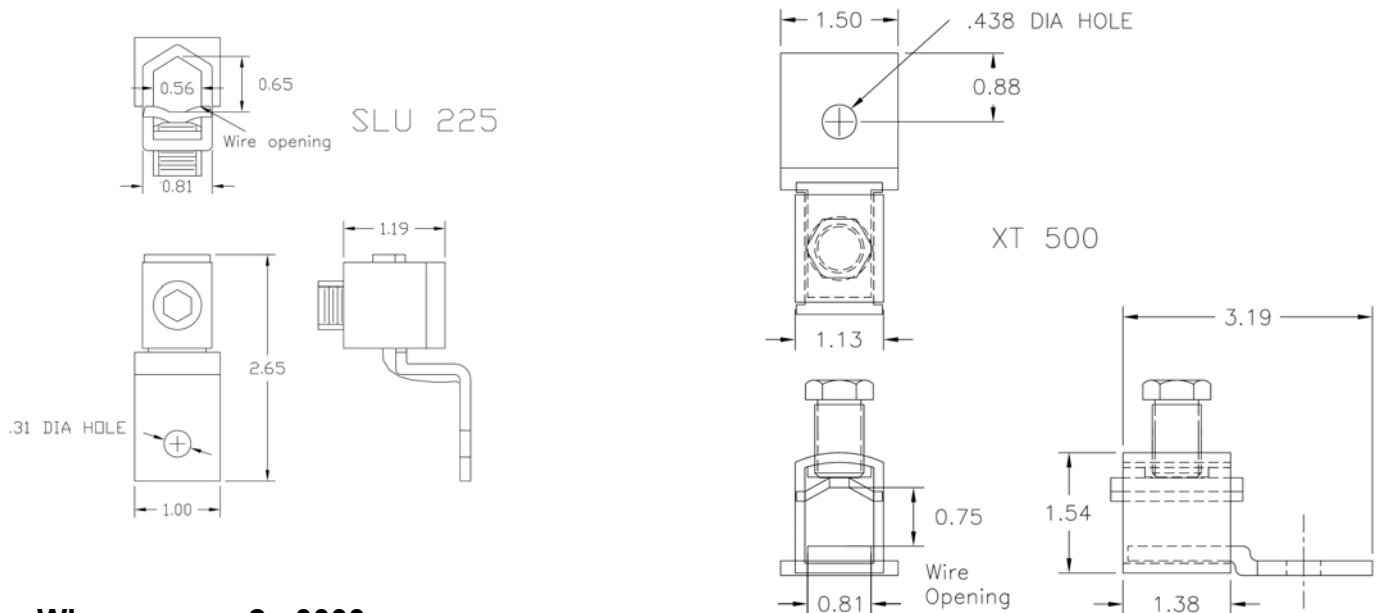

Wire range: 2 - 0000

Wire range: 00 - 500 mcm

MTE AC Line / Load Reactors

User Manual

SLU Lug Options cont.

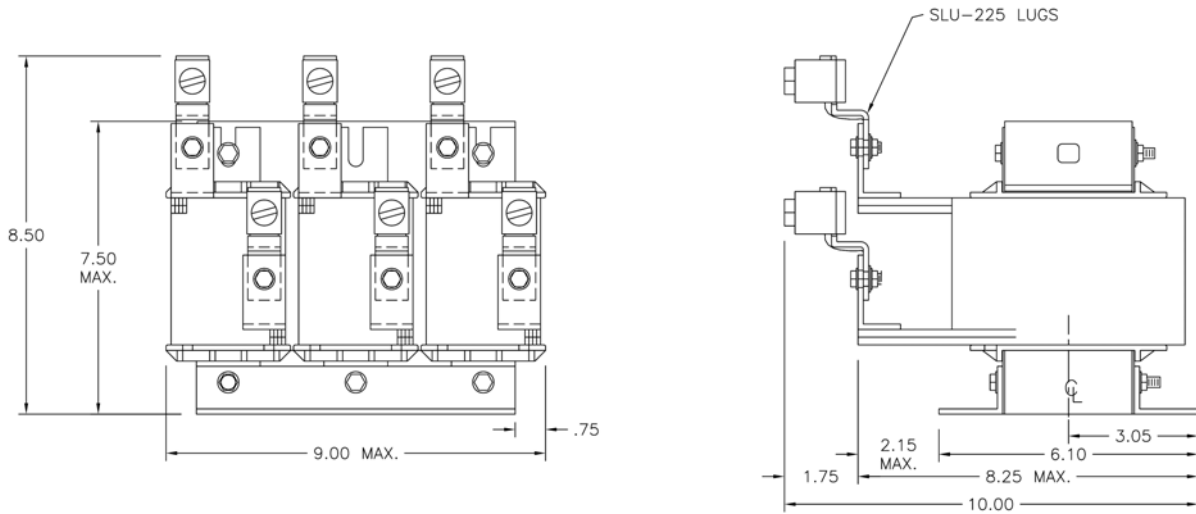

SLU 225 shown on 200 amp Reactor

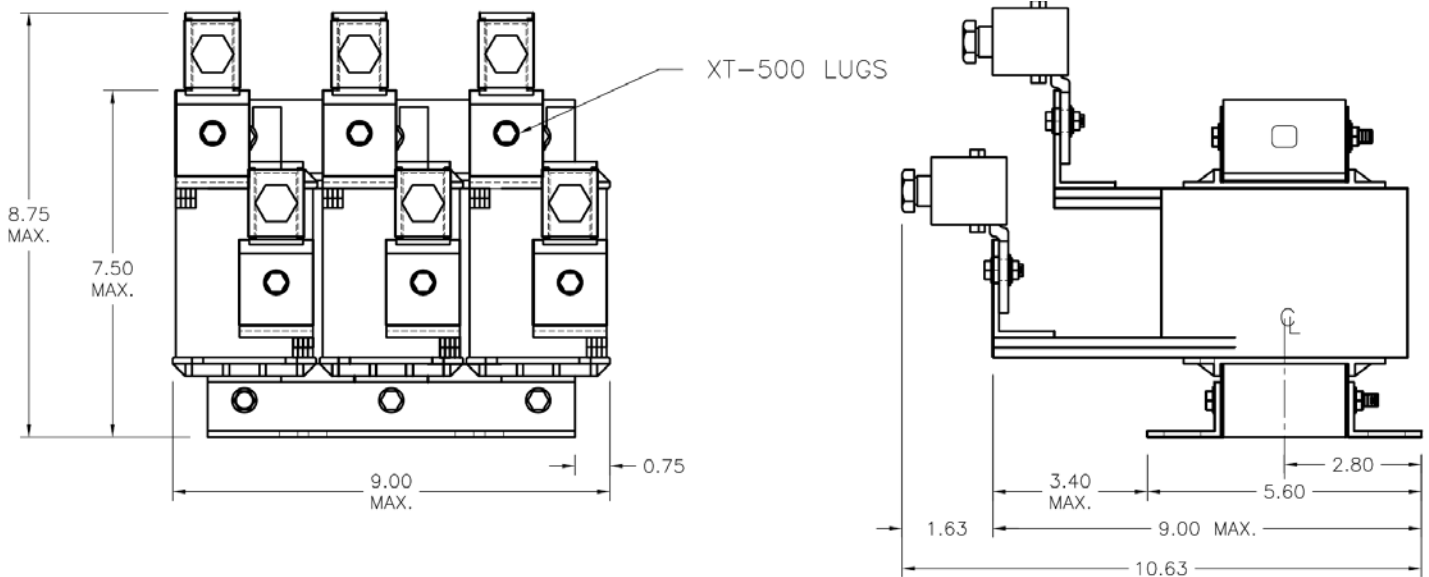

XT 500 shown on 250 amp Reactor

MTE AC Line / Load Reactors

User Manual

PRODUCT SPECIFICATIONS

Standard impedance values	1-1/2%, 2, 3%, 4%, 5% available
Impedance basis	Reactor fundamental current rating
Service Factor (Continuous)	
Reactors rated 1 to 750 Amps	150% of fundamental rating
Reactors rated above 750 Amps	125% of fundamental rating minimum
rating	Note: Select reactor based on <u>fundamental current</u>
Overload Rating	200% of fundamental for 30 minutes 300% of fundamental for 1 minute
Maximum system voltage	600 Volts (units with terminal blocks) 690 Volts (units with box lugs or tab terminals)
Maximum switching frequency	20 KHz
Insulation system	Class N (200° C)
Temperature rise	
Open or enclosed reactors	135° C (average)
Ambient temperature	
Open or enclosed reactors	45° C (maximum)
Altitude (maximum)	1000 meters
Fundamental frequency	
Line or Load	50/60 Hz
Approvals:	CE, UL-508, CSA C22.2
Inductance curve (typical)	100% at 100% current 100% at 150% current 50% at 350% current (minimum)
Inductance tolerance	+/- 10%
Impregnation:	High Bond Strength "Solvent less" Epoxy, 200° C UL94HB recognized
Dielectric Strength	3000 volts rms (4243 volts peak)
dv/dt Protection motors)	Meets NEMA MG-1, part 31 (same as inverter duty
Protection: meet IP20	Open reactors with terminal blocks through 45 amps

MTE AC Line / Load Reactors

User Manual

PRODUCT SPECIFICATIONS (cont'd)

AGENCY APPROVALS:

UL-508, File E180243 Component Listed (1 amp – 2400 amps)
UL-508, File E180243 **UL Listed** NEMA 1 units (1 amp – 2400 amps)
CSA C22.2, File LR29753-13 CSA Certified (1 amp – 2400 amps)
Class N, 200° C, File E66214, Type 200-18, UL Recognized Insulation System
CE Marked

MATERIAL:

Core Steel: Electrical grade silicon steel
Windings: High dielectric withstand solid copper conductor (220° C)
Enclosures: Sheet steel in accordance with UL and CSA requirements. Painted ANSI-61 Grey
Brackets: ASTM structural steel or structural aluminum
Terminations: 1 – 45 amps - Finger safe terminal block
55 - 160 amps - Solid copper box lugs (Tab terminals are optional)
200 + amps - Copper tab terminals
Sheet Insulation: DuPont Nomex 410 (220° C)
Epoxy: Ripley Resin Type 468-2 (220° C)

CONSTRUCTION:

CORE: Electrical grade silicon steel magnetic laminations.

WINDINGS: Meet 3000 volts rms dielectric strength (coil – to coil and coil- to – core).

ASSEMBLY: Windings are assembled onto EI laminations, secured in place and epoxy impregnated for minimum noise and maximum structural rigidity.

COLOR: Royal Blue

TESTING: Electronic Turns Count (Zero Tolerance)
Inductance
Hi-Pot 3000 Volts rms (5656 volts peak)
Mechanical Inspection

MTE AC Line / Load Reactors

User Manual

PRODUCT SPECIFICATIONS (cont'd)

AUDIBLE NOISE: Guard-AC Line/Load Reactors offer low noise operation. Core and coil construction, flux density control, harmonic compensation as well as our epoxy impregnation process assure minimal audible noise radiation. Although our reactors are typically “quiet”, waveforms vary by drive type and application and therefore reactor audible noise may vary by application. Noise levels may be affected by type of motor and motor conductor as well as motor conductor length. Typical audible noise levels for units selected from our catalog by HP rating are:

2 thru 12 amps	55 dBA
18 thru 100 amps	65 dBA
130 thru 400 amps	70 dBA
500 thru 1200 amps	75 dBA

Service Factor: Guard-AC reactors are compensated for the additional currents and high frequencies caused by the presence of harmonics. The reactor fundamental current rating indicates the typical full load motor current and is also the basis of impedance rating. Standard reactors rated 1 amps thru 750 amps offer a full 1.5 service factor rating which allows them to carry overload current up to 150% of their fundamental rating when applied as an input line reactor. Since the nameplate ratings of motor drives (ASD) varies widely by manufacturer, this helps to assure that the reactor maximum current rating is compatible with the nameplate current rating on the ASD. The service factor rating compensates for ASD manufacturer variances in motor drive current ratings and for harmonic currents. Nominal inductance is assured all the way up to the service factor current rating.

PWM / IGBT PROTECTION: Guard-AC reactors are protected against the high peak voltage and fast rise time voltage pulses associated with PWM waveforms. The dielectric strength is 4000 volts rms and Guard-AC reactors meet the ratings of an inverter duty motor (NEMA MG-1, part 31). For convenience, they can be located either at the motor or at the drive.

HARMONIC ATTENUATION: Our unique harmonic compensation assures maximum circuit inductance in the presence of complex waveforms and can be relied upon to minimize input total harmonic current distortion (THID). Additionally it offers superior absorption of transient voltage spikes. Our standard reactors will typically reduce 6-pulse rectifier input current harmonics to the following levels at full load operating conditions:

3% reactor alone	45% or less THID
5% reactor alone	35% or less THID
3% AC reactor + 3% DC link choke	33% or less THID
5% AC reactor + 3% DC link choke	28% or less THID

(DC link choke inductance is equivalent ac impedance).

MTE AC Line / Load Reactors

User Manual

DE-RATING CURVES

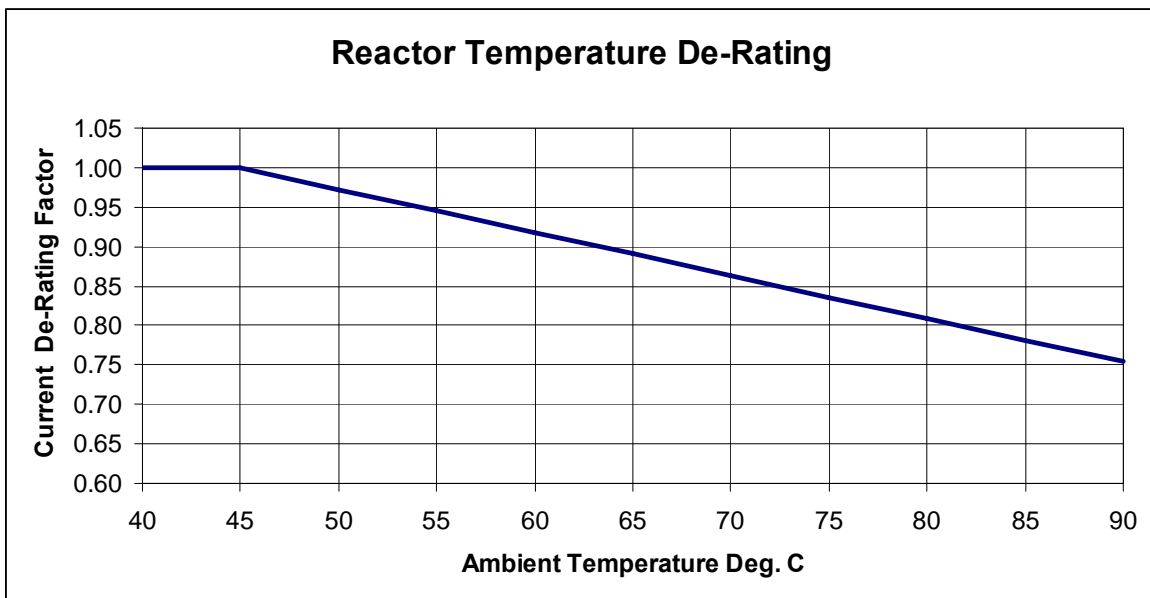
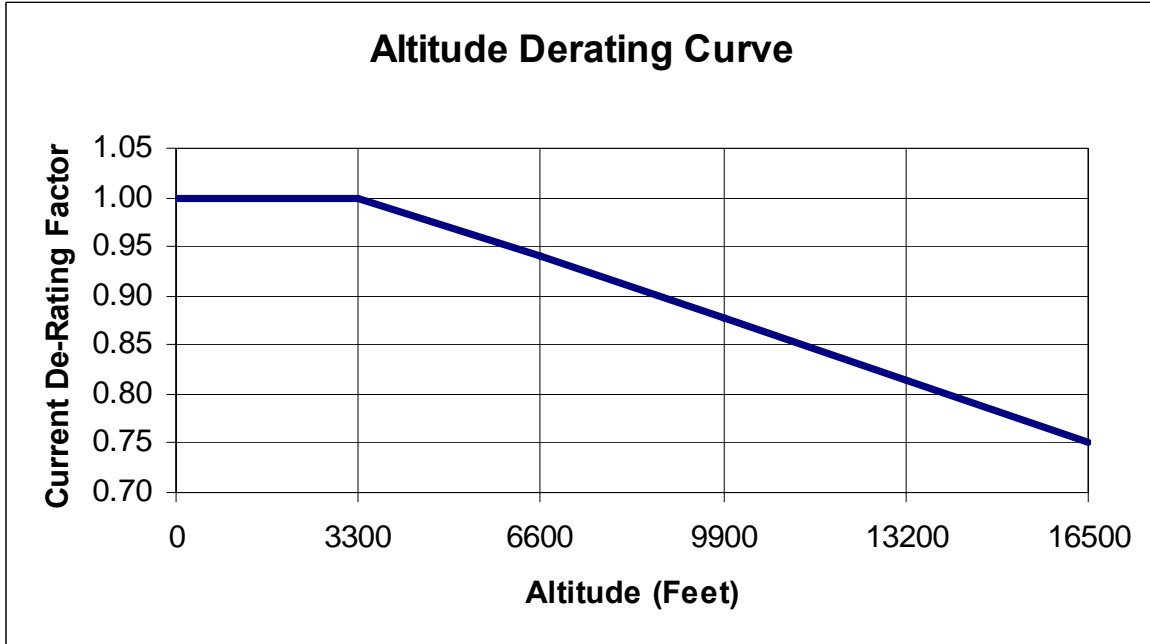

MTE AC Line / Load Reactors

User Manual

Dimension Reference

Open Type

Visit the MTE web for reactor detail drawings www.mtecorp.com

Dimensions A, B, C show overall spacing allowances
Use dimension D and E for mounting pattern

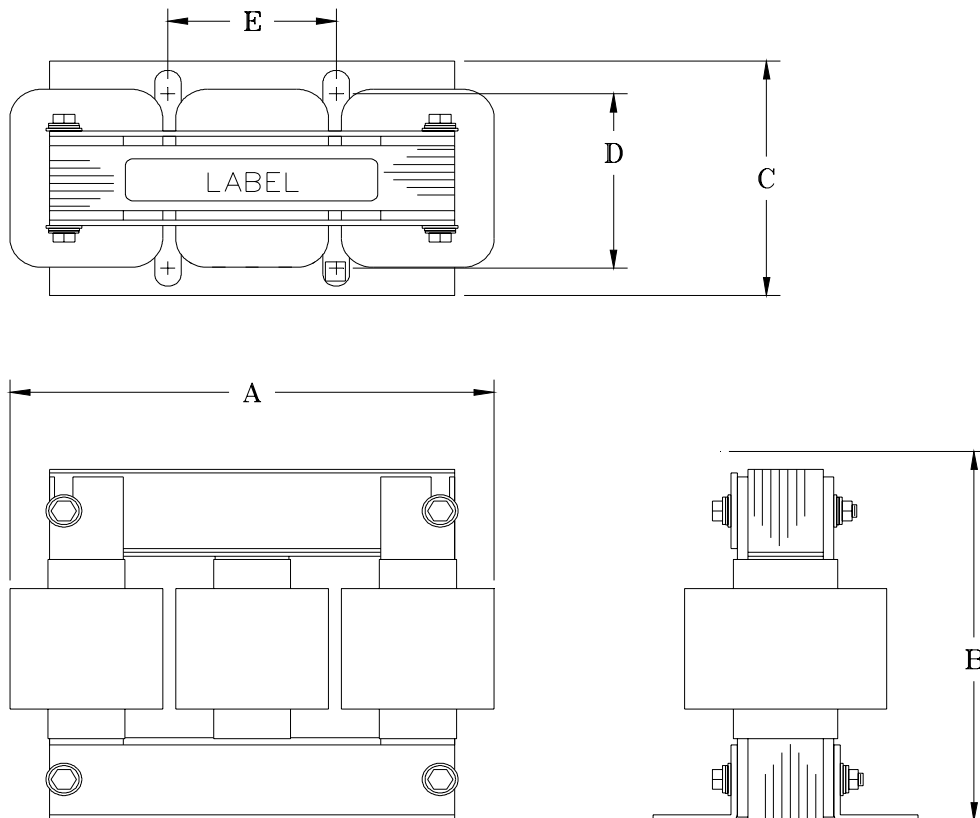

See "[Mechanical Details Table](#)" for dimensional data

MTE AC Line / Load Reactors

User Manual

Mounting Compatibility

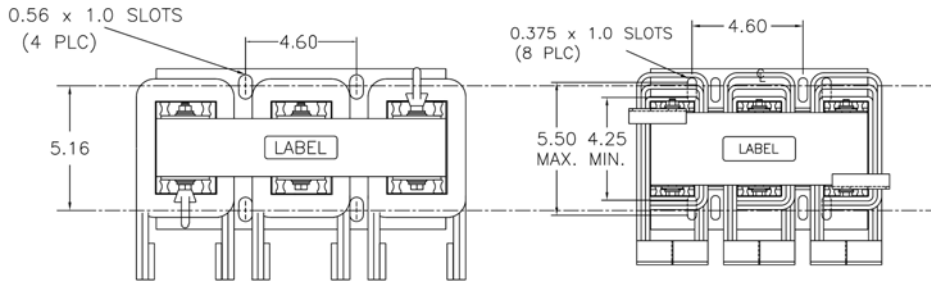

Previous Reactor Mounting

Performance Enhanced Reactor Mounting

RL-25002B14 SHOWN

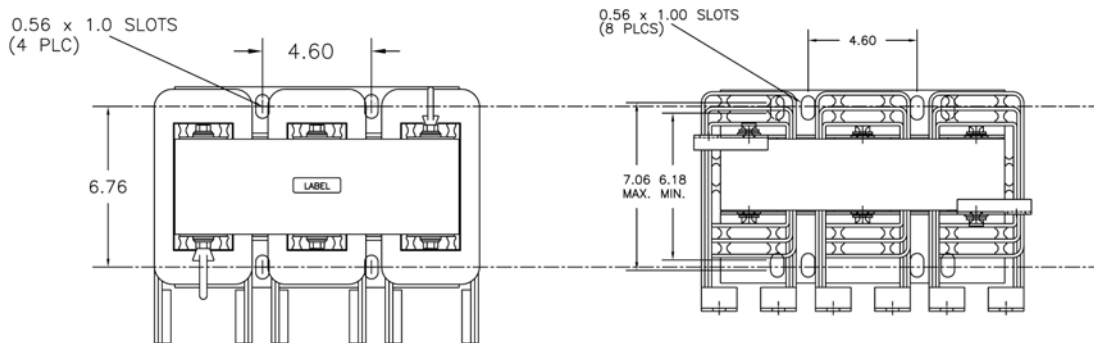

Previous Reactor Mounting

Performance Enhanced Reactor Mounting

RL-40002 SHOWN

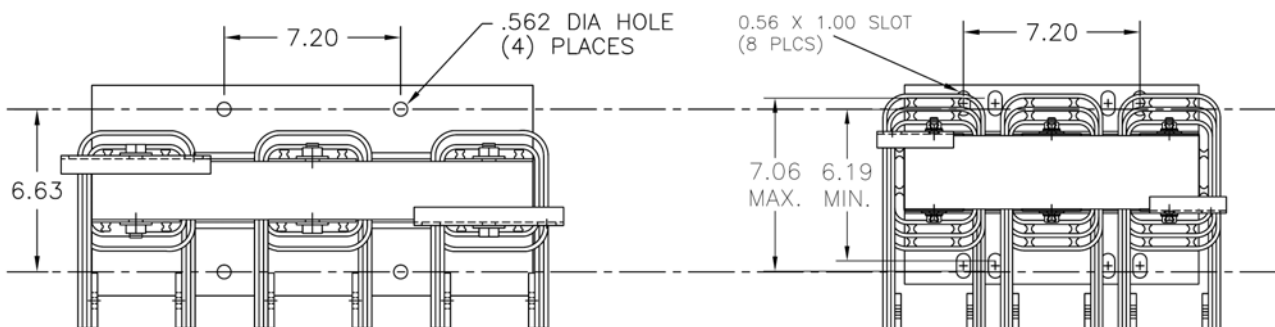

Previous Reactor Mounting

Performance Enhanced Reactor Mounting

RL-75001 SHOWN

MTE AC Line / Load Reactors

User Manual

Mechanical Details Open Reactors

MTE Cat. No.	A		B		C		D		E		Weight	Mass
	Inches	mm	Inches	mm	Inches	mm	Inches	mm	Inches	mm	Lbs	Kg
RL-00101	3.8	97	3.5	89	1.2	30	2.40	61.0	1.44	36.6	4	1.8
RL-00102	3.8	97	3.5	89	1.2	30	1.98	50.3	1.44	36.6	4	1.8
RL-00103	3.8	97	3.5	89	1.2	30	1.98	50.3	1.44	36.6	3	1.4
RL-00104	3.8	97	3.5	89	1.2	30	1.98	50.3	1.44	36.6	3	1.4
RL-00201	4.4	112	4.1	104	2.8	71	1.98	50.3	1.44	36.6	4	1.8
RL-00202	4.4	112	4.1	104	2.8	71	1.98	50.3	1.44	36.6	4	1.8
RL-00203	4.4	112	4.1	104	2.8	71	1.98	50.3	1.44	36.6	4	1.8
RL-00204	4.4	112	4.1	104	2.5	64	1.73	43.9	1.44	36.6	3	1.4
RL-00401	4.4	112	4.1	104	2.8	71	1.98	50.3	1.44	36.6	4	1.8
RL-00402	4.4	112	4.1	104	2.8	71	1.98	50.3	1.44	36.6	4	1.8
RL-00403	4.4	112	4.1	104	3.4	86	2.35	59.7	1.44	36.6	5	2.3
RL-00404	4.4	112	4.1	104	3.4	86	2.60	66.0	1.44	36.6	6	2.7
RL-00801	6.0	152	4.8	122	3.0	76	2.10	53.3	2.00	50.8	7	3.2
RL-00802	6.0	152	4.8	122	3.0	76	2.10	53.3	2.00	50.8	8	3.6
RL-00803	6.0	152	4.8	122	3.4	86	2.62	66.5	2.00	50.8	11	5.0
RL-00804	6.0	152	4.8	122	3.4	86	2.48	63.0	2.00	50.8	13	5.9
RL-01201	6.0	152	5.0	127	3.3	84	2.10	53.3	2.00	50.8	9	4.1
RL-01202	6.0	152	5.0	127	3.3	84	2.10	53.3	2.00	50.8	10	4.5
RL-01203	6.0	152	5.0	127	3.9	99	2.75	69.9	2.00	50.8	18	8.2
RL-01801	6.0	152	5.3	135	3.2	81	2.10	53.3	2.00	50.8	9	4.1
RL-01802	6.0	152	5.3	135	3.5	89	2.48	63.0	2.00	50.8	12	5.4
RL-01803	8.1	206	6.1	155	4.0	102	2.60	66.0	3.00	76.2	16	7.3
RL-02501	7.2	183	5.8	147	3.5	89	2.35	59.7	3.00	76.2	11	5.0
RL-02502	7.2	183	5.8	147	3.5	89	2.35	59.7	3.00	76.2	14	6.3
RL-02503	7.2	183	5.8	147	4.3	109	3.10	78.7	3.00	76.2	20	9.1
RL-03501	7.2	183	5.8	147	4.0	102	2.60	66.0	3.00	76.2	14	6.3
RL-03502	7.2	183	5.8	147	4.0	102	2.75	69.9	3.00	76.2	16	7.3
RL-03503	9.0	229	7.4	188	4.7	119	3.16	80.3	3.00	76.2	30	14
RL-04501	9.0	229	7.4	188	4.7	119	3.16	80.3	3.00	76.2	23	10
RL-04502	9.0	229	7.4	188	4.7	119	3.16	80.3	3.00	76.2	28	13
RL-04503	9.0	229	7.3	185	5.3	135	3.66	93.0	3.00	76.2	39	18
RL-05501	9.0	229	7.3	185	5.3	135	3.16	80.3	3.00	76.2	24	11
RL-05502	9.0	229	7.0	178	5.3	135	3.16	80.3	3.00	76.2	27	12
RL-05503	9.0	229	7.0	178	6.0	152	3.91	99.3	3.00	76.2	41	19
RL-08001	9.0	229	7.2	183	6.3	160	3.47	88.1	3.63	92.2	25	11
RL-08002	9.0	229	7.2	183	6.5	165	3.47	88.1	3.63	92.2	33	15
RL-08003	10.8	274	8.5	216	6.8	173	4.16	105.7	3.63	92.2	61	28
RL-10001	9.0	229	7.3	185	6.5	165	3.30	83.8	3.63	92.2	29	13
RL-10002	9.0	229	7.3	185	6.8	173	3.66	93.0	3.63	92.2	37	17
RL-10003	10.8	274	8.3	210	6.2	156	4.16	105.7	3.63	92.2	74	34
RL-13001	9.0	229	7.0	178	4.7	118	3.16	80.3	3.00	76.2	29	13
RL-13002	9.0	229	7.2	183	6.8	173	3.66	93.0	3.63	92.2	43	20
RL-13003	11.0	279	8.5	216	6.2	156	4.16	105.7	3.63	92.2	64	29
RL-16001	9.0	229	7.2	183	6.8	173	3.16	80.3	3.63	92.2	41	19
RL-16002	10.8	274	8.3	211	6.0	152	3.47	88.1	3.63	92.2	50	23

See www.mtecorp.com "Line load Reactors" for current dimensions and CAD details

MTE AC Line / Load Reactors

User Manual

Mechanical Data Open Type Cont.

MTE	A		B		C		D		E		Weight	Mass
Cat. No.	Inches	mm	Inches	mm	Inches	mm	Inches	mm	Inches	mm	Lbs	Kg
RL-20001B14	9.0	229	7.5	191	7.3	185	4.16	105.7	3.63	92.2	38	17
RL-20002B14	9.0	229	7.5	191	8.3	211	4.41	112.0	3.63	92.2	54	24
RL-20003B14	10.8	274	8.3	211	10.0	254	5.91	150.1	3.63	92.2	100	45
RL-25001B14	9.0	229	7.5	191	9.0	229	4.19	106.4	3.63	92.2	47	21
RL-25002B14	10.8	274	8.5	216	9.0	229	5.16	131.1	4.60	116.8	80	36
RL-25003B14	14.4	366	11.2	284	10.3	262	5.82	147.8	4.60	116.8	125	57
RL-32001B14	10.8	274	9.0	229	8.3	211	5.16	131.1	4.60	116.8	80	36
RL-32002B14	10.8	274	9.0	229	10.0	254	5.88	149.4	4.60	116.8	102	46
RL-32003B14	14.4	366	11.3	286	10.5	267	7.13	181.1	4.60	116.8	160	73
RL-40001B14	10.8	274	10.0	254	10.0	254	5.16	131.1	4.60	116.8	84	38
RL-40002B14	15.0	381	11.3	286	11.5	292	6.76	171.7	4.60	116.8	118	54
RL-40003B14	14.4	366	11.3	286	12.5	318	7.26	184.4	4.60	116.8	149	68
RL-50001	10.8	274	9.0	229	10.5	267	5.50	139.7	4.60	116.8	93	42
RL-50002	14.4	366	11.5	292	11.5	292	6.76	171.7	4.60	116.8	118	54
RL-50003	14.4	366	11.5	292	13.3	338	9.76	247.9	4.60	116.8	210	95
RL-60001	14.4	366	11.5	292	10.0	254	5.26	133.6	4.60	116.8	120	54
RL-60002	14.4	366	11.3	286	12.0	305	8.00	203.2	4.60	116.8	175	79
RL-60003	14.4	366	11.3	286	15.0	381	9.26	235.2	4.60	116.8	270	122
RL-75001	14.4	366	11.5	292	11.0	279	6.63	168.4	7.20	182.9	140	63
RL-75002	14.4	366	11.5	292	12.5	318	8.01	203.5	7.20	182.9	190	86
RL-75003	14.4	366	14.5	368	14.0	356	9.26	235.2	7.20	182.9	265	120
RL-85001	20.3	514	16.8	425	13.0	330	7.60	193.0	7.20	182.9	285	129
RL-85002	22.0	559	16.8	425	13.0	330	8.00	203.2	7.20	182.9	370	168
RL-85003	22.5	572	16.8	427	18.0	457	9.00	228.6	7.20	182.9	452	205
RL-100001	21.6	549	16.8	425	11.0	279	7.26	184.4	7.20	182.9	320	145
RL-100002	20.3	514	16.8	425	13.0	330	8.50	215.9	7.20	182.9	408	185
RL-100003	20.3	514	16.8	425	15.0	381	10.76	273.3	7.20	182.9	589	267
RL-120001	22.5	572	17.0	432	13.0	330	11.00	279.4	7.20	182.9	425	193
RL-120002	21.5	546	17.0	432	20.0	508	10.76	273.3	7.20	182.9	440	200
RL-120003	16.8	427	17.0	432	18.5	470	11.00	279.4	7.20	182.9	560	254
RL-140001	22.0	559	17.0	432	22.0	559	11.00	279.4	7.20	182.9	500	227
RL-140002	19.0	483	17.0	432	19.0	483	11.00	279.4	7.20	182.9	525	238
RL-140003	22.0	559	17.0	432	22.0	559	11.00	279.4	7.20	182.9	850	385
RL-150001	22.0	559	17.0	432	22.0	559	11.00	279.4	7.20	182.9	635	288
RL-150002	16.9	429	17.0	432	16.0	406	11.00	279.4	7.20	182.9	675	306
RL-150003	22.0	559	17.0	432	22.0	559	11.00	279.4	7.20	182.9	900	408
RL-180001	22.0	559	17.0	432	22.0	559	11.00	279.4	7.20	182.9	700	317
RL-180002	22.0	559	17.0	432	22.0	559	10.38	263.7	7.20	182.9	860	390
RL-180003	22.0	559	17.0	432	22.0	559	11.00	279.4	7.20	182.9	1090	494
RL-210001	24.0	610	18.0	457	24.0	610	11.00	279.4	7.20	182.9	800	363
RL-210002	24.0	610	18.0	457	24.0	610	11.00	279.4	7.20	182.9	970	440

See www.mtecorp.com "Line load Reactors" for current dimensions and CAD details

MTE AC Line / Load Reactors

User Manual

NEMA1 Mechanical Data

Catalog Number	Cabinet Number	Weight	
		Lbs	Mass Kg
RL-00211	CAB-8	11	5
RL-00212		11	5
RL-00213		11	5
RL-00214		10	5
RL-00411		11	5
RL-00412		11	5
RL-00413		12	5
RL-00414		13	6
RL-00811		14	6
RL-00812		15	7
RL-00813		18	8
RL-00814		20	9
RL-01211		16	7
RL-01212		17	8
RL-01213		25	11
RL-01811		16	7
RL-01812		19	9
RL-01813		34	15
RL-02511	CAB-13V	29	13
RL-02512		32	15
RL-02513		38	17
RL-03511		32	15
RL-03512		34	15
RL-03513		48	22
RL-04511		41	19
RL-04512		46	21
RL-04513		57	26
RL-05511		42	19
RL-05512		45	20
RL-05513		59	27
RL-08011		43	20
RL-08012		51	23
RL-08013		79	36
RL-10011		47	21
RL-10012		55	25
RL-10013		92	42
RL-13011	47	21	
RL-13012	61	28	
RL-13013	82	37	
RL-16011	59	27	
RL-16012	68	31	
RL-16013	85	39	

MTE AC Line / Load Reactors

User Manual

MECHANICAL DATA NEMA 1 Cont.

Catalog	Cabinet	Weight	Mass
Number	Number	Lbs	Kg
RL-20011B14	CAB-13V	56	25
RL-20012B14		72	33
RL-20013B14		118	54
RL-25011B14		65	30
RL-25012B14	CAB-17V	107	49
RL-25013B14		152	69
RL-32011B14		107	49
RL-32012B14		129	59
RL-32013B14		187	85
RL-40011B14		111	50
RL-40012B14		145	66
RL-40013B14		176	80
RL-50011	CAB-26C	120	54
RL-50012		262	119
RL-50013		354	161
RL-60011		264	120
RL-60012		319	145
RL-60013	414	188	
RL-75011	CAB-30B	299	136
RL-75012		349	158
RL-75013		424	192
RL-85011		444	202
RL-85012		529	240
RL-85013		611	277
RL-100011		479	217
RL-100012		567	257
RL-100013	748	340	
RL-120011	CAB-42C	584	265
RL-120012		599	272
RL-120013		719	326
RL-140011		803	365
RL-140012		828	376
RL-140013		1153	523
RL-150011		938	426
RL-150012		978	444
RL-150013		1203	546
RL-180011		1003	455
RL-180012		1163	528
RL-180013	1393	632	
RL-210011	1103	501	
RL-210012	1273	578	
RL-210013	1573	714	

MTE AC Line / Load Reactors

User Manual

Recommended conduit entry for Floor Mounted NEMA 1 enclosed reactors

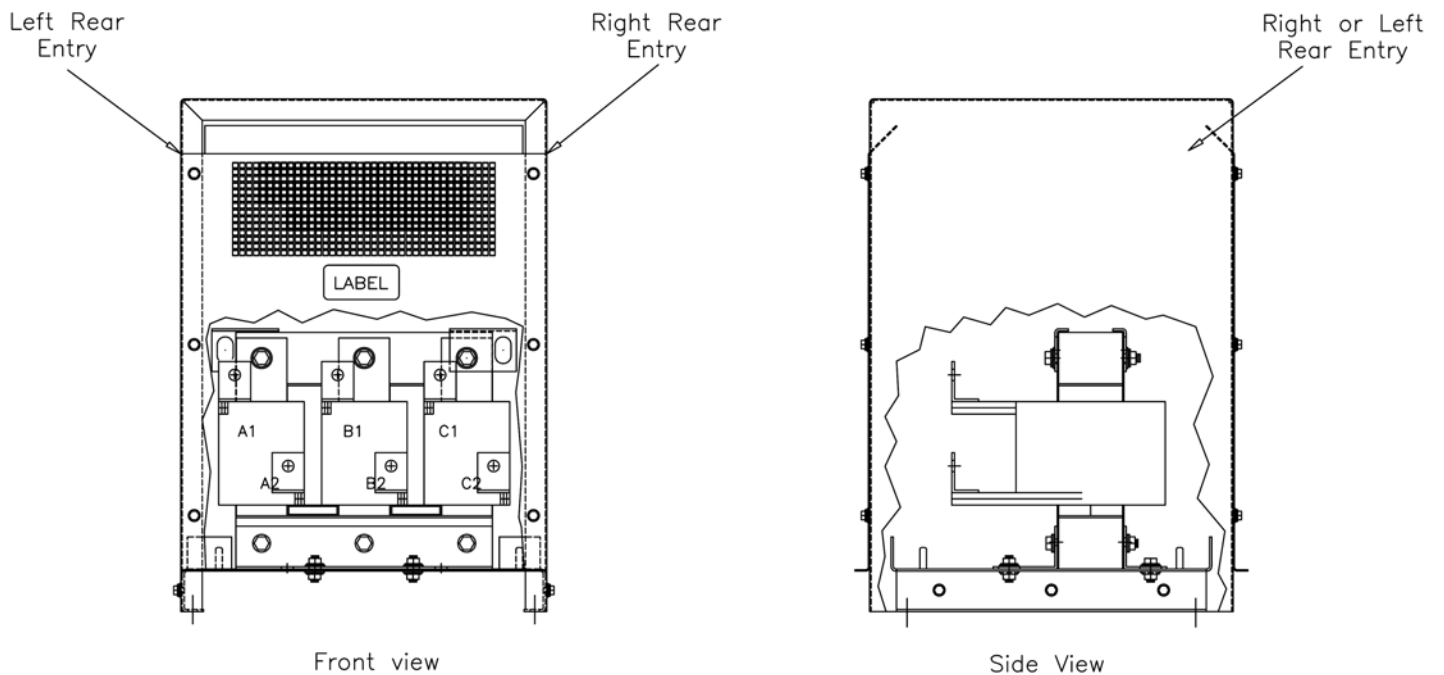

Note: The entry locations shown above are for reference only. The electrician installing the reactor guided by the local codes determines the final entry wiring. MTE does not pre-punch entry holes or provide wiring hardware with the standard product.

MTE AC Line / Load Reactors

User Manual

ENCLOSURE DIMENSIONS

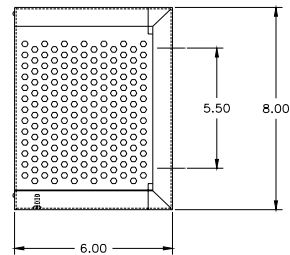
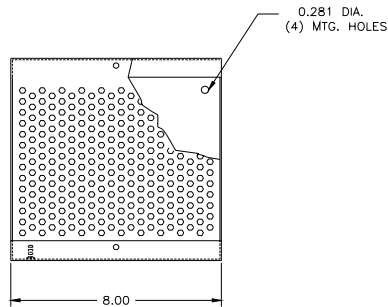
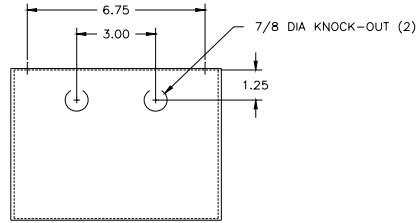

CAB-8

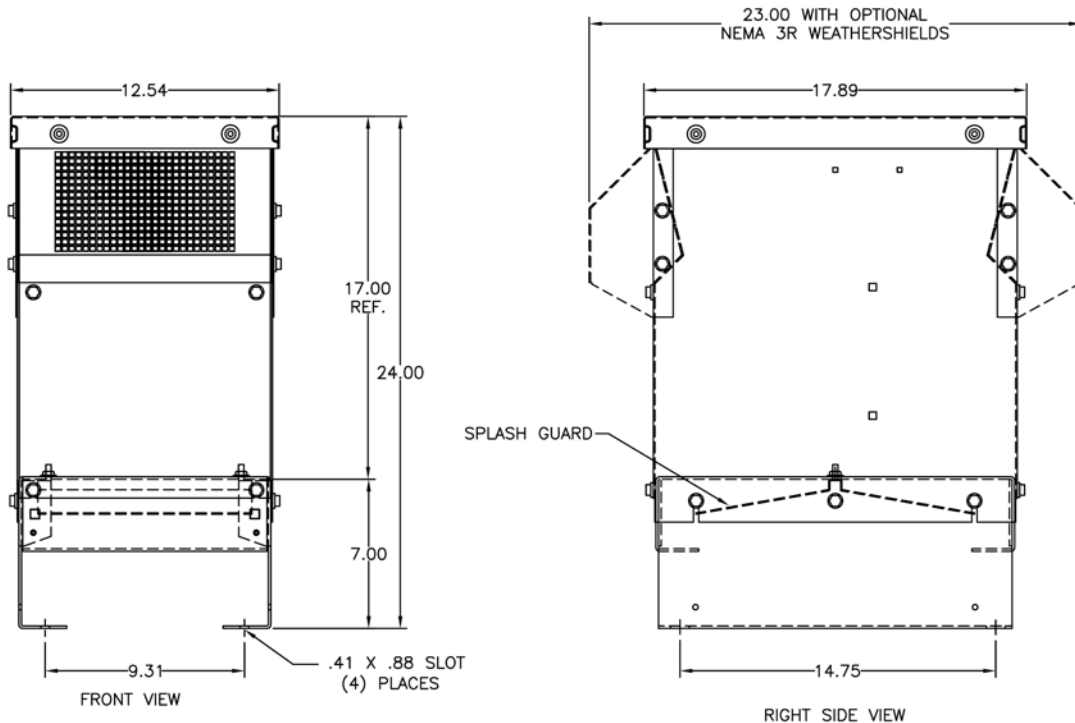

CAB-12C

MTE AC Line / Load Reactors

User Manual

ENCLOSURE DIMENSIONS

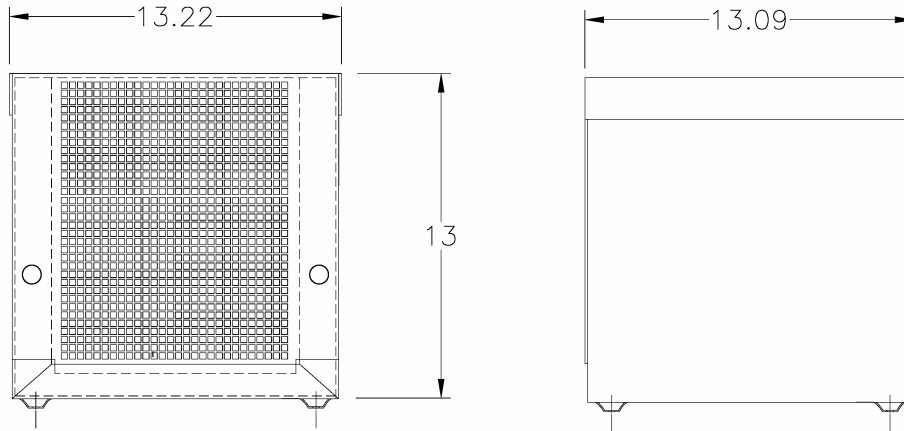

CAB-13V

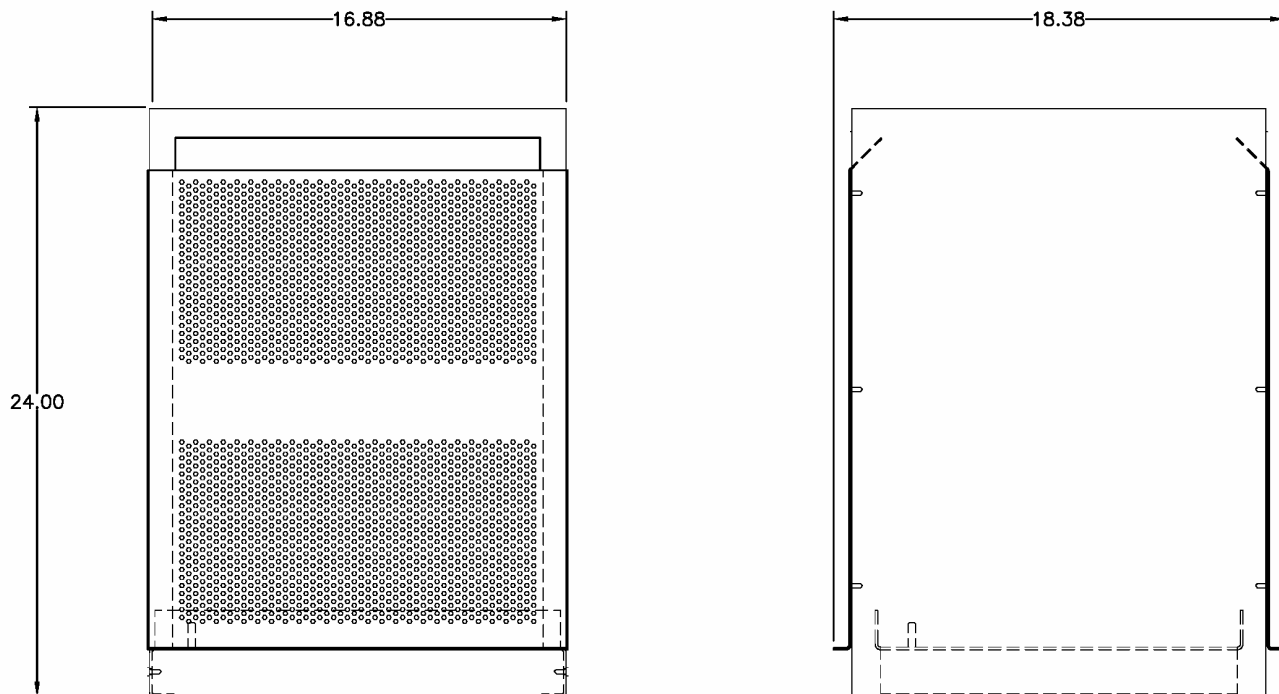

CAB-17V

MTE AC Line / Load Reactors

User Manual

ENCLOSURE DIMENSIONS

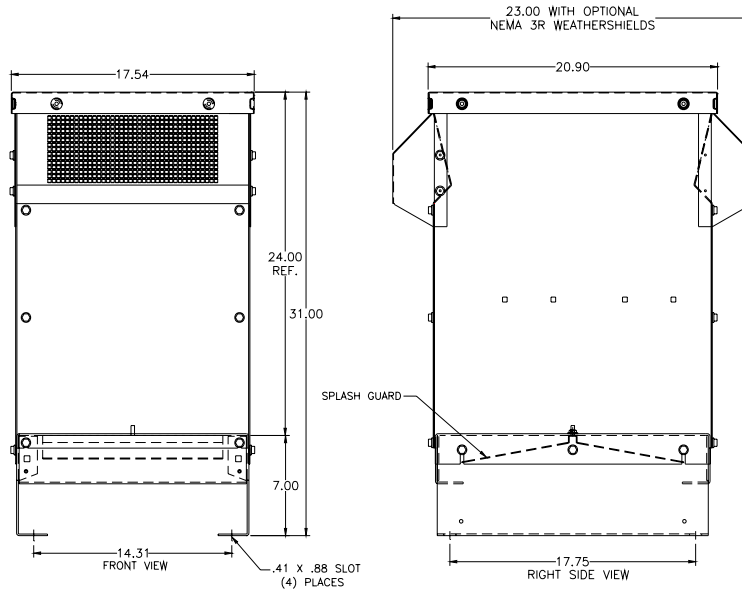

CAB-17C

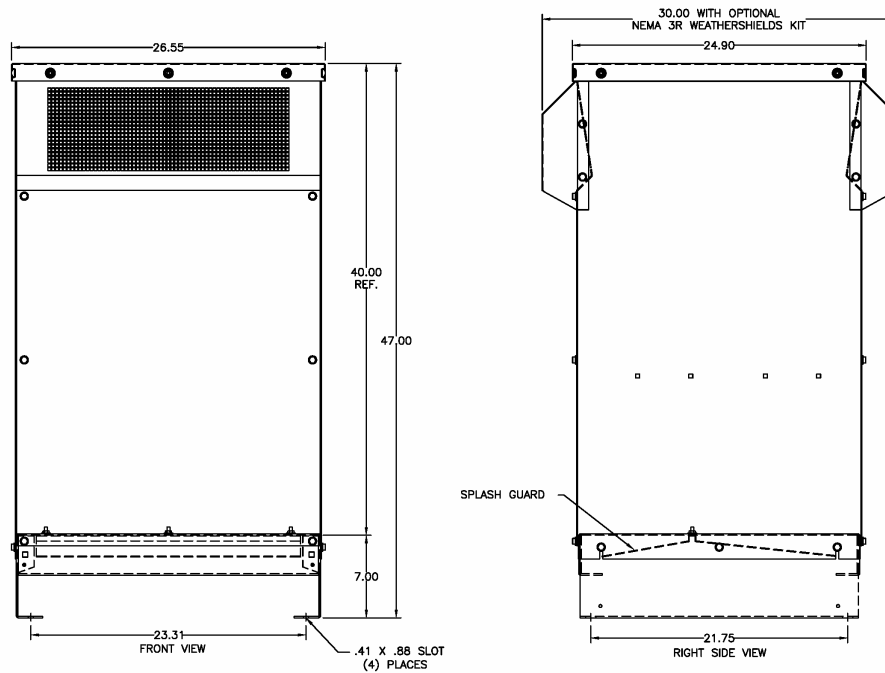

CAB-26C

MTE AC Line / Load Reactors

User Manual

TECHNICAL DATA

Catalog Number	Watts Loss (watts)	Wire Range (AWG)	Terminal Torque (in – lbs)	Ind. mH	Fund Amps	Max Amps
RL-00101	13.5	22 – 14	4.5	100	1	1.5
RL-00102	12.8	22 – 14	4.5	50	1	1.5
RL-00103	11.9	22 – 14	4.5	36	1	1.5
RL-00104	9.6	22 – 14	4.5	18	1	1.5
RL-00201	8	22 – 14	4.5	12	2	3
RL-00202	12	22 – 14	4.5	20	2	3
RL-00203	16	22 – 14	4.5	32	2	3
RL-00204	11	22 – 14	4.5	6	2	3
RL-00401	15	22 – 14	4.5	3	4	6
RL-00402	20	22 – 14	4.5	6.5	4	6
RL-00403	20	22 – 14	4.5	9	4	6
RL-00404	21	22 – 14	4.5	12	4	6
RL-00801	20	22 – 14	4.5	1.5	8	12
RL-00802	29	22 – 14	4.5	3	8	12
RL-00803	26	22 – 14	4.5	5	8	12
RL-00804	28	22 – 14	4.5	7.5	8	12
RL-01201	26	22 – 5	16	1.25	12	18
RL-01202	31	22 – 5	16	2.5	12	18
RL-01203	41	22 – 5	16	4.2	12	18
RL-01801	36	22 – 5	16	0.8	18	27
RL-01802	43	22 – 5	16	1.5	18	27
RL-01803	43	22 – 5	16	2.5	18	27
RL-02501	48	22 – 5	16	0.5	25	37.5
RL-02502	52	22 – 5	16	1.2	25	37.5
RL-02503	61	22 – 5	16	1.8	25	37.5
RL-03501	49	22 – 5	16	0.4	35	52.5
RL-03502	54	22 – 5	16	0.8	35	52.5
RL-03503	54	18 – 4	20	1.2	35	52.5
RL-04501	54	18 – 4	20	0.3	45	67.5
RL-04502	62	18 – 4	20	0.7	45	67.5
RL-04503	65	18 – 4	20	1.2	45	67.5
RL-05501	64	6 – 0	6-4(45) & 2-0(50)	0.25	55	82.5
RL-05502	67	6 – 0	6-4(45) & 2-0(50)	0.5	55	82.5
RL-05503	71	6 – 0	6-4(45) & 2-0(50)	0.85	55	82.5
RL-08001	82	6 – 0	6-4(45) & 2-0(50)	0.2	80	120
RL-08002	86	6 – 0	6-4(45) & 2-0(50)	0.4	80	120
RL-08003	96	6 – 0	6-4(45) & 2-0(50)	0.7	80	120
RL-10001	94	6 – 0	6-4(45) & 2-0(50)	0.15	100	150
RL-10002	84	6 – 0	6-4(45) & 2-0(50)	0.3	100	150
RL-10003	108	6 – 0	6-4(45) & 2-0(50)	0.45	100	150
RL-13001	108	2 – 0000	150	0.1	130	195
RL-13002	180	2 – 0000	150	0.2	130	195
RL-13003	128	2 – 0000	150	0.3	130	195
RL-16001	116	2 – 0000	150	0.075	160	240
RL-16002	149	2 – 0000	150	0.15	160	240
RL-16003	138	2 – 0000	150	0.23	160	240

MTE AC Line / Load Reactors

User Manual

TECHNICAL DATA (cont'd)

Catalog Number	Watts Loss (watts)	Wire Range (AWG)	Terminal Torque (in – lbs)	Ind mH	Fund Amps	Max Amps
RL-20001B14	124	Copper Tab	Not Applicable	0.055	200	300
RL-20002B14	168	Copper Tab	Not Applicable	0.11	200	300
RL-20003B14	146	Copper Tab	Not Applicable	0.185	200	300
RL-25001B14	154	Copper Tab	Not Applicable	0.045	250	375
RL-25002B14	231	Copper Tab	Not Applicable	0.09	250	375
RL-25003B14	219	Copper Tab	Not Applicable	0.15	250	375
RL-32001B14	224	Copper Tab	Not Applicable	0.04	320	480
RL-32002B14	264	Copper Tab	Not Applicable	0.075	320	480
RL-32003B14	351	Copper Tab	Not Applicable	0.125	320	480
RL-40001B14	231	Copper Tab	Not Applicable	0.03	400	600
RL-40002B14	333	Copper Tab	Not Applicable	0.06	400	600
RL-40003B14	293	Copper Tab	Not Applicable	0.105	400	600
RL-50001	266	Copper Tab	Not Applicable	0.025	500	750
RL-50002	340	Copper Tab	Not Applicable	0.05	500	750
RL-50003	422	Copper Tab	Not Applicable	0.085	500	750
RL-60001	307	Copper Tab	Not Applicable	0.02	600	900
RL-60002	414	Copper Tab	Not Applicable	0.04	600	900
RL-60003	406	Copper Tab	Not Applicable	0.065	600	900
RL-75001	427	Copper Tab	Not Applicable	0.015	750	1125
RL-75002	630	Copper Tab	Not Applicable	0.029	750	1125
RL-75003	552	Copper Tab	Not Applicable	0.048	750	1125
RL-85001	798	Copper tab	Not Applicable	0.015	850	1063
RL-85002	930	Copper tab	Not Applicable	0.027	850	1063
RL-85003	1133	Copper tab	Not Applicable	0.042	850	1063
RL-90001	860	Copper tab	Not Applicable	0.013	900	1125
RL-90002	1020	Copper tab	Not Applicable	0.025	900	1125
RL-90003	1365	Copper tab	Not Applicable	0.04	900	1125
RL-100001	940	Copper tab	Not Applicable	0.011	1000	1250
RL-100002	1090	Copper tab	Not Applicable	0.022	1000	1250
RL-100003	1500	Copper tab	Not Applicable	0.038	1000	1250
RL-120001	980	Copper tab	Not Applicable	0.009	1200	1500
RL-120002	1130	Copper tab	Not Applicable	0.019	1200	1500
RL-120002	1550	Copper tab	Not Applicable	0.03	1200	1500
RL-140001		Copper tab	Not Applicable	0.008	1400	1750
RL-140002	1523	Copper tab	Not Applicable	0.016	1400	1750
RL-140003	1680	Copper tab	Not Applicable	0.027	1400	1750
RL-150001	1432	Copper tab	Not Applicable	0.008	1500	1875
RL-150002	1671	Copper tab	Not Applicable	0.015	1500	1875
RL-150003	1815	Copper tab	Not Applicable	0.025	1500	1875

Contact factory for higher ratings.

MTE AC Line / Load Reactors

User Manual

INSTALLATION INSTRUCTIONS

Open Line/Load Reactor Installation

MTE line/load reactors are available in open construction and in NEMA 1 enclosures. Open reactors are designed for mounting within an appropriate electrical equipment enclosure. Reactors rated 300 amperes RMS and under are designed for mounting in both a vertical and horizontal position. Larger reactors must be mounted in a horizontal position typically on the floor of the enclosure. Include the power dissipation of the reactor along with all the other components located in the enclosure to determine the internal temperature rise and cooling requirements of the enclosure.

Reactors may be located in any region of the enclosure where the ambient temperature does not exceed 45 degrees C. Allow a minimum side clearances of four (4) inches and vertical clearances of six (6) inches for proper heat dissipation and access. Do not locate the reactor next to resistors or any other component with operating surface temperatures above 125 degree C.

Select a well ventilated, dust-free area away from direct sunlight, rain or moisture. Do not install in or near a corrosive environment. Avoid locations where the reactor will be subjected to excessive vibrations.

NEMA 1 Line/Load Reactor Installation

Top conduit entry recommended for NEMA 1 enclosed reactors.

MTE line/load reactors mounted in enclosures with part number, CAB-8, are designed for wall mounting. All other enclosures are designed for floor mounting.

WARNING

MTE NEMA 1 enclosures designed for floor mounting must be mounted with the enclosure base horizontal for proper ventilation. Wall mounting a floor mounted enclosure with the base against the wall will cause the reactor to over heat resulting in equipment damage.

Allow a minimum side, **front**, and **back clearances** of **twelve (12)** inches and **vertical clearances** of **eighteen (18)** inches for proper heat dissipation and access. Do not locate the enclosure next to resistors or any other component with operating surface temperatures above 125 degree C.

Select a well ventilated, dust-free area away from direct sunlight, rain or moisture where the ambient temperature does not exceed 40 degrees C.

Do not install in or near a corrosive environment.

Avoid locations where the reactor will be subjected to excessive vibrations.

Where desirable, enclosures may be mounted on vibration isolating pads to reduce audible noise. Standard vibration control pads made from neoprene or natural rubber and selected for the weight of the enclosed reactor are effective. Using flexible conduit is also helpful in abatement of audible noise.

MTE AC Line / Load Reactors

User Manual

Power Wiring Connection

WARNING

Input and output power wiring to the reactor should be performed by authorized personnel in accordance with the NEC and all local electrical codes and

REGULATIONS

Verify that the power source to which the reactor is to be connected is in agreement with the nameplate data on the reactor. A fused disconnect switch or circuit breaker should be installed between the reactor and its source of power in accordance with the requirements of the NEC and all local electrical codes and regulations. Refer to the drive, inverter, or other electrical equipment user manual for selection of the correct fuse rating and class.

The reactor is suitable for use on a circuit capable of delivering not more than 65,000 rms symmetrical amperes at 480 volts when protected by Bussman type JJS, KTK, KTK-R, SPP or T class fuses.

Reactors are designed for use with copper conductors with a minimum temperature rating of 75 degrees C. Table 2 lists the wire range and terminal torque requirements for the power input and output connections by reactor part number.

Refer to Figure 4 for typical electrical diagrams describing the application of reactors in both line and load applications. For reactors supplied as a component part of a drive system or a component part of power electronic apparatus follow the interconnection diagram supplied by the System Engineer.

Where desirable, a flexible conduit connection to the reactor enclosure should be made to reduce audible noise.

WARNING

Failure to connect reactors supplied as a component part of a drive system or other power electronic system according to the system interconnection diagram supplied by the System Engineer will result in equipment damage, injury, or death.

WARNING

If a line reactor or a line reactor and a load reactor are used with a drive equipped with a bypass circuit, the reactors must be removed from the motor circuit in the bypass mode. Damage to the motor and other equipment will result if this warning is not observed.

Grounding

A stud is provided on enclosed reactors for grounding the enclosure. The enclosure must be grounded. Open reactors must be grounded at the designated grounding terminal or the reactor mounting holes if no designated grounding terminal is provided.

WARNING

The frame of line/load reactors must be grounded at the designated grounding terminal or one of the reactor mounting holes if no designated grounding terminal is provided. The enclosure of reactors supplied in enclosures must be grounded.

INJURY OR DEATH MAY RESULT IF SAFETY PRECAUTIONS ARE NOT OBSERVED.

MTE AC Line / Load Reactors

User Manual

Typical Connection Diagrams

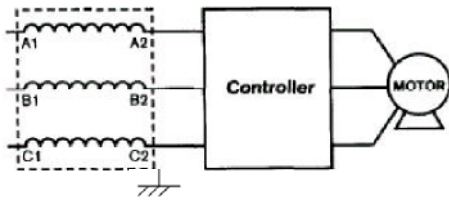

Fig 4a LINE Reactor

Connects between power source and VFD

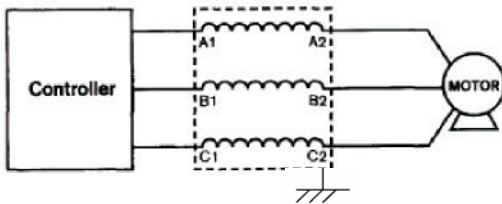

Fig. 4b LOAD Reactor

Connects between ASD and load (motor)

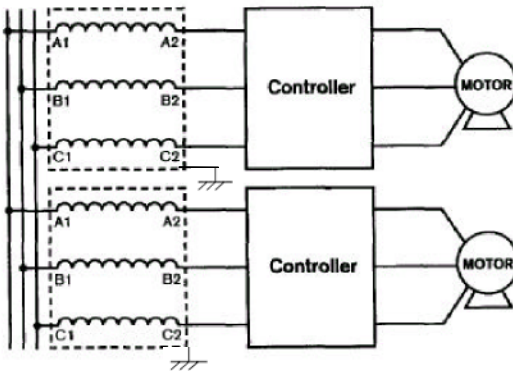

Fig 4c Use individual Line Reactors for independent start/ stop drives connected to a common power source. If inverters are slaved and will always run together a single reactor sized for total motor current may be used.

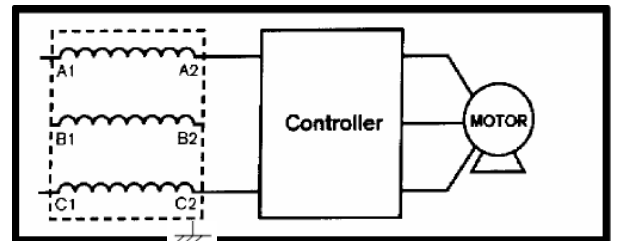

Figure 5. Single Phase connection diagram.

Standard three phase reactors may be used for single phase applications. Refer to application note AN0102 for proper selection. Application Notes are available on our website at www.mtecorp.com.

MTE AC Line / Load Reactors

User Manual

Sequence of Operation

1. Read and follow safety precautions.
2. After installation, ensure that:
 - All Reactor ground terminals are connected to ground.
 - Power wiring to the utility, drive and motor is in accordance with the interconnection diagrams supplied by the System Engineer.
3. Check that moisture has not condensed on the Reactor. If moisture is present, do not proceed with startup until the moisture has been removed.
4. Proceed with startup according to the instructions provided by the system supplier.

WARNING

Reactors are a component part of an electrical system. Do not proceed with startup until the system startup instructions provided by the System Engineer are understood and followed. Injury, death and damage to equipment may result if the system startup instructions are not followed.

WARNING

Use extreme caution to avoid contact with line voltage when checking for power.

INJURY OR DEATH MAY RESULT IF SAFETY PRECAUTIONS ARE NOT OBSERVED.

MTE AC Line / Load Reactors

User Manual

STARTUP

Safety Precautions

Before startup, observe the following warnings and instructions:

WARNING

A Reactor is at line potential when the Reactor is connected to the utility. This voltage is extremely dangerous and may cause death or severe injury if you come in contact with it.

WARNING

High voltage is used in the operation of line/load reactors. Use Extreme caution to avoid contact with high voltage when operating, installing or repairing equipment containing line/load reactors. Line/load reactors are used in conjunction with inverters, or other electrical equipment that may feedback lethal voltages.

Follow the safety instructions in the equipment used with the reactor in addition to the safety instruction in this manual.

INJURY OR DEATH MAY RESULT IF SAFETY PRECAUTIONS ARE NOT OBSERVED.