

MTE Corporation

MATRIX FILTER™

SERIES A

480 Volts 60 Hz

USER MANUAL

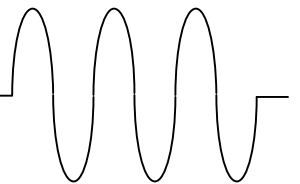

PART NO. INSTR - 002
REL. 060607

© 2000 MTE Corporation

IMPORTANT USER INFORMATION

NOTICE

The MTE Corporation Matrix Filter is designed for harmonic mitigation of six pulse inverter drives supplying variable torque loads in a wide variety of applications. The suitability of this filter for a specific application must therefore be determined by the customer. In no event will MTE Corporation assume responsibility or liability for any direct or consequential damages resulting from the use or application of this filter. Nor will MTE Corporation assume patent liability with respect to the use of information, circuits or equipment described in this instruction manual.

TABLE OF CONTENTS

1. Safety	1
2. Introduction	3
3. Model Number Codes	4
4. Specifications	5
Ratings	5
Service Conditions	5
Performance	6
Altitude Derating Curve	10
5. Installation Instructions	11
Filter Installation	11
Power Wiring Connection	11
Ground and Ground Fault Protection	12
Input and Output Terminal Specifications	12
Outline Drawings and Mounting Dimensions	13
Interconnection Diagrams	23
6. Filter Description	26
7. Start – Up	28
8. Troubleshooting	29
8. Addendum A	33

1. IMPORTANT SAFETY INFORMATION

WARNING

ONLY A QUALIFIED ELECTRICIAN CAN CARRY OUT THE ELECTRICAL INSTALLATION OF THIS FILTER

WARNING

High voltage is used in the operation of this filter. Use Extreme caution to avoid contact with high voltage when operating, installing or repairing this filter. **INJURY OR DEATH MAY RESULT IF SAFETY PRECAUTIONS ARE NOT OBSERVED.**

After removing power, allow at least five minutes to elapse and verify that the capacitors have discharged to a safe level before contacting internal components. Connect a DC voltmeter across the capacitor terminals 1, 2 and 3 on terminal block 1TB. Start with the meter on the highest scale and progressively switch to a lower scale as the indicated voltage falls below the maximum value of the scale used.

WARNING

The opening of the branch circuit protective device may be an indication that a fault current has been interrupted. To reduce the risk of fire or electrical shock, current-carrying parts and other components of the filter should be examined and replaced if damaged.

WARNING

An upstream disconnect/protection device must be used as required by the National Electrical Code (NEC).

WARNING

Even if the upstream disconnect/protection device is open, the drive down stream of the filter may feed back high voltage to the filter. The drive safety instructions must be followed. **INJURY OR DEATH MAY RESULT IF THE DRIVE SAFETY PRECAUTIONS ARE NOT OBSERVED.**

WARNING

The filter must be grounded with a grounding conductor connected to all grounding terminals.

WARNING

Only spare parts obtained from MTE Corporation or an authorized MTE distributor can be used.

2. INTRODUCTION

This manual was specifically developed to assist in the installation, interconnection and operation of the MTE Corporation Matrix Filter.

This manual is intended for use by personnel experienced in the operation and maintenance of electronic drives. Because of the high voltages required by the filter and drive and the potential dangers presented by rotating machinery, it is essential that all personnel involved in the operation and maintenance of this filter know and practice the necessary safety precautions for this type of equipment. Personnel should read and understand the instructions contained in this manual before installing, operating or servicing the filter and the drive to which the filter is connected.

Upon Receipt of this Filter:

The MTE Matrix Filter has been subjected to demanding factory tests before shipment. Carefully inspect the shipping container for damage that may have

occurred in transit. Then unpack the filter and carefully inspect for any signs of damage. Save the shipping container for future transport of the filter.

In the event of damage, please contact and file a claim with the freight carrier involved immediately.

If the equipment is not going to be put into service upon receipt, cover and store the filter in a clean, dry location. After storage, ensure that the equipment is dry and that no condensation has accumulated on the internal components of the filter before applying power.

Repair/Exchange Procedure

MTE Corporation requires a Returned Material Authorization Number before it can accept any filters that qualify for return or repair. If problems or questions arise during installation, setup, or operation of the filter, please call us for assistance at:

Phone: 262-253-8200

FAX: 262-253-8222

3. MODEL NUMBER CODES

Standard series A model number codes are of the form MA-BCDEFG-XY with the number coded as outlined below.

Character	Description	Code
M	Always M for Matrix Filter	
A	Designates number of input phases	1 Single phase 3 Three phase
B	Characters B through E designate the Horsepower rating of the filter using four digits with leading zeros	<i>Example: 0075 is a 75 Hp filter</i>
C		
D		
E		
F	Indicates mechanical configuration	N Nema1 R Reactive components only M Magnetic components only P Panel mounted W Weather proof D Dust tight H Hose down
G	Designates input voltage and frequency	A 208-240 v / 60Hz B 240 v / 50 Hz C 380-415 v / 50 Hz D 480 v / 60 Hz E 600 v / 60 Hz F 690 v / 50 Hz G 690 v / 60 Hz H 120 v / 60 Hz J K L 277 v / 60Hz
XY	Designates filter guaranteed harmonic current performance	12 is 12% THID 8 is 8% THID

4. SPECIFICATIONS

Ratings

480 VAC Three Phase Input Filter Ratings (Panel Mounted)*								
THID Rating			12%			8%		
HP	Maximum Input Amps RMS	Maximum Output Amps RMS	Efficiency (Typical) (%)	Power Dissipation @ Rated HP (Typical) (Watts)	Weight (lbs)	Efficiency (Typical) (%)	Power Dissipation @ Rated HP (Typical) (Watts)	Weight (lbs)
3	6	6	97	47	27	98	40	37
5	9	10	98	66	35	98	63	42
7.5	13	14	98	98	35	98	98	42
10	16	18	98	114	45	98	108	60
15	24	27	98	166	50	98	170	75
20	31	34	98	204	85	98	212	100
25	39	43	98	275	85	98	257	100
30	46	51	98	295	105	98	323	130
40	60	66	98	390	125	98	374	155
50	75	82	98	475	150	98	506	190
60	89	97	98	586	150	98	584	190
75	110	121	98	659	200	98	655	250
100	143	157	98	837	215	98	838	280
125	179	197	98	971	250	98	1051	305
150	207	228	99	1018	275	99	1057	340
200	276	304	98	1521	380	98	1775	600
250	347	382	99	1767	450	98	1889	675
300	415	457	99	1994	575	99	2099	750

*Refer to Addendum A for Enclosed Current Ratings

Service Conditions

Load: 6 pulse variable torque rectifier only

Input voltage: 480 VAC +/- 10%, 60 ± 0.75 Hz, 3 phase

Input voltage line unbalance: 1% maximum

Maximum source impedance: 6.00%

Minimum source impedance: 1.5%

Service Factor: 1.00

SPECIFICATIONS – continued

Ambient Temperature

Operating: -40 to +50 degrees C (panel mounted construction)
Storage: -40 to +90 degrees C

Altitude: 0 to 3300 Feet above sea level. Refer to Figure 1 for altitude derating.

Relative Humidity: 0 to 95% non-condensing

Agency Approvals

UL-508	File E180243 Component Recognized (3-1000 HP, 120 VAC through 600 VAC 50, 50/60, 60 HZ Three Phases
CAN/CSA	C22, 2 No. 14-95

Performance

Total Harmonic Current Distortion:

Standard: 12% maximum no load to full load

Optional: 8% maximum no load to full load

Standby Current:

Without Optional Capacitor Contactor: Refer to Table 1

With Optional Capacitor Contactor: Refer to Drive Users Manual

12% Filter Voltage Regulation with nominal 480 volts RMS source

Maximum output voltage at no load: 502 volts RMS, 710 volts peak

Maximum PCC* voltage with 6.00% source impedance at no load: 490 volts RMS, 693 volts peak

Minimum output voltage at full load: 460 volts RMS, 600 volts peak

8% Filter Voltage Regulation with nominal 480 volts RMS source

Maximum output voltage at no load: 502 volts RMS, 710 volts peak

Maximum PCC voltage with 6.00% source impedance at no load: 490 volts RMS, 693 volts peak

Minimum output voltage at full load: 460 volts RMS, 600 volts peak

*Note: PCC is the point of common coupling with the power distribution system

SPECIFICATIONS - continued

**Table 1. 480 VAC Three Phase Input Filters
Standby Current Ratings Without Optional Capacitor Contactor**

HP	Standby Current (Typical) Amps RMS	HP	Standby Current (Typical) Amps RMS	HP	Standby Current (Typical) Amps RMS
3	1.7	25	11.0	100	41.0
5	2.3	30	16.0	125	64.0
7-1/2	4.0	40	16.0	150	81.0
10	4.5	50	23.0	200	101.0
15	7.9	60	23.0	250	121.0
20	11.0	75	27.0	300	148.0

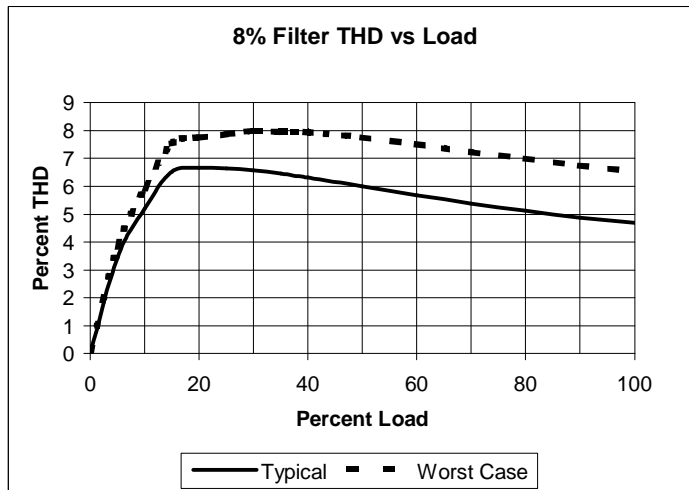
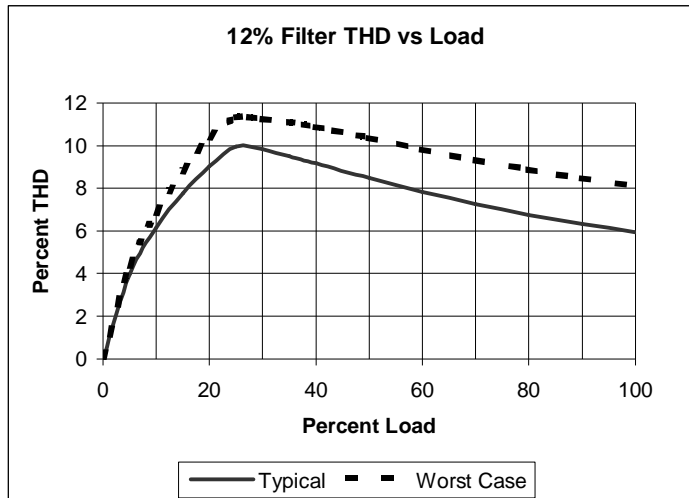

SPECIFICATIONS – continued

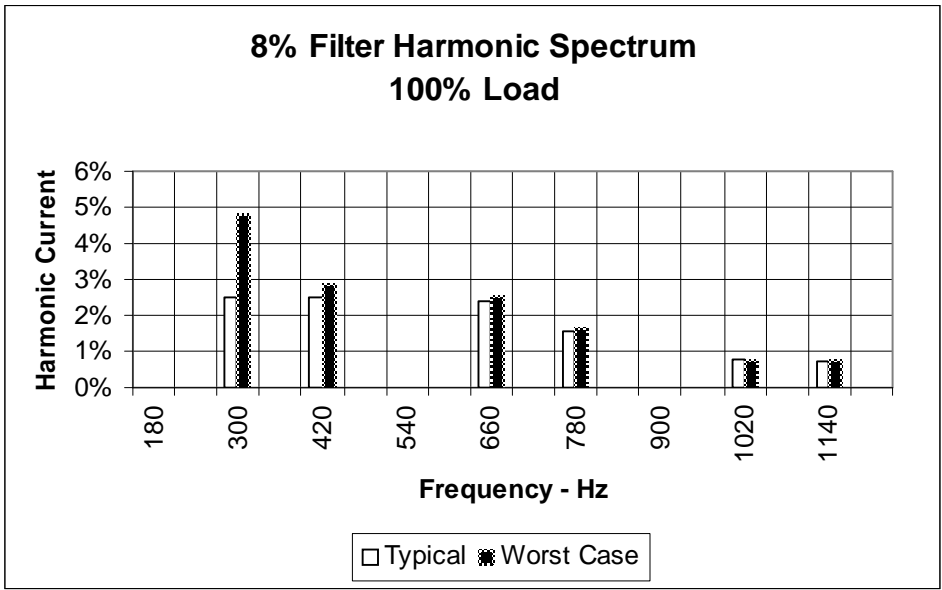
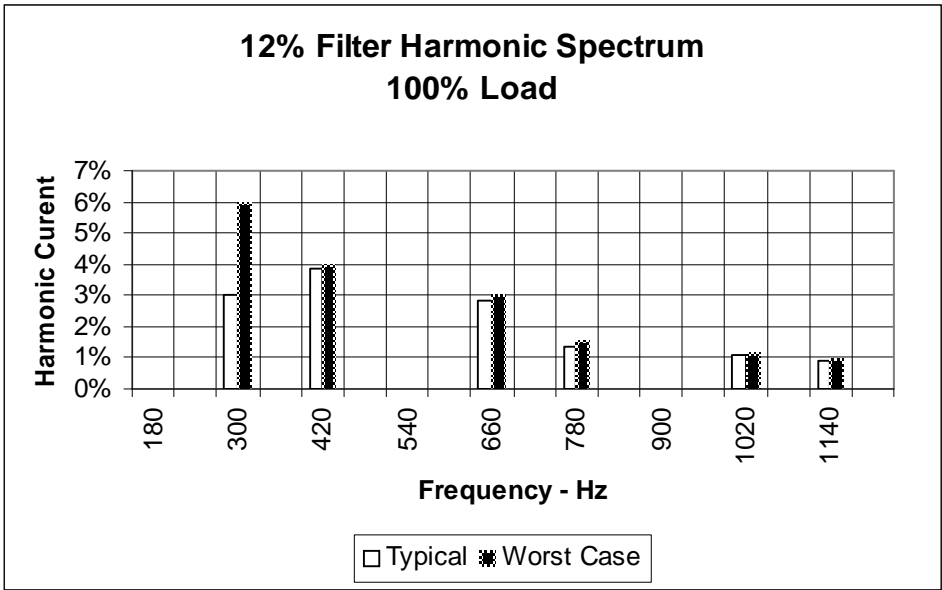

SPECIFICATIONS - continued

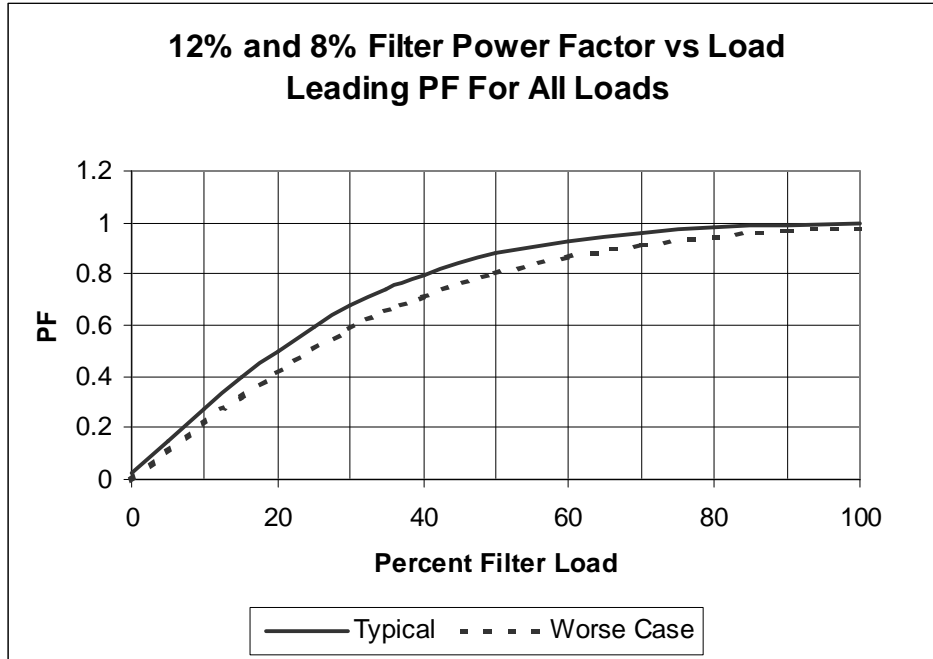

Performance With Unbalanced Line Voltage (Typical)

All Components at Nominal Values and Worse Case Service Conditions		
	12% Filter 100% Load	8% Filter 100% Load
Nominal THID	5.85%	4.71%
1% Unbalance	6.09%	4.92%
2% Unbalance	6.64%	5.46%
3% Unbalance	7.45%	6.29%
	12% Filter 30% Load	8% Filter 30% Load
Nominal THID	9.38%	6.42%
1% Unbalance	9.79%	6.90%
2% Unbalance	10.97%	8.13%
3% Unbalance	12.66%	9.80%

Figure 1. Altitude Derating Curve

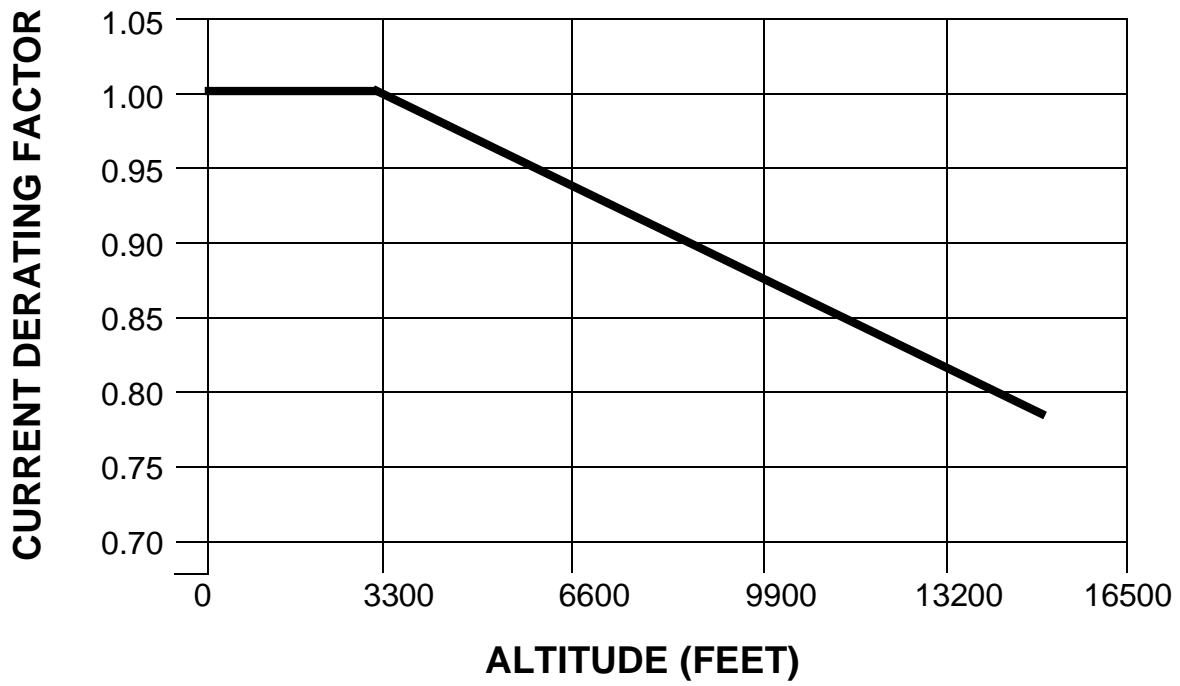

5. INSTALLATION INSTRUCTIONS

Filter Installation

Panel mounted filters are designed for mounting in the vertical plane in the customer's enclosure. Include the power dissipation of the filter along with all the other components located in the panel to determine the internal temperature rise and cooling requirements of the enclosure.

Select a well ventilated, dust-free area away from direct sunlight, rain or moisture.

Do not install in or near a corrosive environment.

Avoid locations where the filter would be subjected to excessive vibrations.

The Matrix Filters are supplied as sub-panel and panel mountable components that are designed to be mounted in a vertical position on a main panel located within an appropriate electrical enclosure. Allow minimum side clearances of four (4) inches and vertical clearances of six (6) inches for proper heat dissipation and access. Figures 2 through 11 contain outline drawings for the various ratings and show proper mounting orientation.

Power Wiring Connection

WARNING

Input and output power wiring to the filter should be performed by authorized personnel in accordance with the NEC and all local electrical codes and regulations.

Verify that the power source to which the filter is to be connected is in agreement with the nameplate data on the filter. A fused disconnect switch or circuit breaker should be installed between the filter and its source of power in accordance with the requirements of the NEC and all local electrical codes and regulations. Refer to the drive user manual for selection of the correct fuse rating and class.

The filter is suitable for use on a circuit capable of delivering not more than 100,000 rms symmetrical amperes at 480 volts when protected by Bussman type JJS, KTK, KTK-R, SPP or T class fuses.

For 480VAC applications rated 15 Hp and below, interconnection between the filter, its power source, and the drive is shown in Figure 12. Refer to the drive user manual for instructions on interconnecting the drive and motor and the correct start-up procedures for the drive.

The filter is designed for use with copper conductors with a minimum temperature rating of 75 degrees C. Table 2 lists the wire range and terminal torque requirements for the power input and output connections by horsepower rating.

For 480 VAC filters rated 20 Hp or more, the filter reactors are supplied on a sub-panel and the filter capacitors are supplied on one or more assemblies. Refer to Figure 13 for the interconnection diagram. The capacitor assembly should be located in the lowest temperature regions of the enclosure – generally toward the bottom – and the reactor assembly may be located in any region where the ambient temperature does not exceed 50 degrees C. Size the conductors interconnecting the reactor and capacitor assemblies to carry the current shown in Table 3. For terminal specifications on the capacitor assembly, refer to Table 4.

INSTALLATION INSTRUCTIONS – continued

Grounding and Ground Fault Protection

The filter must always be grounded with a grounding conductor connected to all ground terminals.

Due to high leakage currents associated with variable frequency drives, ground fault protective devices do not necessarily operate correctly when placed ahead of a matrix filter feeding a drive. When using this type of device, its function should be tested in the actual installation.

Table 2. Input and Output Terminal Specifications

Filter Rating(HP)	Input Terminals		Output Terminals	
	Wire Range (AWG)	Terminal Torque (in-lbs)	Wire Range (AWG)	Terminal Torque (in-lbs)
3	22 -14	4.5	22 – 14	4.5
5	22 - 14	4.5	22 – 14	4.5
7.5	22 - 14	4.5	22 – 5	16
10	22 - 5	16	22 – 5	16
15	22 - 5	16	22 – 5	16
20	22 - 5	16	18 – 4	20
25	22 - 5	16	18 – 4	20
30	18 – 4	20	18 – 4	20
40	18 – 4	20	6-4 2-0	45 50
50	6-4 2-0	45 50	6-4 2-0	45 50
60	6-4 2-0	45 50	6-4 2-0	45 50
75	6-4 2-0	45 50	6-4 2-0	45 50
100	6-4 2-0	45 50	2-0000	150
125	2 – 0000	150	2 – 0000	150
150	2 – 0000	150	2 – 0000	150
200	2-0000	150	00 000-0000 250-350 MCM 500 MCM	180 250 325 375
250	00 000-0000 250-350 MCM 500 MCM	180 250 325 375	00 000-0000 250-350 MCM 500 MCM	180 250 325 375
300	00 000-0000 250-350 MCM 500 MCM	180 250 325 375	00 000-0000 250-350 MCM 500 MCM	180 250 325 375

INSTALLATION INSTRUCTIONS – continued

Figure 2. 3 – 10 HP, 480 VAC Outline Drawing

All dimensions are in inches

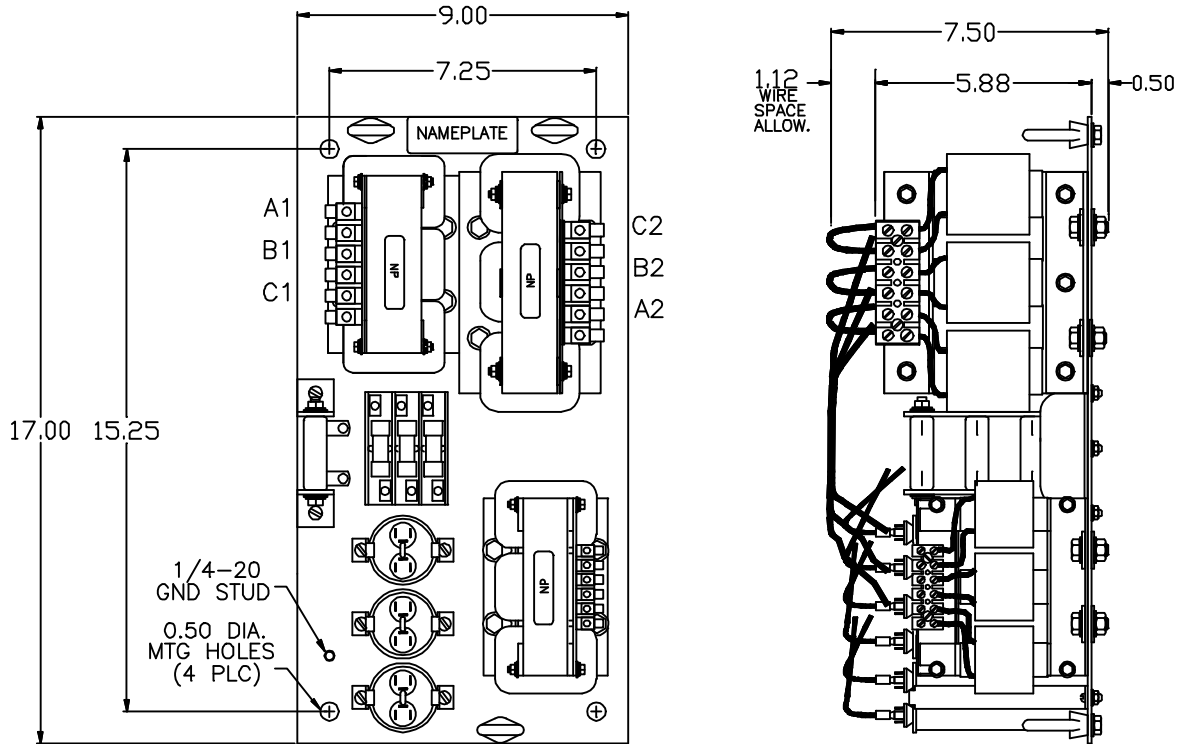

INSTALLATION INSTRUCTIONS – continued

Figure 3. 15 HP, 480 VAC Outline Drawing

All dimensions are in inches

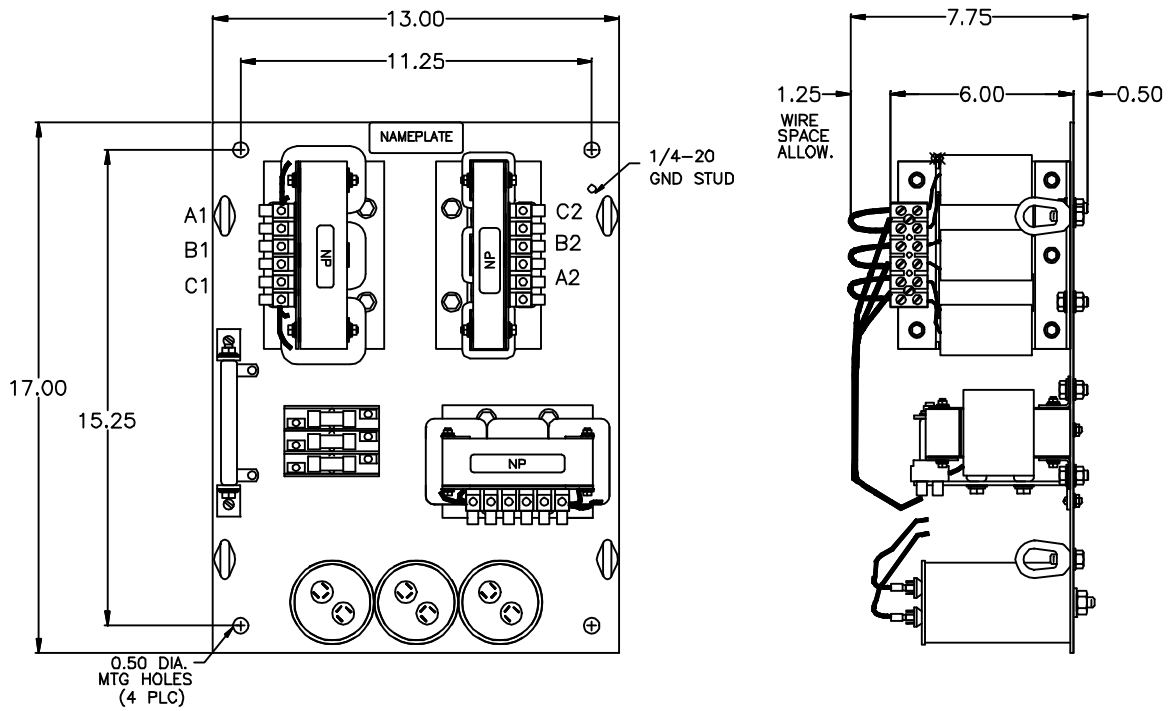

INSTALLATION INSTRUCTIONS – continued

Figure 4. 20 - 40 HP, 480 VAC Outline Drawing

All dimensions are in inches

REACTOR ASSEMBLY

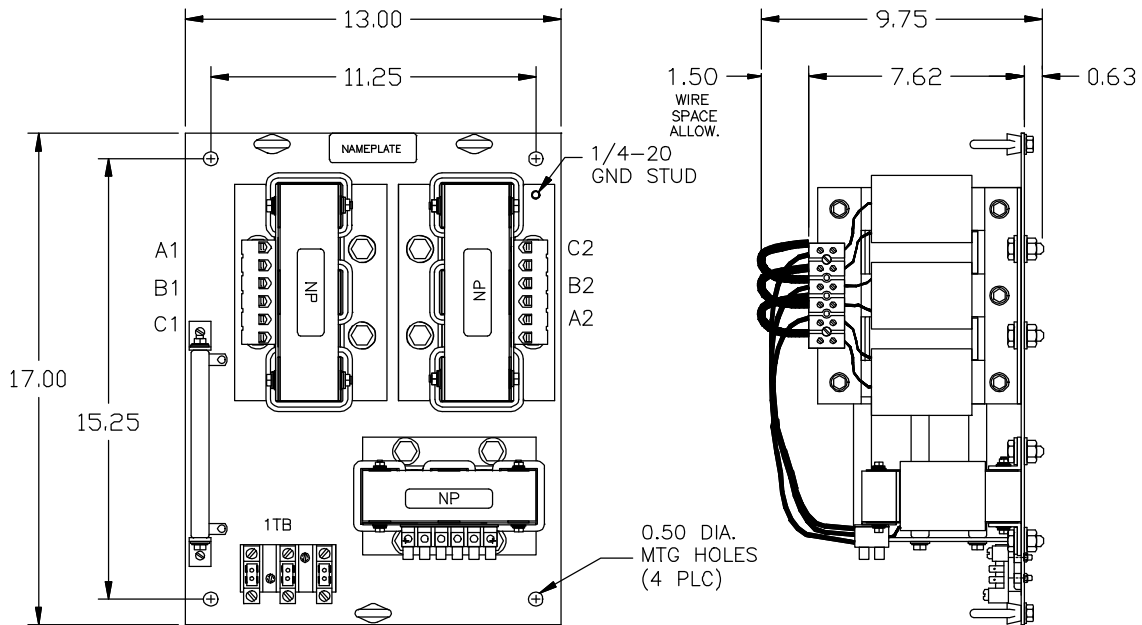

CAPACITOR ASSEMBLY

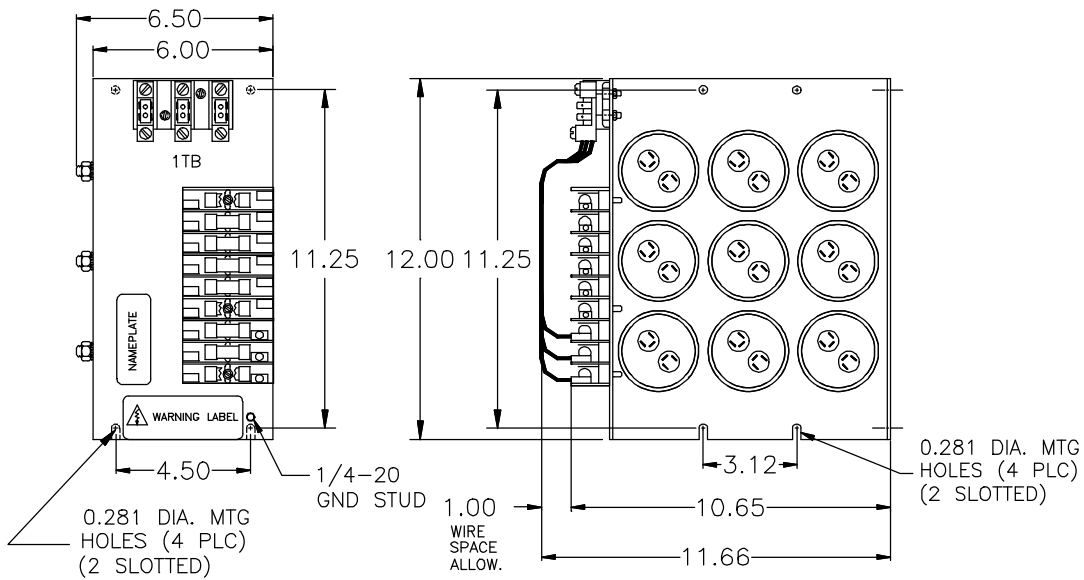

NOTE: CAPACITOR ASSEMBLY MAY BE MOUNTED IN EITHER PLANE

INSTALLATION INSTRUCTIONS – continued

Figure 5. 50 - 60 HP, 480 VAC Outline Drawing

All dimensions are in inches

REACTOR ASSEMBLY

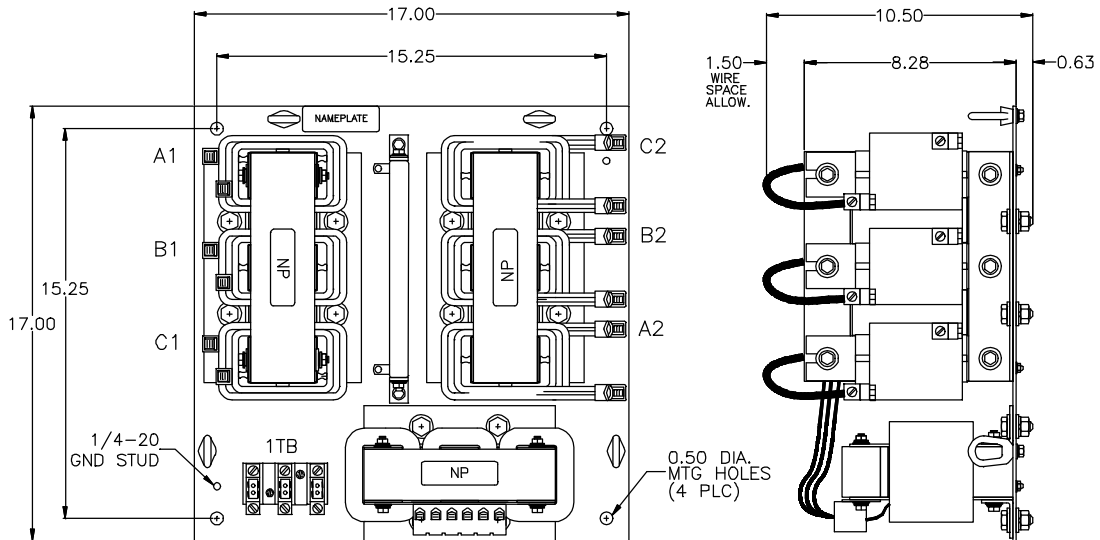

CAPACITOR ASSEMBLY

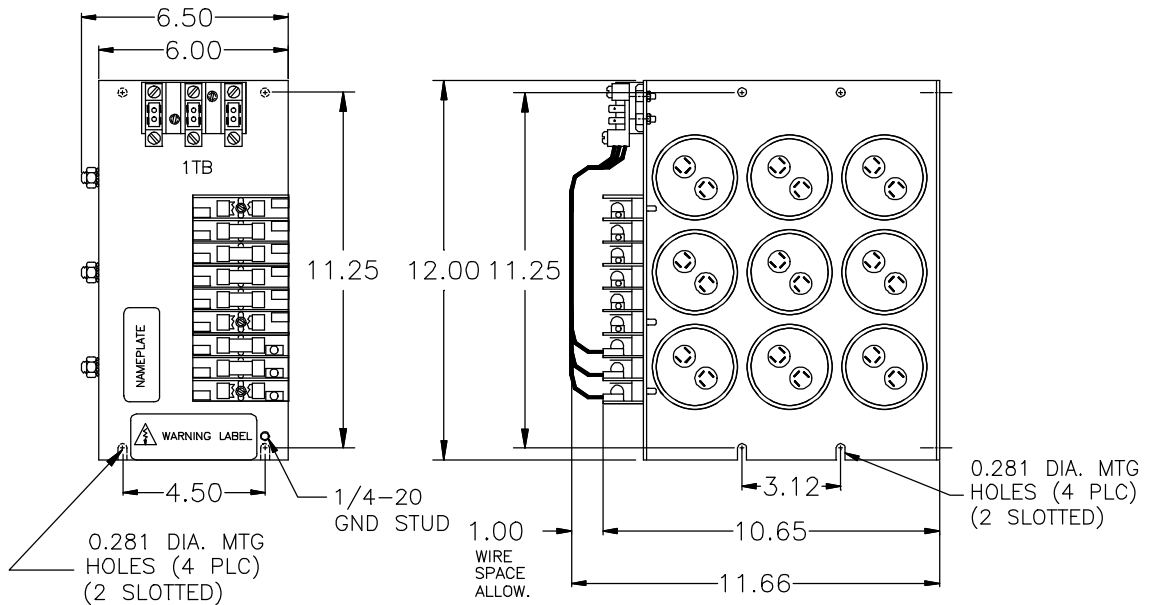

NOTE: CAPACITOR ASSEMBLY MAY BE MOUNTED IN EITHER PLANE

INSTALLATION INSTRUCTIONS – continued

Figure 6. 75 HP, 480 VAC Outline Drawing

All dimensions are in inches

REACTOR ASSEMBLY

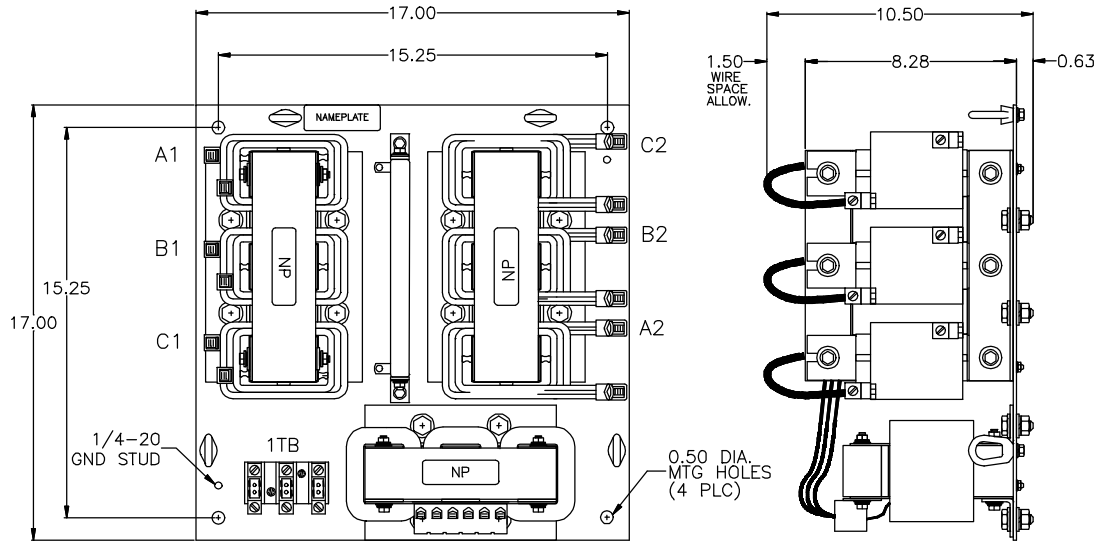

CAPACITOR ASSEMBLY

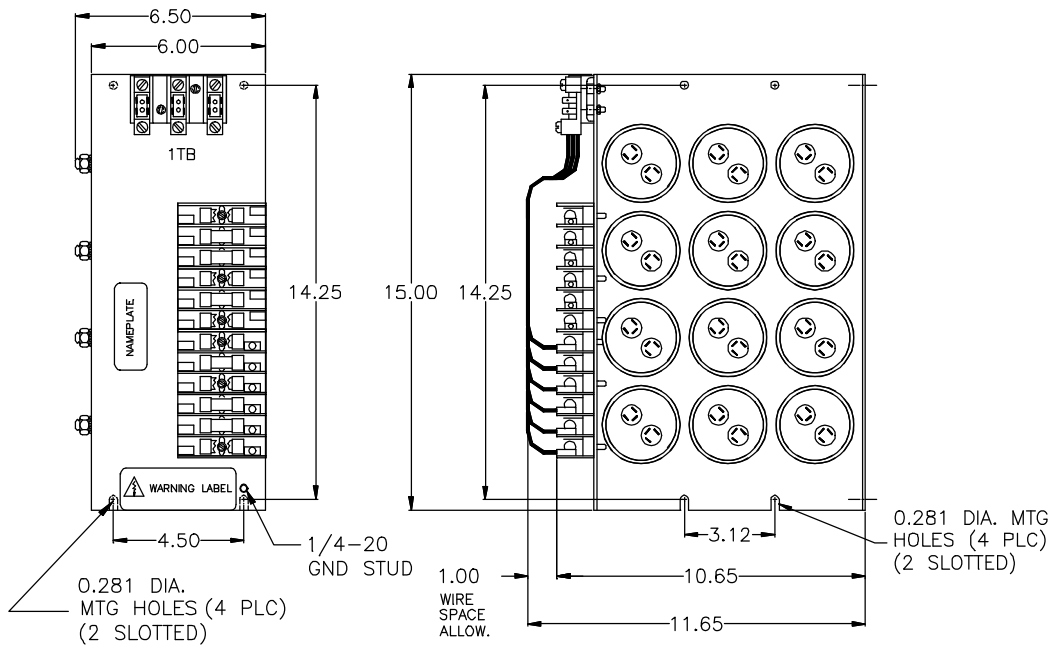

NOTE: CAPACITOR ASSEMBLY MAY BE MOUNTED IN EITHER PLANE

INSTALLATION INSTRUCTIONS – continued

Figure 7. 100 HP, 480 VAC Reactor Assembly Outline Drawing

All dimensions are in inches

REACTOR ASSEMBLY

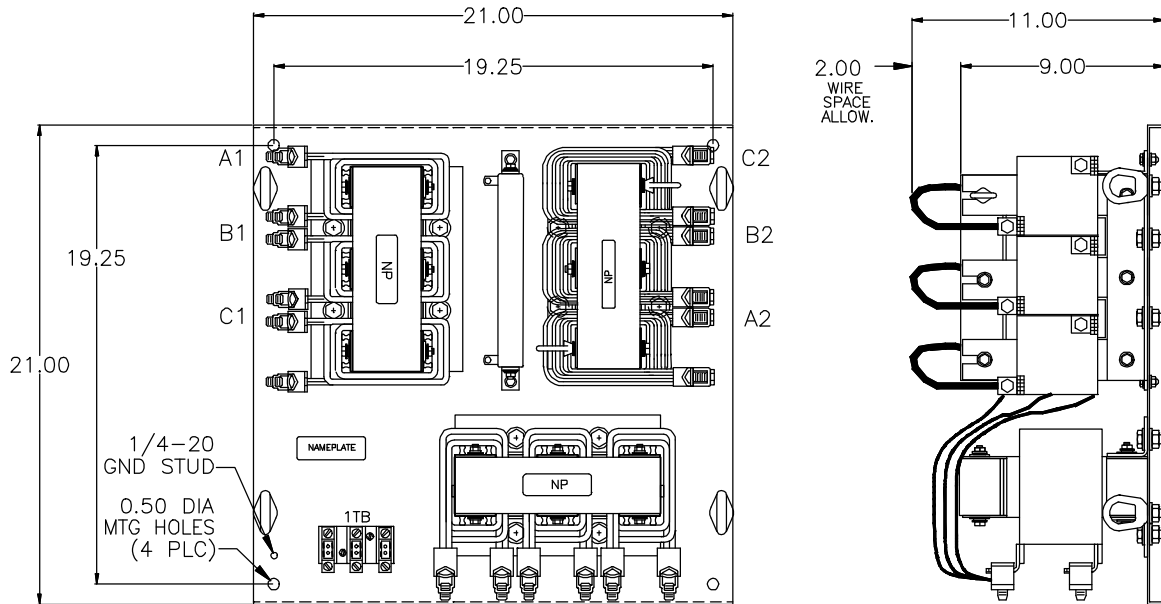

INSTALLATION INSTRUCTIONS – continued

Figure 8. 100 HP, 480 VAC Capacitor Assembly Outline Drawing

All dimensions are in inches

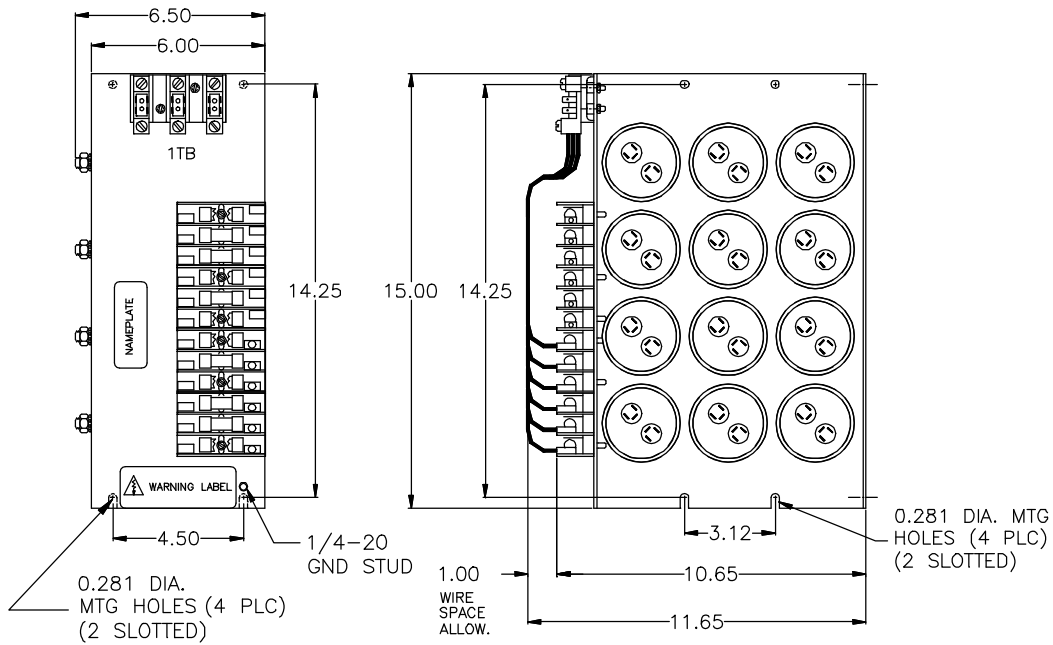

NOTE: TWO CAPACITOR ASSEMBLIES REQUIRED

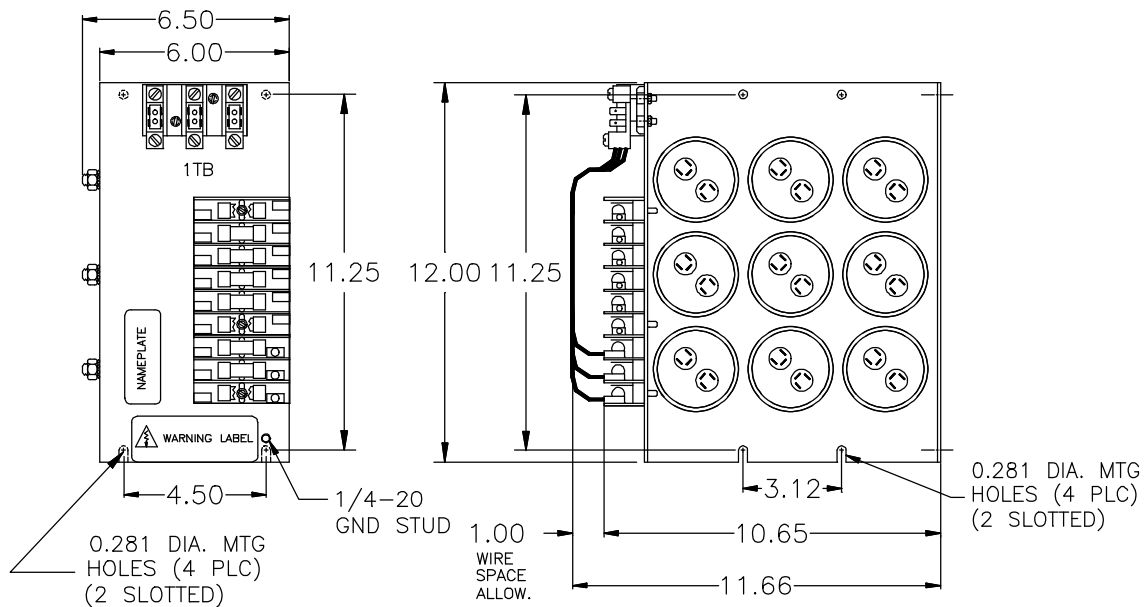

INSTALLATION INSTRUCTIONS – continued

Figure 9. 125 - 150 HP, 480 VAC Outline Drawing

All dimensions are in inches

REACTOR ASSEMBLY

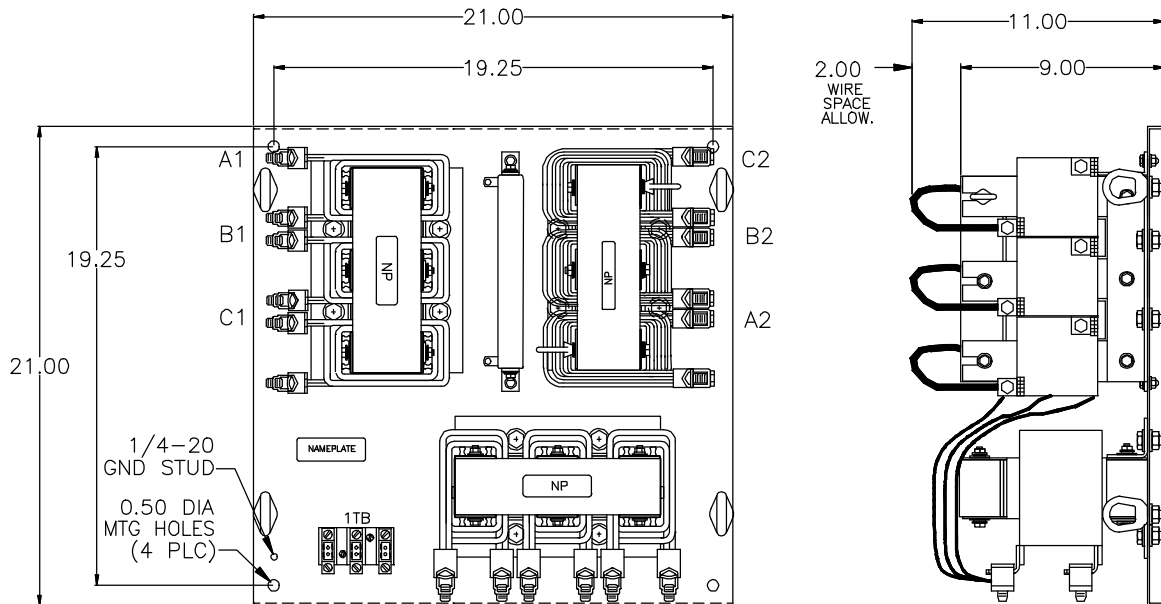

NOTE: SEE TABLE FOR NUMBER OF CAPACITOR ASSEMBLIES

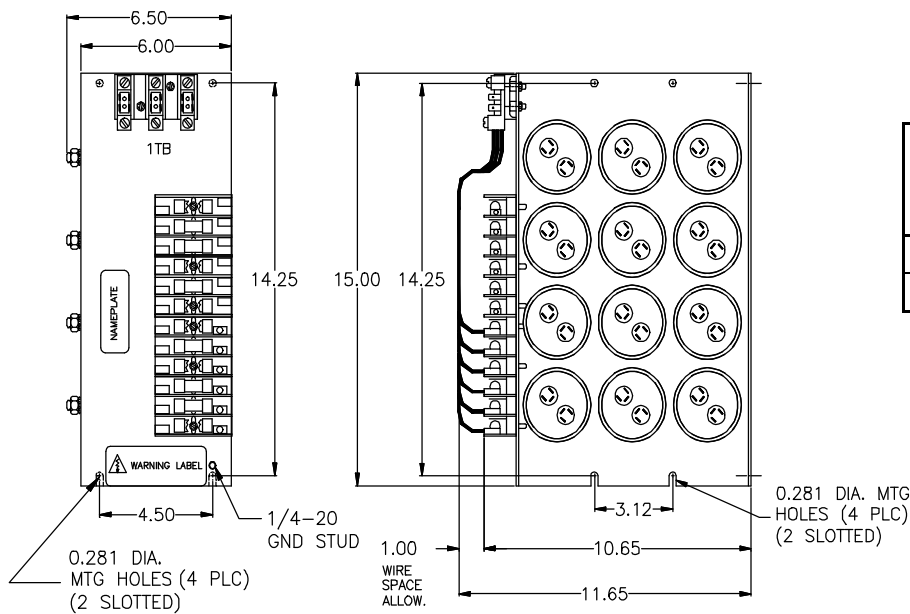

HP	NO. OF CAPACITOR PANELS
125	2
150	3

NOTE: CAPACITOR ASSEMBLY MAY BE MOUNTED IN EITHER PLANE

INSTALLATION INSTRUCTIONS – continued

Figure 10. 200 - 300 HP, 480 VAC Vertical Mounting Outline Drawing

All dimensions are in inches

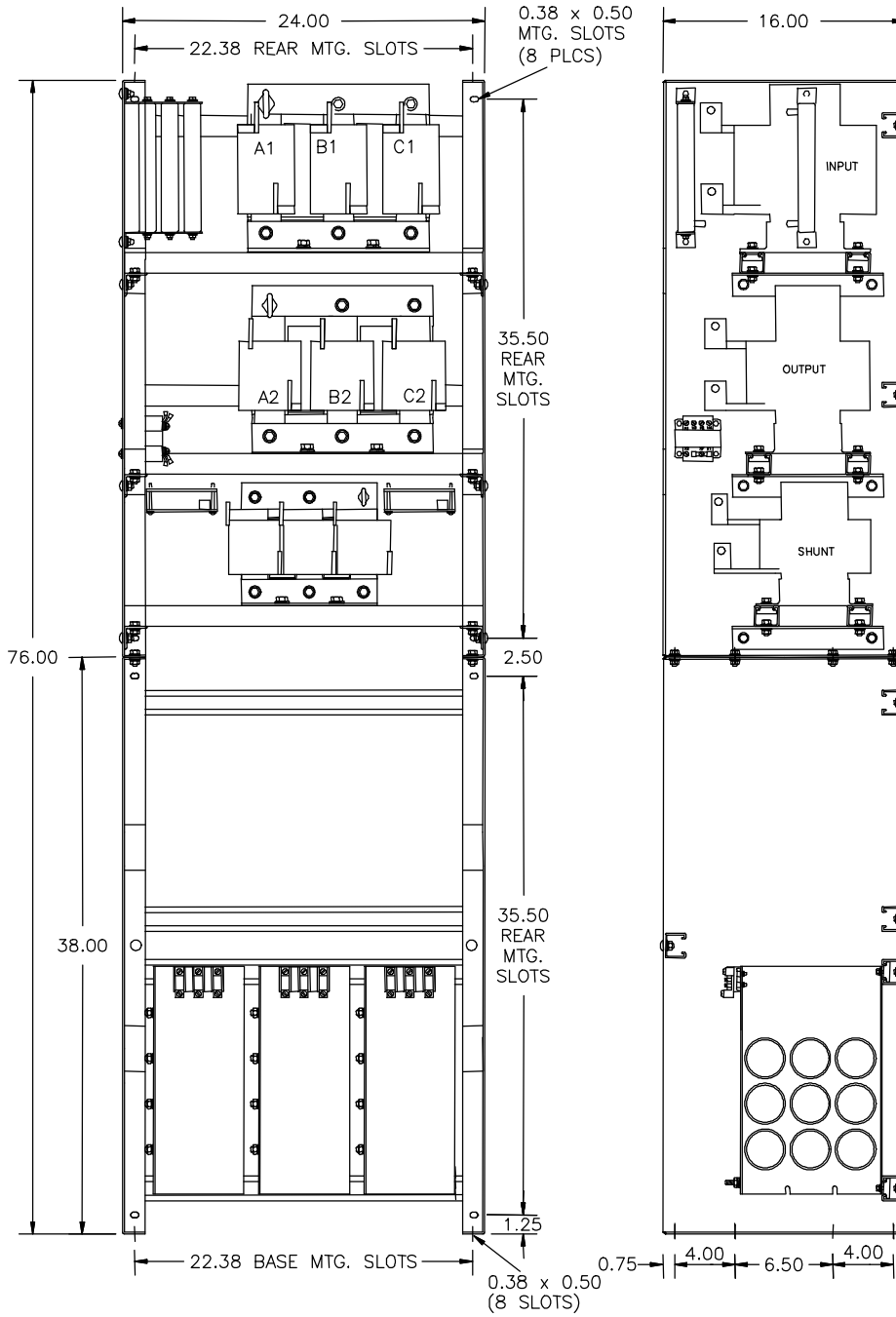

INSTALLATION INSTRUCTIONS – continued

Figure 11. 200 - 300 HP, 480 VAC Horizontal Mounting Outline Drawing

All dimensions are in inches

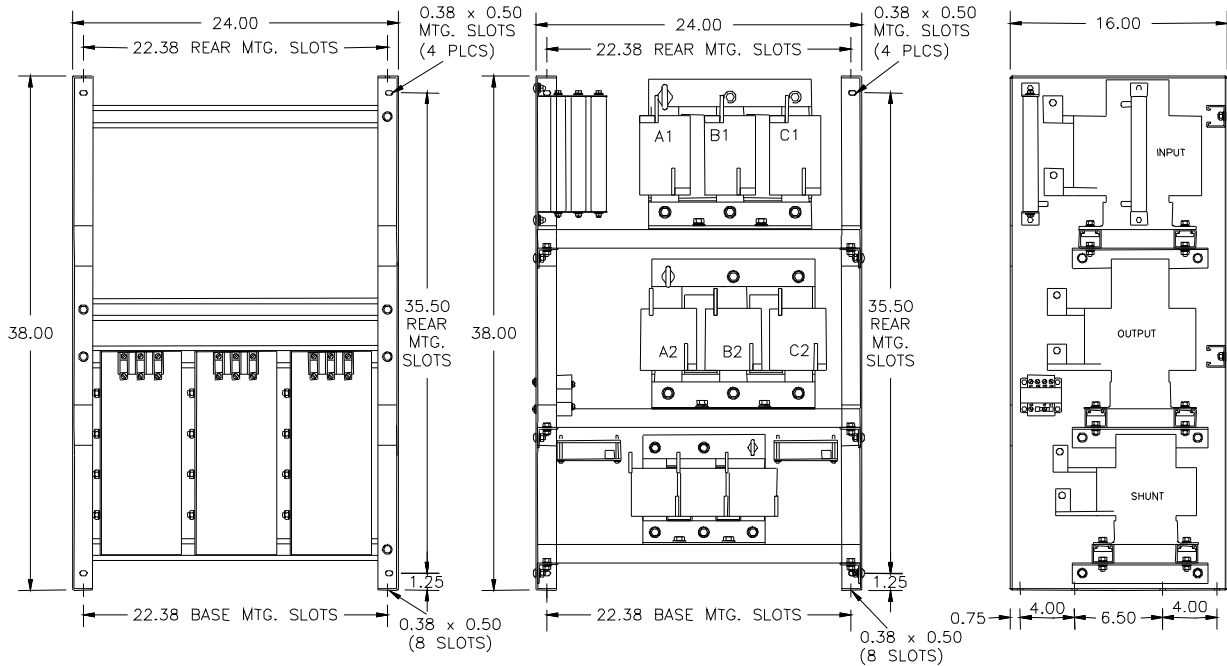

480 VAC Matrix Filters rated 200 HP through 300 HP, are constructed from a reactor assembly and a capacitor assembly. These assemblies are designed to be mounted vertically. The reactor assembly may be mounted above the capacitor assembly as shown in Figure 10 or the assemblies may be mounted separately as shown in Figure 11. The capacitor assembly should be located in the lowest temperature regions of the enclosure – generally toward the bottom.

The reactor and capacitor assemblies are shipped vertically oriented bolted and banded front-to-back to a common pallet.

INSTALLATION INSTRUCTIONS – continued

Figure 12. 3 – 15 HP Interconnection Diagram

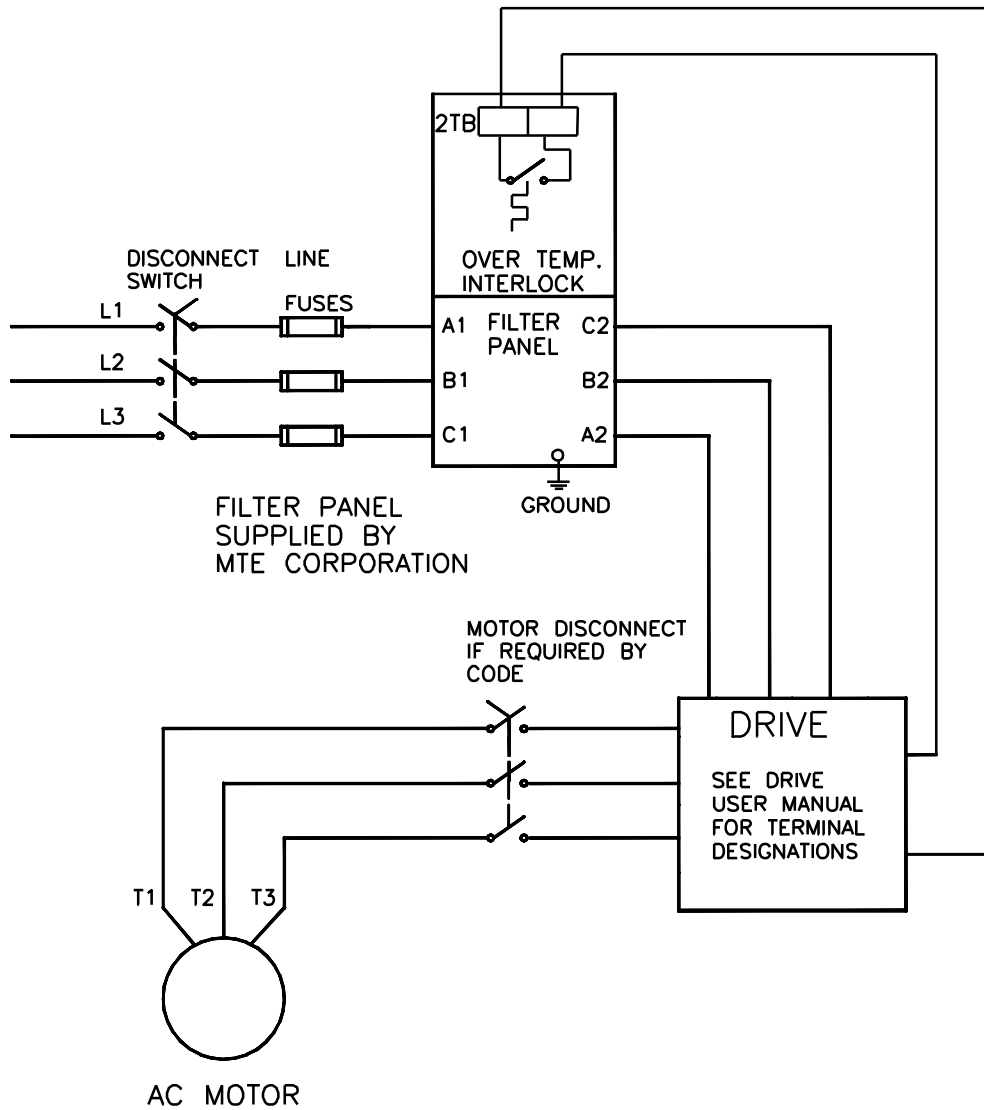

INSTALLATION INSTRUCTIONS – continued

Figure 13. 20 – 300 HP Interconnection Diagram

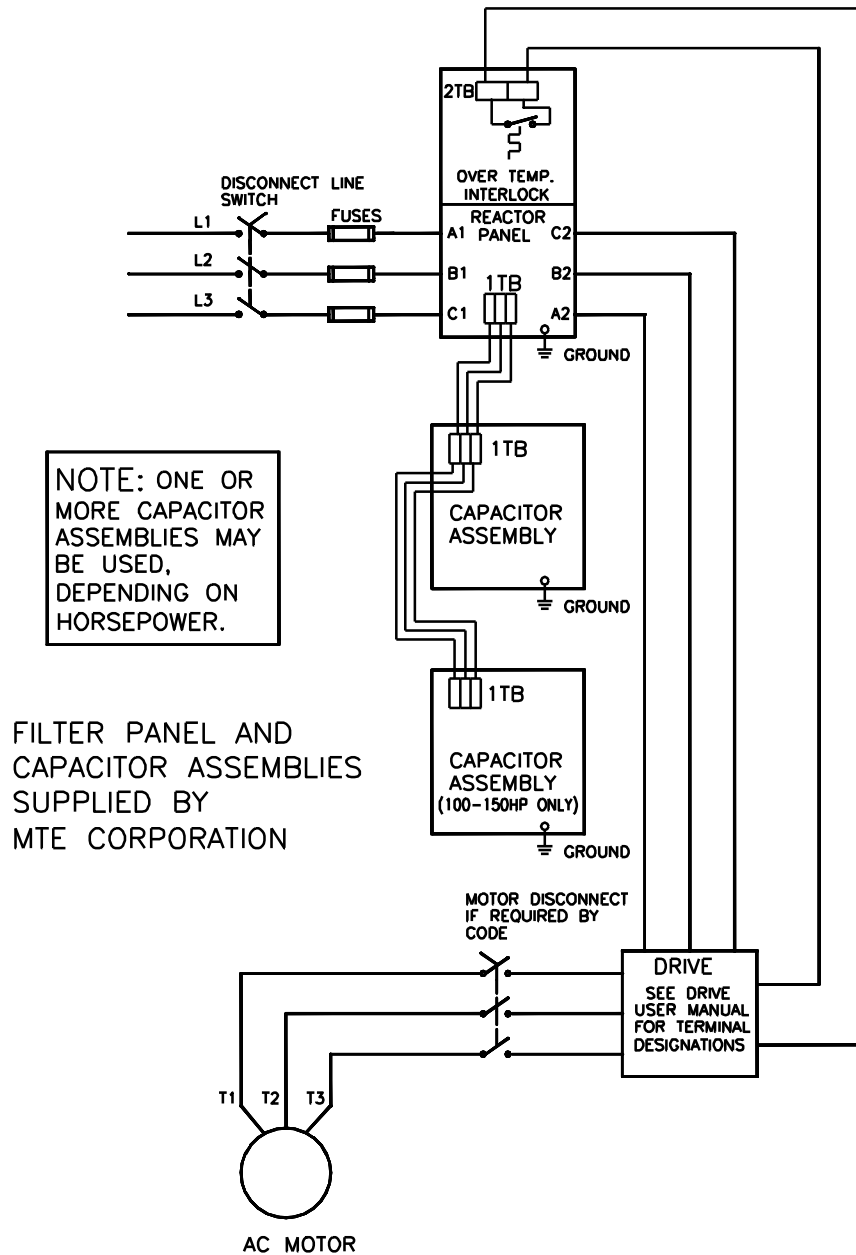

INSTALLATION INSTRUCTIONS – continued

Table 3. Capacitor Assembly Current Ratings

HP	Current Rating (Amps RMS)	HP	Current Rating (Amps RMS)
20	13	100	50
25	13	125	79
30	20	150	100
40	20	200	124
50	28	250	149
60	28	300	182
75	34		

Table 4. Capacitor Assembly Terminal Specifications

Filter Rating (HP)	Capacitor Terminals <i>NOTE: Two terminals per phase</i>	
	Wire Range (AWG)	Terminal Torque (in lbs)
20 – 150 HP	14 – 10	35
	8	40
	4 – 6	45
	1/0 – 3	50
200 – 300 HP	6-00	120

6. FILTER DESCRIPTION

The MTE Matrix Filter is a low pass filter containing proprietary technology which makes it particularly useful for harmonic mitigation of adjustable speed drives. Figure 14 shows a block diagram of the filter. Three phase AC power is connected to the input section which contains a three phase AC reactor and circuitry which inhibits oscillation of the filter with the AC power system. The center leg consists of a series reactor and capacitor bank. Because of the capacitor bank the filter operates with leading power factor at all loads, but unlike trap filters the MTE Matrix Filter does not produce significant voltage rise at the point of common coupling with the power system. The standard 12% filter output section consists of an AC output reactor.

The 8% filter is comprised of a standard 12% filter plus an additional output reactor.

Matrix filters are horsepower and current rated. Current ratings have been established on the basis of 115% of the NEC 480 VAC motor ratings. Because the filter operates at near unity power factor, a motor drive system fed by a Matrix Filter and operating at rated horsepower will draw significantly less current than the filters rated input current. For a drive system with a typical efficiency of .85 and a Matrix Filter with an efficiency of .98, the power into the filter is $(1/.98)(1/.85)(746)(\text{HP})$ where HP is

the motor horsepower rating. The filter input power is also equal to $(\sqrt{3})(\text{Line Current})(\text{Line to Line Voltage})$. Equating these two quantities and then calculating the line current as a percent of rated filter current for 10 HP, 100HP, and 300HP for 480 VAC results in the following data.

HP	Rated Filter Current %
10	67
100	75
300	78

Filter enclosures have been designed to accommodate filter power dissipation at rated horsepower. Filters mounted on open panels are designed to carry rated current.

Select a matrix filter to match the horsepower rating of the drive. For multiple drive applications, the horsepower rating of the filter should be equal to the total horsepower ratings of the drives. For example, select a 100 Hp filter to feed three 30Hp and one 10 Hp drives. Multiple drives fed from a single filter may be operated independently.

Because the filter supplies harmonic currents required by the drive, linear loads (such as space heaters, incandescent lighting and AC motors operated across the line) should not be connected to the output of the filter.

Figure 14. Block Diagram

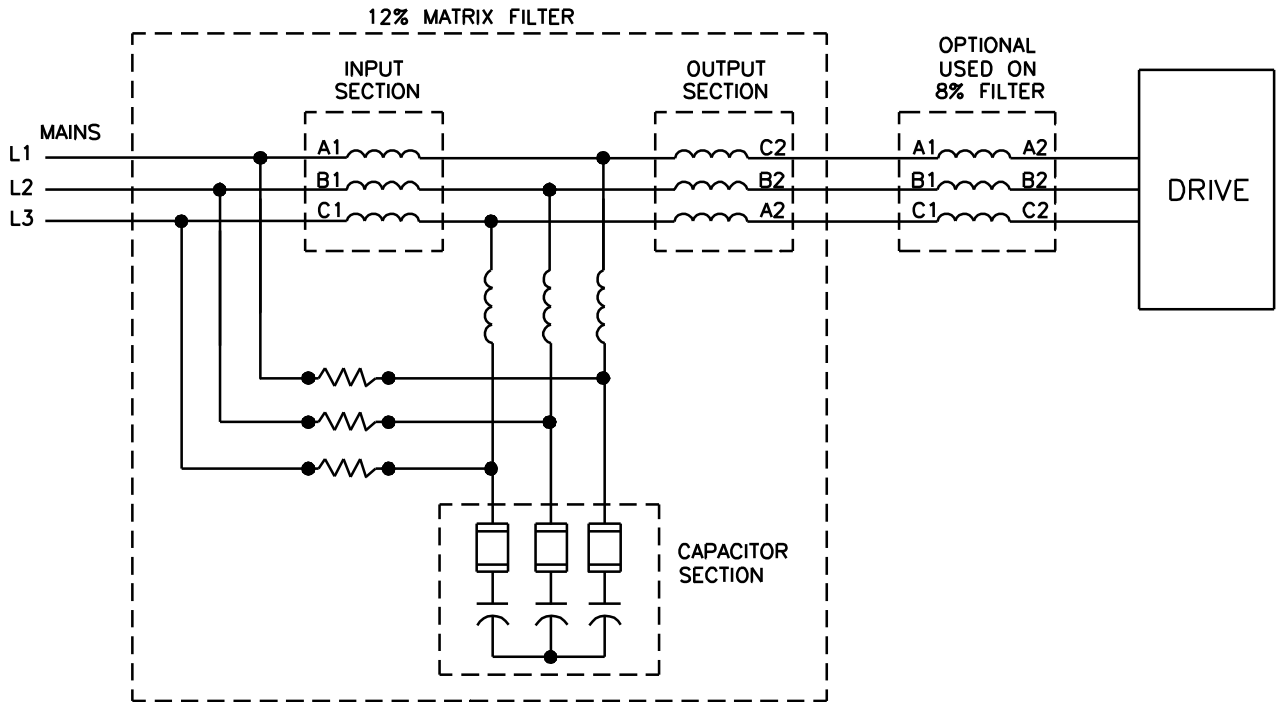

7. STARTUP

Safety Precautions

Before startup, observe the following warnings and instructions:

WARNING

Internal components of the filter are at line potential when the filter is connected to the utility. This voltage is extremely dangerous and may cause death or severe injury if you come in contact with it.

WARNING

After disconnecting the utility power, wait at least 5 minutes before doing any work on the filter connections. After removing power, allow at least five minutes to elapse and verify that the capacitors have discharged to a safe level before contacting internal components. Connect a DC voltmeter across the capacitor terminals 1, 2 and 3 on terminal block 1TB. Start with the meter on the highest scale and progressively switch to a lower scale as the indicated voltage falls below the maximum value of the scale used.

Sequence of Operation

1. Read and follow safety precautions.
2. After installation, ensure that:
 - All filter ground terminals are connected to ground.
 - Power wiring to the utility, drive and motor is in accordance with the installation and connection instructions in Chapter 5.

3. Check that moisture has not condensed on the filter components. If moisture is present, do not proceed with startup until the moisture has been removed.
4. Disconnect the filter output from the drive.
5. Connect the filter to the utility.

WARNING

Use extreme caution to avoid contact with line voltage when checking for power. INJURY OR DEATH MAY RESULT IF SAFETY PRECAUTIONS ARE NOT OBSERVED.

6. Confirm that line voltage is present at the input terminals (A1, B1, C1) of the filter.
7. Confirm that line voltage is present at the output terminals (A2, B2, C2) of the filter.
8. Disconnect the filter from the utility.
9. Connect the filter output to the drive.
10. Refer to the drive user manual for the drive startup procedure. Observe all safety instructions in the drive user manual.

WARNING

INJURY OR DEATH MAY RESULT IF THE DRIVE SAFETY PRECAUTIONS ARE NOT OBSERVED.

CAUTION

Damage to equipment may occur if the drive startup procedures are not observed.

8. TROUBLESHOOTING

WARNING

When properly installed, this equipment has been designed to provide maximum safety for operating personnel. However, hazardous voltages exist within the confines of the enclosure. Servicing should therefore be performed by qualified personnel only and in accordance with OSHA Regulations.

To aid in troubleshooting, a block diagram is shown in Figure 14, and a list of potential problems and solutions are listed below.

WARNING

High voltage is used in the operation of this filter. Use Extreme caution to avoid contact with high voltage when operating, installing or repairing this filter. **INJURY OR DEATH MAY RESULT IF SAFETY PRECAUTIONS ARE NOT OBSERVED.**

After removing power, allow at least five minutes to elapse and verify that the capacitors have discharged to a safe level before contacting internal components. Connect a DC voltmeter across the capacitor terminals 1, 2 and 3 on terminal block 1TB. Start with the meter on the highest scale and progressively switch to a lower scale as the indicated voltage falls below the maximum value of the scale used.

TROUBLESHOOTING - continued

PROBLEM:	Line voltage is not present at the filter output terminals.
Possible cause:	Power to the filter is turned off.
Solution:	Turn power on.
Possible cause:	One or more external line fuses are blown.
Solution:	Verify the continuity of line fuses in all phases. Replace as necessary.

PROBLEM:	Harmonic current distortion exceeds 12% on one or more input phases.
Possible cause:	One or more capacitor fuses have blown.
Solution:	Verify the continuity of capacitor fuses in all three phases. Replace as necessary.
Possible cause:	On filters rated 20HP and above, the capacitor assembly has not been connected.
Solution:	Check interconnection of capacitor assembly with reactor panel (Figure 13).
Possible cause:	A capacitor has failed.
Solution:	Inspect the tops of all capacitors for bowing. Replace failed capacitors. Also replace the fuse in series with the failed capacitor.
Possible cause:	Source impedance is less than 1.5%.
Solution:	Add a minimum 1.5% impedance line reactor to the filter input
Possible cause:	Input source voltage harmonic distortion.
Solution:	Identify equipment causing harmonic voltage distortion and add filters as required or accept elevated THVD
Possible cause:	Line voltage unbalance exceeds 1%.
Solution:	Balance input line voltage to 1% or less.

TROUBLESHOOTING - continued

PROBLEM:	Harmonic current distortion exceeds 8% on one or more phases.
Possible cause:	The output reactor required for an 8% filter was not installed. (See Figure 14.)
Solution:	Install the required output reactor.
Possible cause:	One or more capacitor fuses have blown.
Solution:	Verify the continuity of capacitor fuses in all three phases. Replace as necessary.
Possible cause:	On filters rated 20HP and above, the capacitor assembly has not been connected.
Solution:	Check interconnection of capacitor assembly with reactor panel (Figure 13).
Possible cause:	A capacitor has failed.
Solution:	Inspect the tops of all capacitors for bowing. Replace failed capacitors. Also replace the fuse in series with the failed capacitor.
Possible cause:	Source impedance is less than 1.5%.
Solution	Add a minimum 1.5% impedance line reactor to the filter input
Possible cause:	Input source voltage harmonic distortion.
Solution	Identify equipment causing harmonic voltage distortion and add filters as required or accept elevated THVD
Possible cause:	Line voltage unbalance exceeds 1%.
Solution:	Balance input line voltage to 1% or less.

TROUBLESHOOTING – continued

PROBLEM:	Filter output voltage is not within specification
Possible cause:	Filter input voltage is not within specification.
Solution:	Check the AC input line voltage and verify that it is within tolerance. Refer to the filter service conditions and performance specifications in Chapter 3 for tolerances.
Possible cause:	Source impedance is out of tolerance.
Solution:	Verify that the source impedance is within tolerance. Refer to the filter service conditions and performance specifications in Chapter 3 for tolerances.

Matrix Filter Series A User Manual
INSTR-002 Rel. 011018
ADDENDUM A

ENCLOSED 480V CURRENT RATING

HP	MAXIMUM AMPS
3	4.8
5	7.6
7.5	11
10	14
15	21
20	27
25	34
30	40
40	52
50	65
60	77
75	96
100	124
125	156
150	180
200	240
250	302
300	361