

MTE SERIES RLW

World REACTORS

USER MANUAL

PART NO. INSTR -030

REL. 090529

© 2009 MTE Corporation

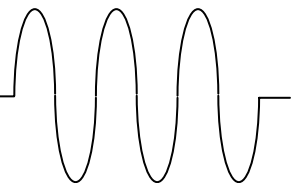

IMPORTANT USER INFORMATION

NOTICE

MTE Series RLW Line/Load Reactors are components designed to improve the reliability of adjustable frequency drives, DC drives and a wide variety of other types of power electronic equipment. In addition they provide input line current harmonic mitigation and long lead protection for inverter fed motors. MTE reactors are available in a large number of current ratings and a variety of inductance values. The suitability of a line/load reactor for a specific application must therefore be ultimately determined by the customer. In no event will MTE Corporation assume responsibility or liability for any direct or consequential damages resulting from the use or application of reactors. Nor will MTE Corporation assume patent liability with respect to the use of information, circuits or equipment described in this instruction manual.



Table of Contents

TABLE OF CONTENTS	2
1. IMPORTANT SAFETY INFORMATION WARNING.....	3
2. INTRODUCTION.....	4
MODEL CODE PART NUMBER CONFIGURATION.....	5
SPECIFICATION DATA	6
SERVICE FACTOR	6
AMBIENT TEMPERATURE.....	6
APPROVALS.....	6
ENCLOSURES:	6
DIN RAIL MOUNT.....	6
REACTOR ELECTRICAL DATA	8
SELECTION & APPLICATION GUIDE	10
RL REACTOR CROSS TO RLW	11
MECHANICAL DATA	12
OPEN PANEL	12
ENCLOSED REACTOR MECHANICAL.....	14
FACTORY CONFIGURED OPTIONS	15
KIT-0038.....	15
KIT-0039.....	15
KIT-0040.....	15
OUTLINE DRAWINGS	16
FIGURE 1 SNAP BASE MOUNT	16
FIGURE 2 35MM DIN MOUNT OPTION.....	16
FIGURE 3 STANDARD MOUNTING	16
FIGURE 4 CAB – 8.....	17
FIGURE 5 CAB 13V.....	17
FIGURE 6 CAB 12C.....	18
REACTOR INSTALLATION	19
POWER WIRING CONNECTION.....	20
GROUNDING.....	21
CONNECTION DIAGRAMS	22
STARTUP	23
SEQUENCE OF OPERATION.....	23

1. IMPORTANT SAFETY INFORMATION WARNING

ONLY A QUALIFIED ELECTRICIAN CAN CARRY OUT THE ELECTRICAL INSTALLATION OF LINE/LOAD REACTORS

WARNING

High voltage is used in the operation of line/load reactors. Use Extreme caution to avoid contact with high voltage when operating, installing or repairing equipment containing line/load reactors.

INJURY OR DEATH MAY RESULT IF SAFETY PRECAUTIONS ARE NOT OBSERVED.

Line/load reactors are used in conjunction with inverters, or other electrical equipment that may feedback lethal voltages. Follow the safety instructions in the equipment used with the reactor in addition to the safety instruction in this manual.

WARNING

The opening of the branch circuit protective device may be an indication that a fault current has been interrupted. To reduce the risk of fire or electrical shock, line/load reactors should be examined and replaced if damaged.

WARNING

An upstream disconnect/protection device must be used as required by the National Electrical Code (NEC).

WARNING

Even if the upstream disconnect/protection device is open, a drive or inverter down stream of the line/load reactor may feed back high voltage to the reactor. The inverter or drive safety instructions must be followed. ***INJURY OR DEATH MAY RESULT IF THE DRIVE SAFETY PRECAUTIONS ARE NOT OBSERVED.***

WARNING

The frame of line/load reactors must be grounded at least at one of the reactor's mounting holes.

WARNING

Only spare parts obtained from MTE Corporation or an authorized MTE distributor can be used

2. INTRODUCTION

This manual was specifically developed to assist in the installation, interconnection and operation of MTE Corporation Series RLW Line/Load Reactors

This manual is intended for use by personnel experienced in the operation and maintenance of electronic drives, inverters and similar types of power electronic equipment. Because of the high voltages required by the equipment connected to line/load reactors and the potential dangers presented by rotating machinery, it is essential that all personnel involved in the operation and maintenance of line/load reactors know and practice the necessary safety precautions for this type of equipment. Personnel should read and understand the instructions contained in this manual before installing, operating or servicing line/load reactors and the drive to which the reactor is connected.

Upon Receipt of a Reactor:

MTE Line/load Reactors have been subjected to demanding factory tests before shipment. Carefully inspect the shipping container for damage that may have occurred in transit. Then unpack the filter and carefully inspect for any signs of damage. Save the shipping container for future transport of the reactor.

In the event of damage, please contact and file a claim with the freight carrier involved immediately.

If the equipment is not going to be put into service upon receipt, cover and store the reactor in a clean, dry location. After storage, ensure that the equipment is dry and that no condensation has accumulated on the reactor before applying power.

Repair/Exchange Procedure

MTE Corporation requires a Returned Material Authorization Number before it can accept any reactors that qualify for return or repair. If problems or questions arise during installation, setup, or operation of the filter, please call us for assistance at:

Phone: 1-262-253-8200

FAX: 1-262-253-8222

Specification Data

Impedance basis	Calculation: $\% Z = (I/V) \times 2\pi fL\sqrt{3} \times 100$
Service Factor (continuous):	100%
Overload Rating <i>Line side</i>	150% of RMS rating for 1 minute 200% of RMS rating for 10 seconds
Maximum system voltage	690 Volts
Switching frequency	Maximum 20 KHz Minimum 1 KHz
Insulation system	200° C
Temperature rise	140 C (average)
Ambient temperature	Full load: -40 to 50° C Open -40 to 45° C Enclosed -40 to 90° C Storage
Altitude (maximum)	1000 meters
Fundamental frequency	50/60 Hz de-rate above 60 Hz
Inductance tolerance	+/- 10%
Inductance curve (typical)	100% at 100% current 80% at 150% current 50% at 200% current
Dielectric Strength	4000 volts RMS (2200 volts peak repetitive)
Max audible level at two meters:	Line applications: 65 dBa Load applications: 76 dBa
Approvals:	CE, UL-508, Type RL cUL per CSA C22.2
<i>Note: Short circuit rating not required under Exception No.1 of UL508A SB4.2.1 effective 4/25/06</i>	
Enclosures:	MTECab-8,13V,17V have NEMA1 Cab 12C and up are NEMA1rated as NEMA2 (Indoor rating with ripping water protection) MTE NEMA 3R is a type 3R outdoor rating
DIN Rail Mount:	2 spring steel screw mounts for 35mm rail With 10-32 screws

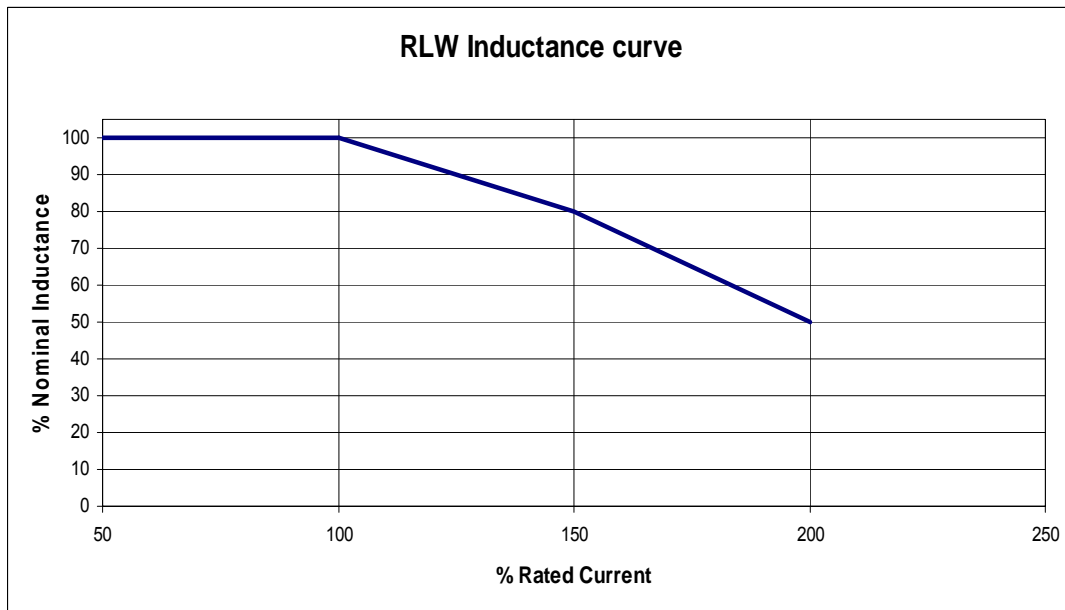
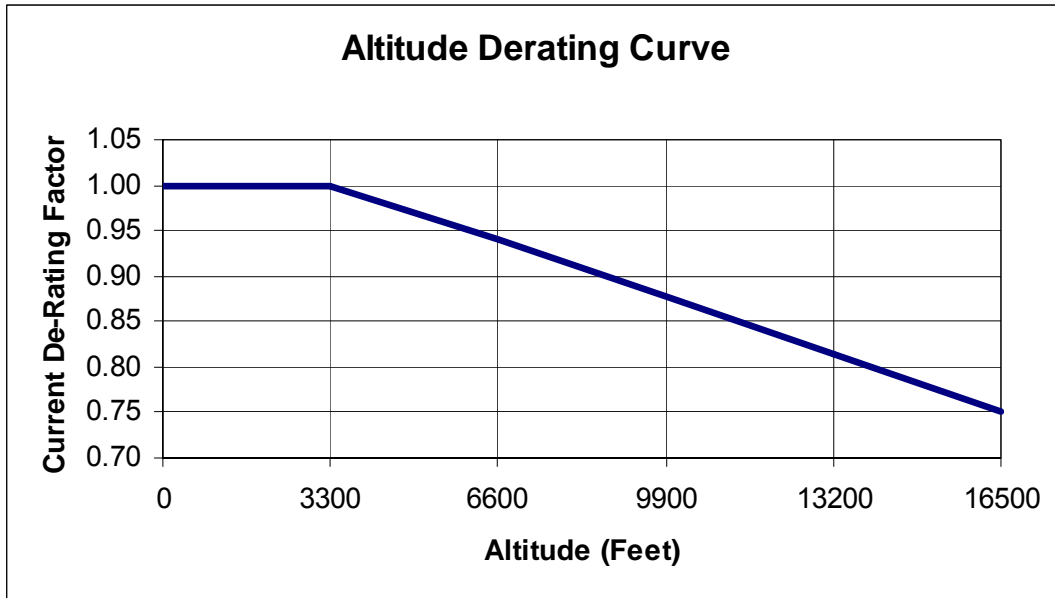

Reactor Electrical Data

RMS Amps	Open PN	NEMA 1	NEMA 3R	Inductance mH	Watts Loss
0.5	RLW-00P501	RLW-00P511	RLW-00P531	22	2.3
	RLW-00P503	RLW-00P513	RLW-00P533	46	3.6
	RLW-00P505	RLW-00P515	RLW-00P535	74	4.8
	RLW-00P506	RLW-00P516	RLW-00P536	92	5.4
0.75	RLW-0P7501	RLW-0P7511	RLW-0P7531	15	4.2
	RLW-0P7503	RLW-0P7513	RLW-0P7533	31	6.6
	RLW-0P7505	RLW-0P7515	RLW-0P7535	49	8.8
	RLW-0P7506	RLW-0P7516	RLW-0P7536	61	10.1
1.1	RLW-01P101	RLW-01P111	RLW-01P131	10	4.8
	RLW-01P103	RLW-01P113	RLW-01P133	21	7.8
	RLW-01P105	RLW-01P115	RLW-01P135	33	10.1
	RLW-01P106	RLW-01P116	RLW-01P136	42	11.9
1.6	RLW-01P601	RLW-01P611	RLW-01P631	6.9	6.9
	RLW-01P603	RLW-01P613	RLW-01P633	14	10.9
	RLW-01P605	RLW-01P615	RLW-01P635	23	15
	RLW-01P606	RLW-01P616	RLW-01P636	29	17.7
2.1	RLW-02P101	RLW-02P111	RLW-02P131	5.3	9
	RLW-02P103	RLW-02P113	RLW-02P133	11	14.3
	RLW-02P105	RLW-02P115	RLW-02P135	18	19.6
	RLW-02P106	RLW-02P116	RLW-02P136	22	22.3
3.4	RLW-03P401	RLW-03P411	RLW-03P431	3.2	12.3
	RLW-03P403	RLW-03P413	RLW-03P433	6.8	19.6
	RLW-03P405	RLW-03P415	RLW-03P435	11	26.5
	RLW-03P406	RLW-03P416	RLW-03P436	14	31.5
4.8	RLW-04P801	RLW-04P811	RLW-04P831	2.3	13.8
	RLW-04P803	RLW-04P813	RLW-04P833	4.8	23
	RLW-04P805	RLW-04P815	RLW-04P835	7.7	37.5
	RLW-04P806	RLW-04P816	RLW-04P836	10	40.1
7.6	RLW-07P601	RLW-07P611	RLW-07P631	1.5	19.2
	RLW-07P603	RLW-07P613	RLW-07P633	3	37.2
	RLW-07P605	RLW-07P615	RLW-07P635	4.8	47.8
	RLW-07P606	RLW-07P616	RLW-07P636	6	53.8
11	RLW-001101	RLW-001111	RLW-001131	1	26.8
	RLW-001103	RLW-001113	RLW-001133	2.1	40.9
	RLW-001105	RLW-001115	RLW-001135	3.3	54.4
	RLW-001106	RLW-001116	RLW-001136	4.3	59.1
14	RLW-001401	RLW-001411	RLW-001431	0.79	32.7
	RLW-001403	RLW-001413	RLW-001433	1.6	48.2
	RLW-001405	RLW-001415	RLW-001435	2.6	60.6
	RLW-001406	RLW-001416	RLW-001436	3.3	66
21	RLW-002101	RLW-002111	RLW-002131	0.53	38.3
	RLW-002103	RLW-002113	RLW-002133	1.1	57.4
	RLW-002105	RLW-002115	RLW-002135	1.8	73.5
	RLW-002106	RLW-002116	RLW-002136	2.2	78
28	RLW-002801	RLW-002811	RLW-002831	0.39	48.2
	RLW-002803	RLW-002813	RLW-002833	0.82	66.8
	RLW-002805	RLW-002815	RLW-002835	1.3	93.8
	RLW-002806	RLW-002816	RLW-002836	1.6	110.6

Amps	Open PN	NEMA 1	NEMA 3R	Inductance mH	Watts Loss
35	RLW-003501	RLW-003511	RLW-003531	0.35	68
	RLW-003503	RLW-003513	RLW-003533	0.71	102
	RLW-003505	RLW-003515	RLW-003535	1.2	121
46	RLW-004601	RLW-004611	RLW-004631	0.3	77
	RLW-004603	RLW-004613	RLW-004633	0.55	99
	RLW-004605	RLW-004615	RLW-004635	0.98	179
55	RLW-005501	RLW-005511	RLW-005531	0.27	67
	RLW-005503	RLW-005513	RLW-005533	0.48	109
	RLW-005505	RLW-005515	RLW-005535	0.75	149
65	RLW-006501	RLW-006511	RLW-006531	0.19	87
	RLW-006503	RLW-006513	RLW-006533	0.38	105
	RLW-006505	RLW-006515	RLW-006535	0.64	214
83	RLW-008301	RLW-008311	RLW-008331	0.17	119
	RLW-008303	RLW-008313	RLW-008333	0.29	155
	RLW-008305	RLW-008315	RLW-008335	0.51	191
104	RLW-010401	RLW-010411	RLW-010431	0.12	
	RLW-010403	RLW-010413	RLW-010433	0.23	
	RLW-010405	RLW-010415	RLW-010435	0.375	
130	RLW-013001	RLW-013011	RLW-013031	0.095	
	RLW-013003	RLW-013013	RLW-013033	0.18	
	RLW-013005	RLW-013015	RLW-013035	0.3	
160	RLW-016001	RLW-016011	RLW-016031	0.08	
	RLW-016003	RLW-016013	RLW-016033	0.155	
	RLW-016005	RLW-016015	RLW-016035	0.26	
200	RLW-020001	RLW-020011	RLW-020031	0.06	
	RLW-020003	RLW-020013	RLW-020033	0.115	
	RLW-020005	RLW-020015	RLW-020035	0.195	
250	RLW-025001	RLW-025011	RLW-025031	0.05	
	RLW-025003	RLW-025013	RLW-025033	0.095	
	RLW-025005	RLW-025015	RLW-025035	0.155	
330	RLW-033001	RLW-033011	RLW-033031	0.04	
	RLW-033003	RLW-033013	RLW-033033	0.075	
	RLW-033005	RLW-033015	RLW-033035	0.125	
420	RLW-042001	RLW-042011	RLW-042031	0.03	
	RLW-042003	RLW-042013	RLW-042033	0.06	
	RLW-042005	RLW-042015	RLW-042035	0.105	
502	RLW-050201	RLW-050211	RLW-050231	0.025	
	RLW-050203	RLW-050213	RLW-050233	0.05	
	RLW-050205	RLW-050215	RLW-050235	0.085	
600	RLW-060001	RLW-060011	RLW-060031	0.02	
	RLW-060003	RLW-060013	RLW-060033	0.04	
	RLW-060005	RLW-060015	RLW-060035	0.065	
750	RLW-075001	RLW-075011	RLW-075031	0.015	
	RLW-075003	RLW-075013	RLW-075033	0.03	
	RLW-075005	RLW-075015	RLW-075035	0.05	

Selection & Application Guide

The MTE World reactor (RLW) is an international product that is a low cost line side alternative to the present line of MTE “RL” line/ load reactors. RLW’s are RMS current rated impedance devices. Selection is based on the choice of inductance correlated to the application motor full load amps, voltage and frequency and the number of phases. Use the selection table based on input voltage and RMS load current to identify corresponding reactor percent impedances. You may also pick from the NEC FLA motor selection table for common voltages. For critical impedance selection based on specific HP or load currents consult MTE applications engineering.

Single phase applications: The RLW like RL reactors may also be sized to protect single phase drives. Please see MTE application **AN0120** for details

For load side applications reactor current must be de-rated to 70% of the reactors nominal current rating.

Choose the impedance level:

- 1.5% Minimum impedance for reduction of low level voltage transients. RLW reactors may be used as a supplement to already installed reactors.
- 3% Helps minimize (95%) most drive nuisance tripping and faults caused by over voltage and input line disturbances.
- 5% The MTE recommended value to protect drive components from transient over-voltage prevents (99.9%) nuisance trips and offers limited harmonic protection to input line power from drive induced harmonics.

RL Reactor cross to RLW

Amps	RL Part No.	RLW Input PN	RLW Output PN	Amps	RL Part No.	RLW Input PN	RLW Output PN
1	<i>RL-00101</i>	RLW-00P506	RLW-01P606	80	<i>RL-08001</i>	RLW-008301	RLW-013003
	<i>RL-00102</i>	RLW-01P106	RLW-01P606		<i>RL-08002</i>	RLW-008305	RLW-013005
	<i>RL-00103</i>	RLW-01P105	RLW-01P606		<i>RL-08003</i>	RLW-008305	RLW-013005
	<i>RL-00104</i>	RLW-01P103	RLW-01P603		<i>RL-10001</i>	RLW-010401	RLW-016003
2	<i>RL-00201</i>	RLW-02P103	RLW-03P405	100	<i>RL-10002</i>	RLW-010403	RLW-016005
	<i>RL-00202</i>	RLW-02P105	RLW-03P406		<i>RL-10003</i>	RLW-010405	RLW-016005
	<i>RL-00203</i>	RLW-02P106	RLW-03P406		<i>RL-13001</i>	RLW-013001	RLW-020003
	<i>RL-00204</i>	RLW-02P101	RLW-03P403		<i>RL-13002</i>	RLW-013003	RLW-020005
4	<i>RL-00401</i>	RLW-04P801	RLW-07P603	130	<i>RL-13003</i>	RLW-013005	RLW-020005
	<i>RL-00402</i>	RLW-04P805	RLW-07P606		<i>RL-16001</i>	RLW-016001	RLW-025003
	<i>RL-00403</i>	RLW-04P806	RLW-07P606		<i>RL-16002</i>	RLW-016003	RLW-025005
	<i>RL-00404</i>	RLW-04P806	RLW-07P606		<i>RL-16003</i>	RLW-016005	RLW-025005
8	<i>RL-00801</i>	RLW-07P601	RLW-001403	160	<i>RL-20001B14</i>	RLW-020001	RLW-033001
	<i>RL-00802</i>	RLW-07P603	RLW-001406		<i>RL-20002B14</i>	RLW-020003	RLW-033005
	<i>RL-00803</i>	RLW-07P605	RLW-001406		<i>RL-20003B14</i>	RLW-020005	RLW-033005
	<i>RL-00804</i>	RLW-07P606	RLW-001406		<i>RL-25001B14</i>	RLW-025001	RLW-042001
12	<i>RL-01201</i>	RLW-001101	RLW-002103	200	<i>RL-25002B14</i>	RLW-025003	RLW-042005
	<i>RL-01202</i>	RLW-001103	RLW-002106		<i>RL-25003B14</i>	RLW-025005	RLW-042005
	<i>RL-01203</i>	RLW-001106	RLW-002106		<i>RL-32001B14</i>	RLW-033001	RLW-050203
	<i>RL-01801</i>	RLW-001401	RLW-002803		<i>RL-32002B14</i>	RLW-033003	RLW-050205
18	<i>RL-01802</i>	RLW-001403	RLW-002806	250	<i>RL-32003B14</i>	RLW-033005	RLW-050205
	<i>RL-01803</i>	RLW-001405	RLW-002806		<i>RL-40001B14</i>	RLW-042001	RLW-060001
	<i>RL-02501</i>	RLW-002101	RLW-003501		<i>RL-40002B14</i>	RLW-042003	RLW-060005
25	<i>RL-02502</i>	RLW-002103	RLW-003505	320	<i>RL-40003B14</i>	RLW-042005	RLW-060005
	<i>RL-02503</i>	RLW-002105	RLW-003505		<i>RL-50001B14</i>	RLW-050201	RLW-075003
	<i>RL-03501</i>	RLW-003501	RLW-005503		<i>RL-50002</i>	RLW-050203	RLW-075005
35	<i>RL-03502</i>	RLW-003503	RLW-005505	400	<i>RL-50003</i>	RLW-050205	RLW-075005
	<i>RL-03503</i>	RLW-003505	RLW-005505		<i>RL-60001</i>	RLW-060001	
	<i>RL-04501</i>	RLW-004601	RLW-006503		<i>RL-60002</i>	RLW-060003	
45	<i>RL-04502</i>	RLW-004603	RLW-006505	500	<i>RL-60003</i>	RLW-060005	
	<i>RL-04503</i>	RLW-004605	RLW-006505		<i>RL-75001</i>	RLW-075001	
	<i>RL-05501</i>	RLW-005501	RLW-008303		<i>RL-75002</i>	RLW-075003	
55	<i>RL-05502</i>	RLW-005503	RLW-008305	600	<i>RL-75003</i>	RLW-075005	
	<i>RL-05503</i>	RLW-005505	RLW-008305				

Note:

1. The RLW was designed to support global IEC and NEC input VFD drive motor applications. To gain optimum performance and size advantages use the RLW selections tables by HP and voltage in PB-1101.

2. RLW output selection is based on 70% of fundamental RLW current capacity for output load applications!

* **Open style reactor**, other part numbers are **NEMA 1-2** and **3R** enclosed units.

Mechanical Data

Open Panel

RMS Amps	Open Part Number			Dimension in inches					
	Open PN	Wt	Fig	A	B	C	D	E	F
0.5	RLW-00P501	1.5	1 - 2	4.5	3.7	1.5	0.0	4.0	-
	RLW-00P503	1.5	1 - 2	4.5	3.7	1.5	0.0	4.0	-
	RLW-00P505	1.6	1 - 2	4.5	3.7	1.5	0.0	4.0	-
	RLW-00P506	1.6	1 - 2	4.5	3.7	1.5	0.0	4.0	-
0.75	RLW-0P7501	1.4	1 - 2	4.5	3.7	1.5	0.0	4.0	-
	RLW-0P7503	1.5	1 - 2	4.5	3.7	1.5	0.0	4.0	-
	RLW-0P7505	1.5	1 - 2	4.5	3.7	1.5	0.0	4.0	-
	RLW-0P7506	1.6	1 - 2	4.5	3.7	1.5	0.0	4.0	-
1.1	RLW-01P101	1.5	1 - 2	4.5	3.7	1.5	0.0	4.0	-
	RLW-01P103	1.6	1 - 2	4.5	3.7	1.5	0.0	4.0	-
	RLW-01P105	1.6	1 - 2	4.5	3.7	1.5	0.0	4.0	-
	RLW-01P106	1.7	1 - 2	4.5	3.7	1.5	0.0	4.0	-
1.6	RLW-01P601	1.5	1 - 2	4.5	3.7	1.5	0.0	4.0	-
	RLW-01P603	1.6	1 - 2	4.5	3.7	1.5	0.0	4.0	-
	RLW-01P605	1.6	1 - 2	4.5	3.7	1.5	0.0	4.0	-
	RLW-01P606	1.7	1 - 2	4.5	3.7	1.5	0.0	4.0	-
2.1	RLW-02P101	1.5	1 - 2	4.5	3.7	1.5	0.0	4.0	-
	RLW-02P103	1.6	1 - 2	4.5	3.7	1.5	0.0	4.0	-
	RLW-02P105	1.7	1 - 2	4.5	3.7	1.5	0.0	4.0	-
	RLW-02P106	1.7	1 - 2	4.5	3.7	1.5	0.0	4.0	-
3.4	RLW-03P401	1.6	1 - 2	4.5	3.7	1.5	0.0	4.0	-
	RLW-03P403	1.6	1 - 2	4.5	3.7	1.5	0.0	4.0	-
	RLW-03P405	2.7	3	4.4	5	2.8	2.0	1.4	-
	RLW-03P406	2.8	3	4.4	5	2.8	2.0	1.4	-
4.8	RLW-04P801	1.7	1 - 2	4.5	3.7	1.5	0.0	4.0	-
	RLW-04P803	1.8	1 - 2	4.5	3.7	1.5	0.0	4.0	-
	RLW-04P805	2.8	3	4.4	5	2.8	2.0	1.4	-
	RLW-04P806	4.0	3	4.4	5	3.1	2.1	1.4	-
7.6	RLW-07P601	1.8	1 - 2	4.5	3.7	1.5	0.0	4.0	-
	RLW-07P603	2.8	3	4.4	5	2.8	2.0	1.4	-
	RLW-07P605	4.1	3	4.4	5	3.1	2.1	1.4	-
	RLW-07P606	4.2	3	4.4	5	3.1	2.1	1.4	-
11	RLW-001101	2.7	3	4.4	5	2.8	2.0	1.4	-
	RLW-001103	4.2	3	4.4	5	3.1	2.1	1.4	-
	RLW-001105	5.3	3	4.4	5	3.5	2.6	1.4	-
	RLW-001106	7.1	3	6	5.8	2.9	2.1	2.0	-
14	RLW-001401	2.8	3	4.4	5.3	2.8	2.0	1.4	-
	RLW-001403	4.3	3	4.4	5	3.1	2.1	1.4	-
	RLW-001405	7.1	3	6	5.8	2.9	2.1	2.0	-
	RLW-001406	9.4	3	6	5.8	3.3	2.5	2.0	-
21	RLW-002101	4.2	3	4.4	5.3	3.3	2.4	1.4	-
	RLW-002103	7.2	3	6	6.1	2.9	2.1	2.0	-
	RLW-002105	10.0	3	6	6.1	3.3	2.5	2.0	-
	RLW-002106	13.3	3	7.2	7	3.8	2.3	3.0	-
28	RLW-002801	5.1	3	4.4	5.3	3.5	2.6	1.4	-
	RLW-002803	9.5	3	6	6.1	3.3	2.5	2.0	-
	RLW-002805	10.4	3	6	6.1	3.3	2.3	2.0	-
	RLW-002806	14.3	3	7.2	7	3.8	2.3	3.0	-

Open Panel Mechanical cont.

RMS Amps	Open Part Number			Dimension in inches					
	Open PN	Wt	Fig	A	B	C	D	E	F
35	RLW-003501	10	3	6.0	6.0	3.5	2.73	2.0	3.0
	RLW-003503	13	3	7.2	6.0	3.75	2.25	3.0	-
	RLW-003505	18	3	7.2	6.0	4.3	2.75	3.0	-
46	RLW-004601	13	3	7.2	6.0	3.75	2.25	3.0	-
	RLW-004603	17	3	7.2	6.0	4.3	2.75	3.0	-
	RLW-004605	24	3	9	8.3	4.8	3.24	3.0	4.26
55	RLW-005501	18	3	7.2	6.0	4.0	2.75	3.0	-
	RLW-005503	20	3	7.2	6.0	4.25	2.75	3.0	-
	RLW-005505	26	3	9.0	7.0	6.5	3.24	3.0	4.26
65	RLW-006501	18	3	7.2	6.0	4.0	4.25	3.0	-
	RLW-006503	22	3	7.2	6.0	4.25	2.75	3.0	-
	RLW-006505	26	3	9.0	7.0	6.5	3.24	3.0	4.26
83	RLW-008301	19	3	7.2	6.0	4.25	2.75	3.0	-
	RLW-008303	26	3	9.0	7.0	6.5	3.24	3.0	4.26
	RLW-008305	35	3	9.0	7.0	6.75	3.74	3.0	4.26
104	RLW-010401								
	RLW-010403								
	RLW-010405								
130	RLW-013001								
	RLW-013003								
	RLW-013005								
160	RLW-016001								
	RLW-016003								
	RLW-016005								
200	RLW-020001								
	RLW-020003								
	RLW-020005								
200	RLW-025001								
	RLW-025003								
	RLW-025005								
330	RLW-033001								
	RLW-033003								
	RLW-033005								
420	RLW-042001								
	RLW-042003								
	RLW-042005								
502	RLW-050201								
	RLW-050203								
	RLW-050205								
600	RLW-060001								
	RLW-060003								
	RLW-060005								
750	RLW-075001								
	RLW-075003								
	RLW-075005								

Enclosed Reactor Mechanical

RMS Amps	NEMA 1			NEMA 3R		
	Part number	Wt	Fig	Part Number	Wt	Fig
0.5	RLW-00P511	8.5	4	RLW-00P531	76.5	6
	RLW-00P513	8.5	4	RLW-00P533	76.5	6
	RLW-00P515	8.6	4	RLW-00P535	76.6	6
	RLW-00P516	8.6	4	RLW-00P536	76.6	6
0.75	RLW-0P7511	8.4	4	RLW-0P7531	76.4	6
	RLW-0P7513	8.5	4	RLW-0P7533	76.5	6
	RLW-0P7515	8.5	4	RLW-0P7535	76.5	6
	RLW-0P7516	8.6	4	RLW-0P7536	76.6	6
1.1	RLW-01P111	8.5	4	RLW-01P131	76.5	6
	RLW-01P113	8.6	4	RLW-01P133	76.6	6
	RLW-01P115	8.6	4	RLW-01P135	76.6	6
	RLW-01P116	8.7	4	RLW-01P136	76.7	6
1.6	RLW-01P611	8.5	4	RLW-01P631	76.5	6
	RLW-01P613	8.6	4	RLW-01P633	76.6	6
	RLW-01P615	8.6	4	RLW-01P635	76.6	6
	RLW-01P616	8.7	4	RLW-01P636	76.7	6
2.1	RLW-02P111	8.5	4	RLW-02P131	76.5	6
	RLW-02P113	8.6	4	RLW-02P133	76.6	6
	RLW-02P115	8.7	4	RLW-02P135	76.7	6
	RLW-02P116	8.7	4	RLW-02P136	76.7	6
3.4	RLW-03P411	8.6	4	RLW-03P431	76.6	6
	RLW-03P413	8.7	4	RLW-03P433	76.7	6
	RLW-03P415	9.7	4	RLW-03P435	77.7	6
	RLW-03P416	20.8	5	RLW-03P436	77.8	6
4.8	RLW-04P811	8.7	4	RLW-04P831	76.7	6
	RLW-04P813	8.8	4	RLW-04P833	76.8	6
	RLW-04P815	20.7	5	RLW-04P835	77.7	6
	RLW-04P816	22.0	5	RLW-04P836	79.0	6
7.6	RLW-07P611	8.8	4	RLW-07P631	76.8	6
	RLW-07P613	20.7	5	RLW-07P633	77.7	6
	RLW-07P615	22.1	5	RLW-07P635	79.1	6
	RLW-07P616	22.2	5	RLW-07P636	79.2	6
11	RLW-001111	20.7	5	RLW-001131	77.7	6
	RLW-001113	22.2	5	RLW-001133	79.2	6
	RLW-001115	23.2	5	RLW-001135	80.2	6
	RLW-001116	25.1	5	RLW-001136	82.1	6
14	RLW-001411	20.8	5	RLW-001431	77.8	6
	RLW-001413	22.3	5	RLW-001433	79.3	6
	RLW-001415	25.1	5	RLW-001435	82.1	6
	RLW-001416	27.4	5	RLW-001436	84.4	6
21	RLW-002111	22.2	5	RLW-002131	79.2	6
	RLW-002113	25.2	5	RLW-002133	82.2	6
	RLW-002115	28.0	5	RLW-002135	85.0	6
	RLW-002116	31.3	5	RLW-002136	88.3	6
28	RLW-002811	23.1	5	RLW-002831	80.1	6
	RLW-002813	27.5	5	RLW-002833	84.5	6
	RLW-002815	31.7	5	RLW-002835	88.7	6
	RLW-002816	32.3	5	RLW-002836	89.3	6

Factory Configured Options

KIT-0038

DIN rail Mount.

A DIN rail mounting option is provided to utilize standard panel mounted DIN rail for securing the reactor via two steel mounting clips. Please see figure 2 for details

KIT-0039

RL base mount converter plate.

The base plate adaptor option will allow the RLW to use existing RL bolt hole mounting patterns.

KIT-0040

Vibration pads for enclosure mounting.

Vibration isolation for enclosed reactors may be fitted with an optional vibration pad to dampen cabinet vibrations from the reactor.

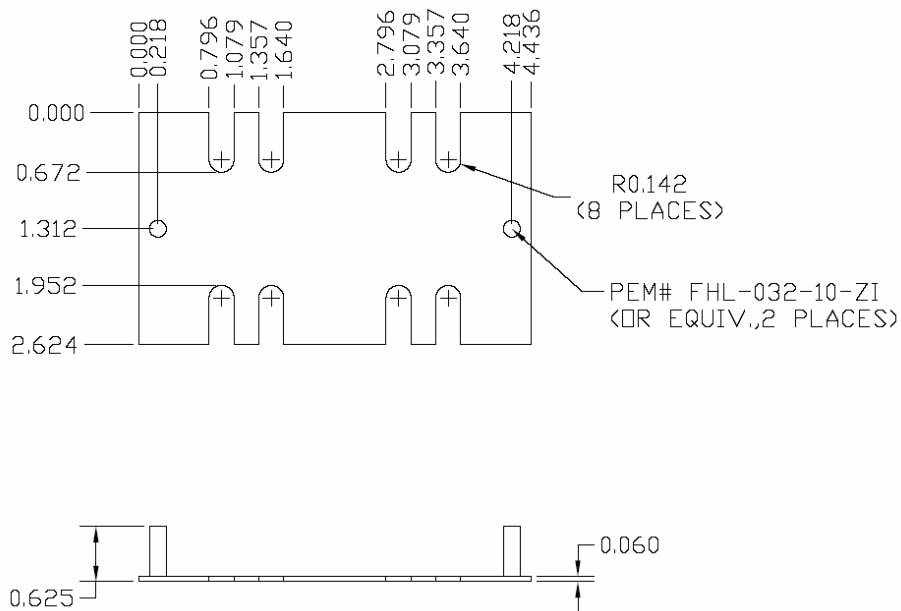

KIT -0039 converter plate

Outline Drawings

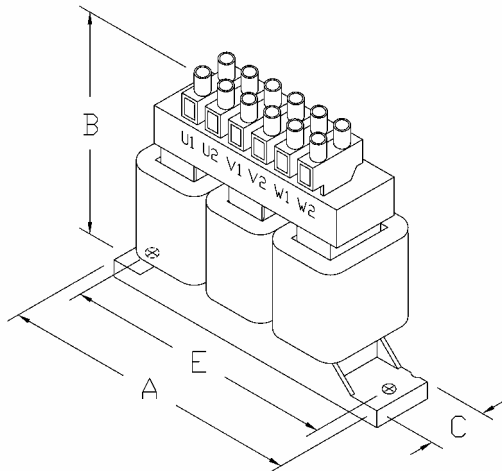

Figure 1 Snap Base Mount

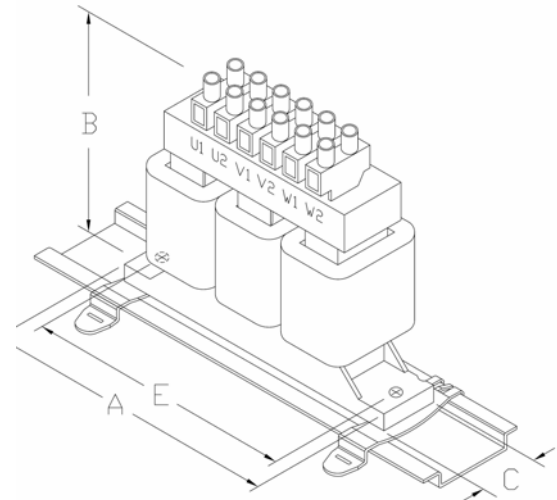

Figure 2 35mm DIN Mount option

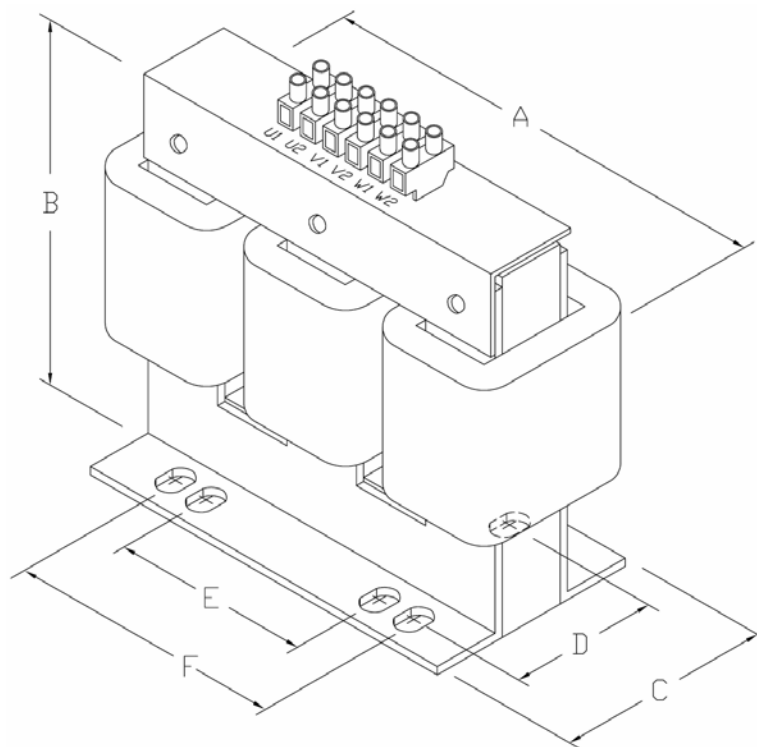

Figure 3 Standard Mounting

Outline Drawings

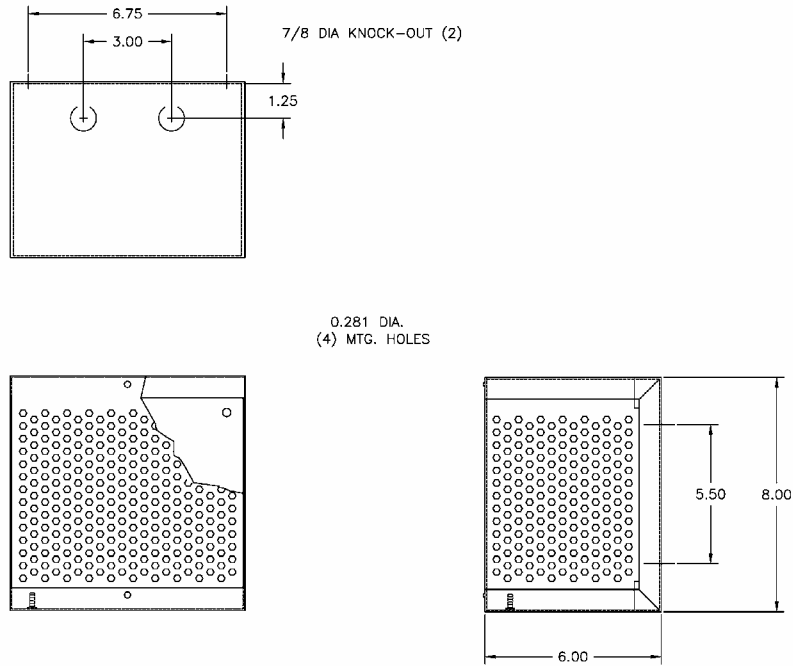

Figure 4 Cab – 8

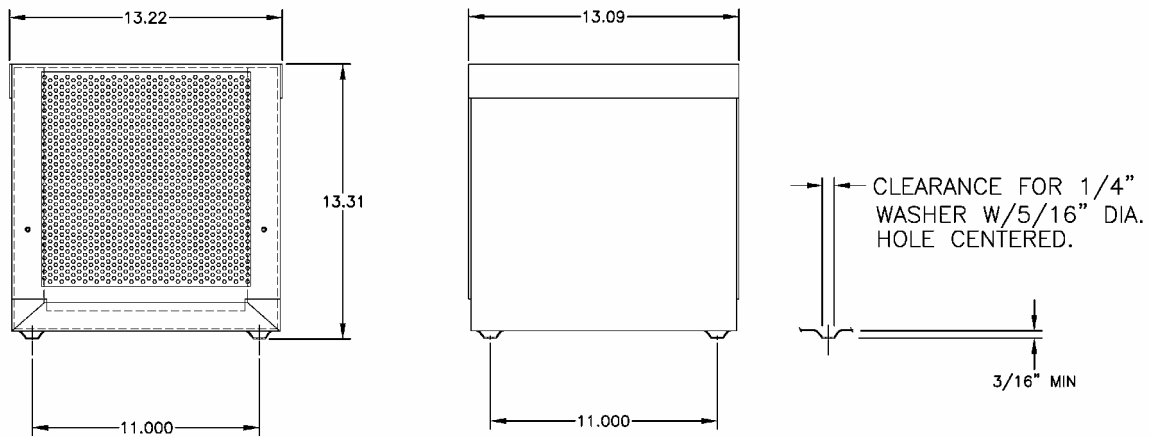

Figure 5 Cab 13V

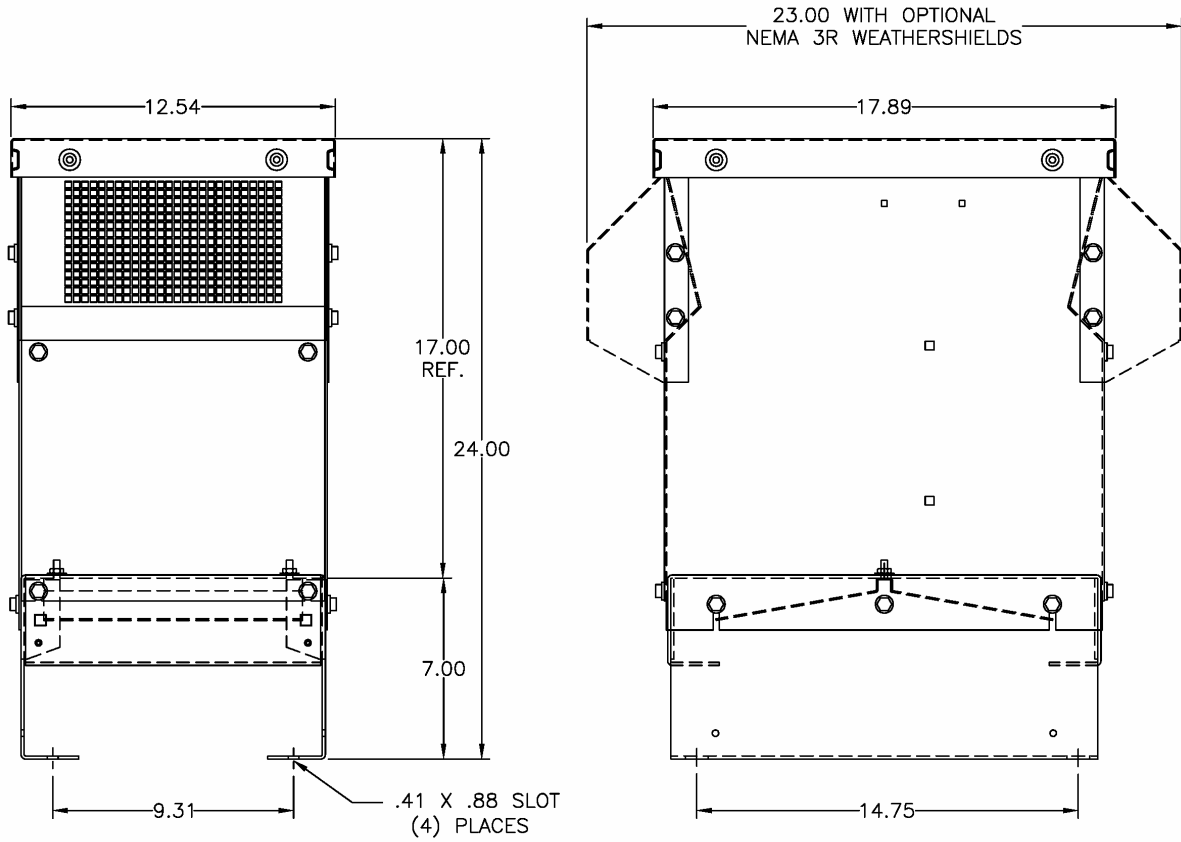

Figure 6 Cab 12C

Reactor Installation

MTE world reactors are available in open construction and in NEMA 1 enclosures. Open reactors are designed for mounting within an appropriate electrical equipment enclosure. Reactors rated 300 amperes RMS and under are designed for mounting in both a vertical and horizontal position. Larger reactors must be mounted in a horizontal position typically on the floor of the enclosure. Include the power dissipation of the reactor along with all the other components located in the enclosure to determine the internal temperature rise and cooling requirements of the enclosure.

Reactors may be located in any region of the enclosure where the ambient temperature does not exceed 45 degrees C. Allow a minimum side clearances of four (4) inches and vertical clearances of six (6) inches for proper heat dissipation and access. Do not locate the reactor next to resistors or any other component with operating surface temperatures above 125 degree C.

Select a well ventilated, dust-free area away from direct sunlight, rain or moisture. Do not install in or near a corrosive environment. Avoid locations where the reactor will be subjected to excessive vibrations.

NEMA 1 Enclosed world Reactor Installation

MTE line/load reactors mounted in enclosures with part number, CAB-8, are designed for wall mounting. All other enclosures are designed for floor mounting.

WARNING

MTE NEMA 1 enclosures designed for floor mounting must be mounted with the enclosure base horizontal for proper ventilation. Wall mounting a floor mounted enclosure with the base against the wall will cause the reactor to over heat resulting in equipment damage.

Allow a minimum side, front, and back clearances of twelve (12) inches and vertical clearances of eighteen (18) inches for proper heat dissipation and access. Do not locate the enclosure next to resistors or any other component with operating surface temperatures above 125 degree C.

Select a well ventilated, dust-free area away from direct sunlight, rain or moisture where the ambient temperature does not exceed 40 degrees C.

Do not install in or near a corrosive environment.

Avoid locations where the reactor will be subjected to excessive vibrations.

Where desirable, reactors or enclosures may be mounted on vibration isolating pads to reduce audible noise. Standard vibration control pads made from neoprene or natural rubber and selected for the weight of the enclosed reactor are effective.

Power Wiring Connection

WARNING

Input and output power wiring to the reactor should be performed by authorized personnel in accordance with the NEC and all local electrical codes and regulations.

Verify that the power source to which the reactor is to be connected is in agreement with the nameplate data on the reactor. A fused disconnect switch or circuit breaker should be installed between the reactor and its source of power in accordance with the requirements of the NEC and all local electrical codes and regulations. Refer to the drive, inverter, or other electrical equipment user manual for selection of the correct fuse rating and class.

The reactor is suitable for use on a circuit capable of delivering not more than 65,000 rms symmetrical amperes at 480 volts when protected by Bussman type JJS, KTK, KTK-R, SPP or T class fuses.

Reactors are designed for use with copper conductors with a minimum temperature rating of 75 degrees C. Table 2 lists the wire range and terminal torque requirements for the power input and output connections by reactor part number.

Refer to Figure 7 for typical electrical diagrams describing the application of reactors in both line and load applications. For reactors supplied as a component part of a drive system or a component part of power electronic apparatus follow the interconnection diagram supplied by the System Engineer.

Where desirable, a flexible conduit connection to the reactor enclosure should be made to reduce audible noise.

WARNING

Failure to connect reactors supplied as a component part of a drive system or other power electronic system according to the system interconnection diagram supplied by the System Engineer will result in equipment damage, injury, or death.

WARNING

If a line reactor or a line reactor and a load reactor are used with a drive equipped with a bypass circuit, the reactors must be removed from the motor circuit in the bypass mode. Damage to the motor and other equipment will result if this warning is not observed.

Grounding

A stud is provided on enclosed reactors for grounding the enclosure. The enclosure must be grounded. Open reactors must be grounded at the designated grounding terminal or the reactor mounting holes if no designated grounding terminal is provided.

WARNING

The frame of line/load reactors must be grounded at the designated grounding terminal or one of the reactor mounting holes if no designated grounding terminal is provided. The enclosure of reactors supplied in enclosures must be grounded.

INJURY OR DEATH MAY RESULT IF SAFETY PRECAUTIONS ARE NOT OBSERVED.

Connection Diagrams

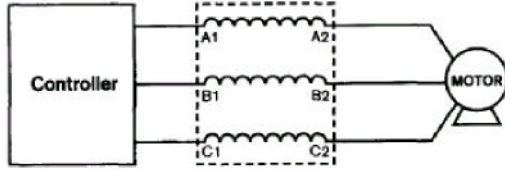

Load reactor connections
Note RLW requires 70% de-rating

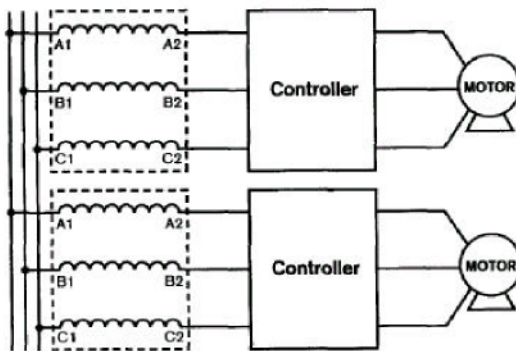

Conventional Line side reactor to VFD connections
Note; Actual lcc U1 -U2, V1-V2, W1-W2 designations on reactor terminals in place of A1-A2,B1-B2,C1-C2

Single phase connection

Standard three phase reactors may be used for single phase applications. Refer to *Application Note AN0102* for proper selection. Application Notes are available on our website at www.mtecorp.com.

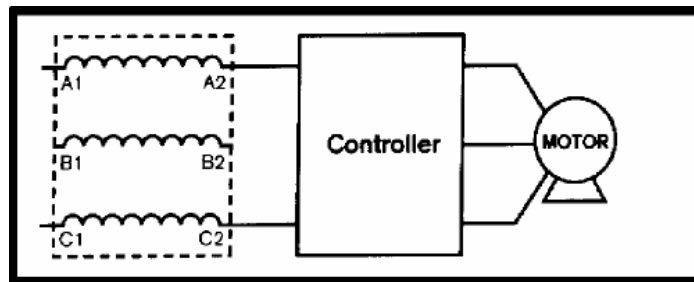

STARTUP

Safety Precautions

Before startup, observe the following warnings and instructions:

WARNING

A Reactor is at line potential when the Reactor is connected to the utility. This voltage is extremely dangerous and may cause death or severe injury if you come in contact with it.

WARNING

High voltage is used in the operation of line/load reactors. Use Extreme caution to avoid contact with high voltage when operating, installing or repairing equipment containing line/load reactors. Line/load reactors are used in conjunction with inverters, or other electrical equipment that may feedback lethal voltages.

Follow the safety instructions in the equipment used with the reactor in addition to the safety instruction in this manual.

INJURY OR DEATH MAY RESULT IF SAFETY PRECAUTIONS ARE NOT OBSERVED.

Sequence of Operation

1. Read and follow safety precautions.
2. After installation, ensure that:
 - All Reactor ground terminals are connected to ground.
 - Power wiring to the utility, drive and motor is in accordance with the interconnection diagrams supplied by the System Engineer.
3. Check that moisture has not condensed on the Reactor. If moisture is present, do not proceed with startup until the moisture has been removed.
4. Proceed with startup according to the instructions provided by the system supplier.

WARNING

Reactors are a component part of an electrical system. Do not proceed with startup until the system startup instructions provided by the System Engineer are understood and followed. Injury, death and damage to equipment may result if the system startup instructions are not followed.

WARNING

Use extreme caution to avoid contact with line voltage when checking for power

INJURY OR DEATH MAY RESULT IF SAFETY PRECAUTIONS ARE NOT OBSERVED.

ISO 7.2.3	AC Line / Load Reactors	PB-1101
Responsibility:	MTE Corporate	
Approved by:	Wayne Walcott	
File Location:	P:\Public\Controlled Documents\Sales\Price Book	
Revision	Date	Revision History
---	5/29/09	New document written by Wayne Walcott –