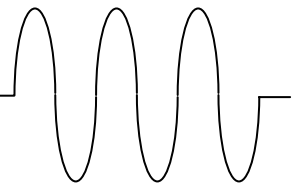


MTE Corporation

MATRIX FILTER TM

SERIES B
480 Volts, 60HZ

USER MANUAL



PART NO. INSTR - 014
REL. 071019

© 2007 MTE Corporation

IMPORTANT USER INFORMATION

NOTICE

The MTE Corporation Matrix Filter is designed for harmonic mitigation of six pulse inverter drives supplying variable torque loads in a wide variety of applications. The suitability of this filter for a specific application must therefore be determined by the customer. In no event will MTE Corporation assume responsibility or liability for any direct or consequential damages resulting from the use or application of this filter. Nor will MTE Corporation assume patent liability with respect to the use of information, circuits or equipment described in this instruction manual.

TABLE OF CONTENTS

TABLE OF CONTENTS	0
1. IMPORTANT SAFETY INFORMATION	1
2. INTRODUCTION	2
4. SPECIFICATIONS	4
RATINGS	4
SERVICE CONDITIONS	4
PERFORMANCE	5
WEIGHTS	6
ALTITUDE DERATING CURVE	10
5. INSTALLATION INSTRUCTIONS	11
FILTER INSTALLATION	11
OUTLINE DRAWINGS AND MOUNTING DIMENSIONS.....	12
Panel Mounted Filters	12
General purpose NEMA 1, 2 & 3R cabinets	23
POWER WIRING CONNECTION	30
INPUT AND OUTPUT TERMINAL SPECIFICATIONS.....	31
OVER TEMPERATURE SWITCH.....	32
INTERCONNECTION DIAGRAM	33
Terminal Locations NEMA 1-2	38
6. FILTER DESCRIPTION	47
480 VAC 60Hz BLOCK DIAGRAM	48
7. STARTUP	49
8. TROUBLESHOOTING	50

1. IMPORTANT SAFETY INFORMATION

WARNING

ONLY A QUALIFIED ELECTRICIAN CAN CARRY OUT THE ELECTRICAL INSTALLATION OF THIS FILTER

WARNING

High voltage is used in the operation of this filter. Use Extreme caution to avoid contact with high voltage when operating, installing or repairing this filter. **INJURY OR DEATH MAY RESULT IF SAFETY PRECAUTIONS ARE NOT OBSERVED.**

After removing power, allow at least five minutes to elapse and verify that the capacitors have discharged to a safe level before contacting internal components. Connect a DC voltmeter across the capacitor terminals or terminals 1, 2 and 3 on terminal block 1TB. Start with the meter on the highest scale and progressively switch to a lower scale as the indicated voltage falls below the maximum value of the scale used.

WARNING

The opening of the branch circuit protective device may be an indication that a fault current has been interrupted. To reduce the risk of fire or electrical shock, current-carrying parts and other components of the filter should be examined and replaced if damaged.

WARNING

An upstream disconnect/protection device must be used as required by the National Electrical Code (NEC).

WARNING

Even if the upstream disconnect/protection device is open, the drive down stream of the filter may feed back high voltage to the filter. The drive safety instructions must be followed. **INJURY OR DEATH MAY RESULT IF THE DRIVE SAFETY PRECAUTIONS ARE NOT OBSERVED.**

WARNING

The filter must be grounded with a grounding conductor connected to all grounding terminals.

WARNING

Only spare parts obtained from MTE Corporation or an authorized MTE distributor can be used.

2. INTRODUCTION

This manual was specifically developed to assist in the installation, interconnection and operation of the MTE Corporation Matrix Filter.

This manual is intended for use by personnel experienced in the operation and maintenance of electronic drives. Because of the high voltages required by the filter and drive and the potential dangers presented by rotating machinery, it is essential that all personnel involved in the operation and maintenance of this filter know and practice the necessary safety precautions for this type of equipment. Personnel should read and understand the instructions contained in this manual before installing, operating or servicing the filter and the drive to which the filter is connected.

Upon Receipt of this Filter:

The MTE Matrix Filter has been subjected to demanding factory tests before shipment. Carefully inspect the shipping container for damage that may have occurred in transit. Then unpack the filter and carefully inspect for any signs of damage. Save the shipping container for future transport of the filter.

In the event of damage, please contact and file a claim with the freight carrier involved immediately.

If the equipment is not going to be put into service upon receipt, cover and store the filter in a clean, dry location. After storage, ensure that the equipment is dry and that no condensation has accumulated on the internal components of the filter before applying power.

Repair/Exchange Procedure

MTE Corporation requires a Returned Material Authorization Number before it can accept any filters that qualify for return or repair. If problems or questions arise during installation, setup, or operation of the filter, please call us for assistance at:

Phone: 262-253-8200 ex 148

FAX: 262-253-8222

4. SPECIFICATIONS

Ratings

Table 1

480 VAC, 60 Hz SERIES B Filter Ratings				
THID Rating	8%		5%	
Maximum Output Amps RMS	Efficiency (Typical) (%)	Power Dissipation @ Rated Current (Typical) (Watts)	Efficiency (Typical) (%)	Power Dissipation @ Rated Current (Typical) (Watts)
6	97.2	139	97.4	132
8	97.5	164	97.6	161
11	97.8	200	97.8	197
14	98.0	233	98.0	232
21	98.3	299	98.3	294
27	98.4	351	98.5	343
34	98.6	406	98.6	399
44	98.7	479	98.7	472
52	98.8	539	98.8	533
66	98.9	626	98.9	621
83	98.9	740	98.9	735
103	99.0	850	99.0	844
128	99.1	964	99.1	959
165	99.2	1145	99.2	1143
208	99.2	1361	99.2	1355
240	99.3	1498	99.2	1493
320	99.3	1838	99.3	1829
403	99.4	2110	99.4	2098
482	99.4	2393	99.4	2371
636	99.4	2978	99.4	2929
786	99.5	3432	99.5	3402

Service Conditions

Load: 6 pulse variable torque rectifier only

Input voltage: 480 VAC +/- 10%, 60 ± 0.75 Hz, 3 phase

Input voltage line unbalance: 1% maximum

Maximum source impedance: 6.00%

Minimum source impedance: 1.5%

Service Factor: 1.00

SPECIFICATIONS - continued

Ambient Temperature (Operating)

Enclosed Filters:	-40 to +40 degrees C
Open Panel Filters:	-40 to +50 degrees C
Storage Temperature:	-40 to +90 degrees C

Altitude: 0 to 3300 Feet above sea level. Refer to Figure 6 for altitude derating.

Relative Humidity: 0 to 95% non-condensing

Agency Approvals

UL and cUL listed to UL508 and CSA-C22.2 No 14-95
File E180243 (3 – 1000 HP, 120VAC through 600 VAC
50, 50/60, 60 Hz Three Phase

Performance

Total Harmonic Current Distortion:

Eight Percent Filter: 8% typical at full load	12% maximum no load to full load
Five Percent Filter: 5% typical at full load	8% maximum no load to full load

Standby Current:

Without Optional Capacitor Contactor: 70% of the full load capacitor current listed in Table 3

With Optional Capacitor Contactor: Refer to Drive Users Manual

8% Filter Voltage Regulation with nominal 480 volts RMS source

Maximum output voltage at no load: 502 volts RMS, 710 volts peak

Maximum PCC* voltage with 6.00% source impedance at no load: 490 volts RMS, 693 volts peak

Minimum output voltage at full load: 460 volts RMS, 600 volts peak

5% Filter Voltage Regulation with nominal 480 volts RMS source

Maximum output voltage at no load: 502 volts RMS, 710 volts peak

Maximum PCC voltage with 6.00% source impedance at no load: 490 volts RMS, 693 volts peak

Minimum output voltage at full load: 460 volts RMS, 600 volts peak

*Note: PCC is the point of common coupling with the power distribution system

SPECIFICATIONS - continued

**Table 2
Weights**

480 Volt, 60 Hz Series B Matrix Filter Weights						
Output Amps RMS	Open Panel		General Purpose NEMA 1, 2, 3R		Industrial NEMA 1	
	THID		THID		THID	
	8% Weight Lbs	5% Weight Lbs	8% Weight Lbs	5% Weight Lbs	8% Weight Lbs	5% Weight Lbs
6	27	38	83	94	62	73
8	30	40	85	96	65	75
11	35	45	95	105	70	80
14	35	45	95	105	80	90
21	45	60	105	120	85	100
27	50	65	135	150	100	115
34	70	85	160	175	125	140
44	70	85	160	175	125	140
52	105	135	170	200	235	265
66	125	155	300	330	270	300
83	200	250	355	405	325	375
103	200	250	355	405	325	375
128	225	275	385	435	350	400
165	265	325	420	480	475	535
208	275	325	425	475	485	535
240	300	400	500	600	525	625
320	650	750	740	840	1175	---
403	700	825	830	955	1250	---
482	775	930	890	1045	1350	---
636	1375	1625	1200	1450	---	---
786	1575	1875	1400	1700	---	---

Table 3
480 VAC Matrix Filters
Capacitor Current at Full Load

Filter Current Rating Amps Rms	Capacitor Current (Typical) Amps RMS	Filter Current Rating Amps Rms	Capacitor Current (Typical) Amps RMS	Filter Current Rating Amps Rms	Capacitor Current (Typical) Amps RMS
6	2.0	44	14.5	208	79.7
8	2.7	52	20.7	240	93.1
11	3.9	66	21.5	320	124.8
14	5.4	83	31.5	403	156.0
21	7.1	103	33.6	482	188.9
27	10.7	128	39.3	636	246.4
34	13.1	165	56.4	786	303.4

Figure 1

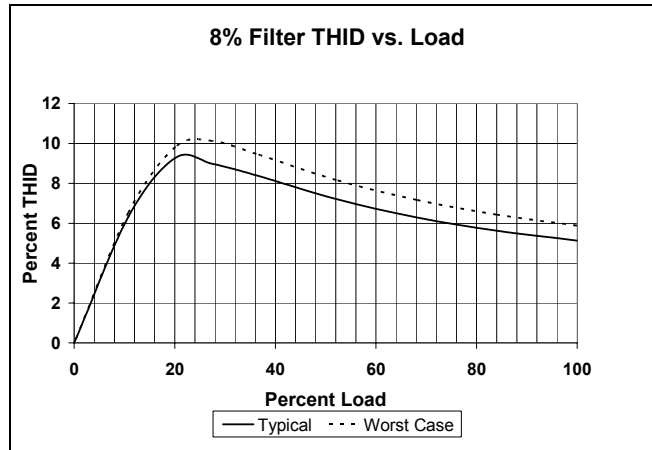


Figure 2

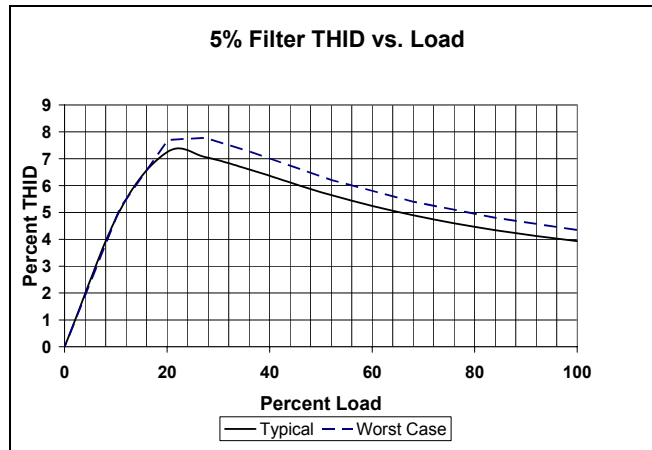


Figure 3

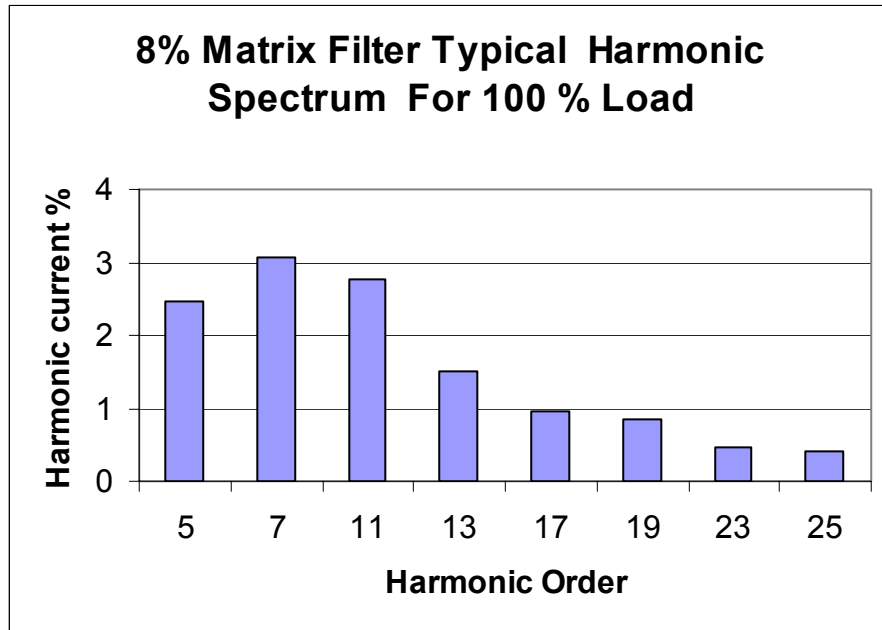


Figure 4

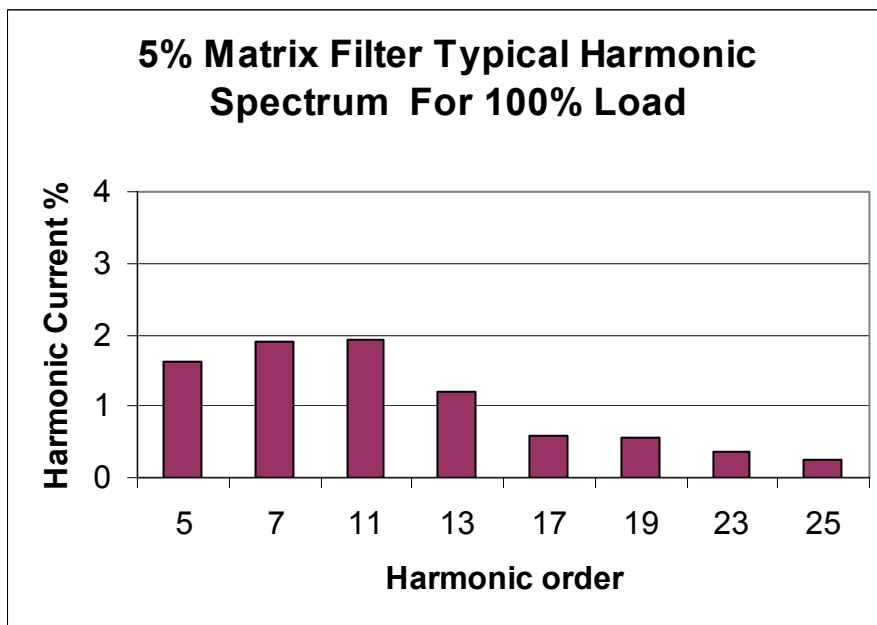
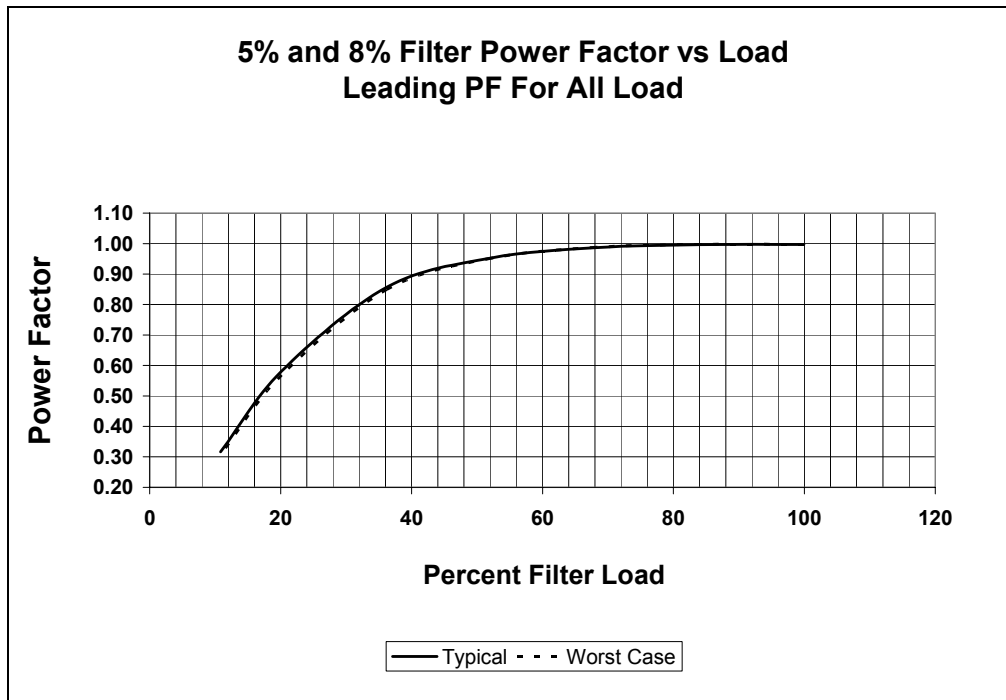


Figure 5

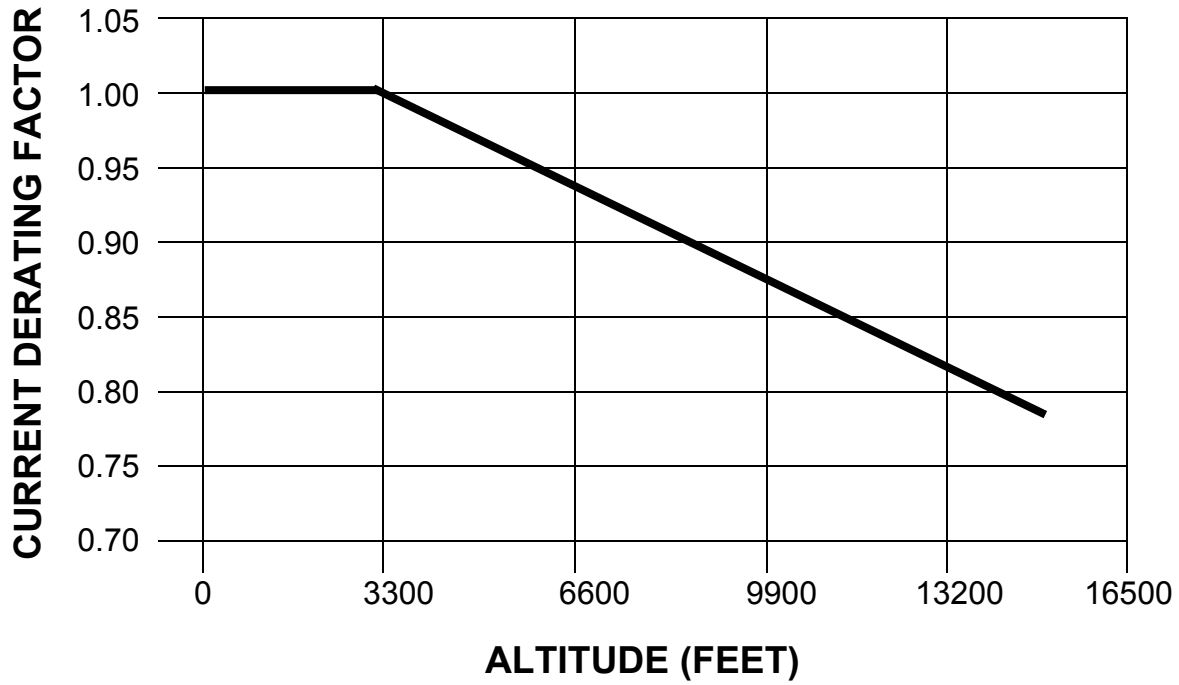


Performance With Unbalanced Line Voltage (Typical)

Table 4

All Components at Nominal Values and Worse Case Service Conditions		
	8% Filter 100% Load	5% Filter 100% Load
Nominal THID	5.12%	3.93%
1% Unbalance	5.28%	4.06%
2% Unbalance	5.82%	4.47%
3% Unbalance	6.62%	5.10%
	8% Filter 30% Load	5% Filter 30% Load
Nominal THID	10.13%	7.06%
1% Unbalance	10.61%	7.45%
2% Unbalance	12.11%	8.21%
3% Unbalance	14.30%	10.46%

Figure 6
Altitude Derating Curve



5. INSTALLATION INSTRUCTIONS

Filter Installation

Matrix Filters are supplied in the following mechanical configurations:

- Panel mounted assemblies

- Floor mounted general purpose NEMA 1, 2, & 3R cabinets

- Industrial style NEMA 1 cabinets with hinged doors.

Panel mounted filters are designed for mounting in the vertical plane in the customer's enclosure. Include the power dissipation of the filter along with all the other components located in the panel to determine the internal temperature rise and cooling requirements of the enclosure. Allow a minimum side clearance of four (4) inches and a vertical clearance of six (6) inches for proper heat dissipation and access. Figure 7 through Figure 16 contain outline drawings for the various ratings and show proper mounting orientation. For 5% filters, Model numbers beginning with M5, refer to Figure 17 and Table 5 for the dimensions of the separately mounted input reactor.

Select a well ventilated, dust-free area away from direct sunlight, rain or moisture. Do not install in or near a corrosive environment. Avoid locations where the filter would be subjected to excessive vibrations.

General purpose NEMA 1, 2, and 3R enclosed filters are designed for floor mounting in the vertical plane in an environment suitable for the enclosure type. Do not install in or near a corrosive environment. Avoid locations where the filter would be subjected to excessive vibrations. Allow a minimum side and back clearance of eight (8) inches and front clearance of thirty-six (36) inches for proper heat dissipation and access. Table 6 will direct you to the appropriate outline drawings shown in Figure 18 through Figure 21.

Industrial style NEMA 1 enclosed filters are designed for wall and floor mounting in the

vertical plane. Do not install in or near a corrosive environment. Avoid locations where the filter would be subjected to excessive vibrations. For wall mounted enclosures allow a minimum side clearance of eight (8) inches and front clearance of forty-eight (48) inches for proper heat dissipation and access. For floor mounted enclosures allow a minimum side and back clearance of eight (8) inches and front clearance of forty-eight (48) inches for proper heat dissipation and access. Table 7 will direct you to the appropriate outline drawings shown in figures 22-26

INSTALLATION INSTRUCTIONS - continued

Outline Drawings and mounting Dimensions

Panel Mounted Filters

Figure 7

6 – 21 Amps, 480 VAC 60Hz Outline Drawing

All dimensions are in inches

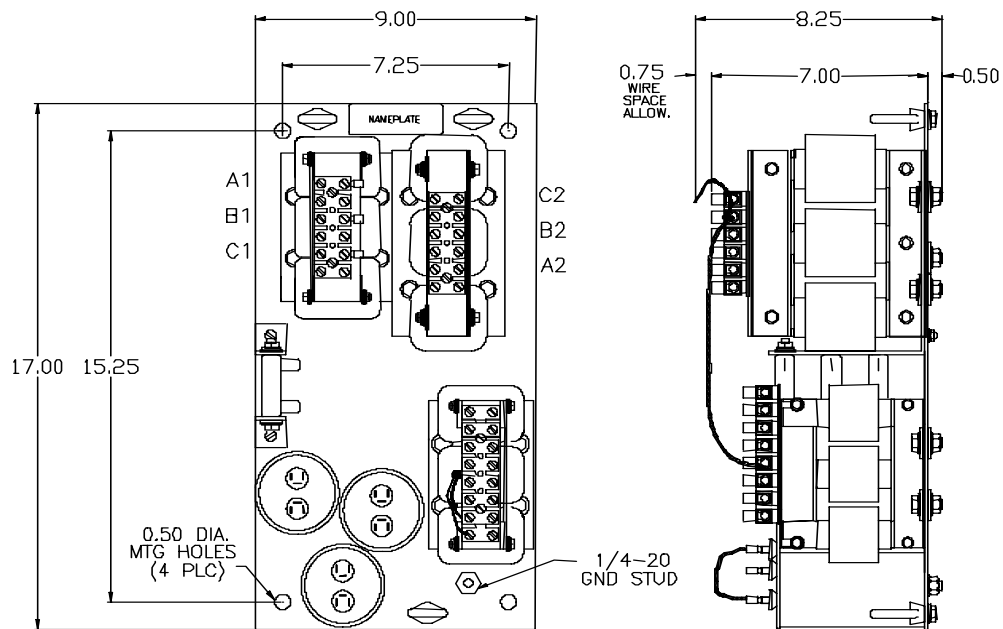


Figure 8
27 Amps, 480 VAC 60Hz Outline Drawing

All dimensions are in inches

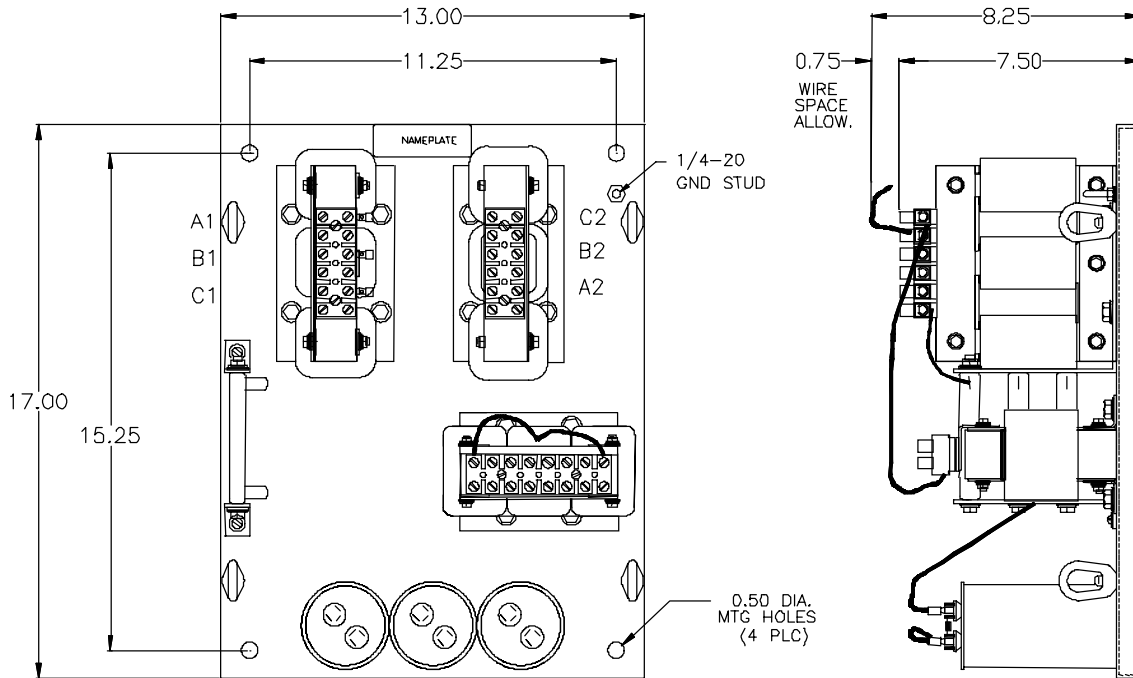
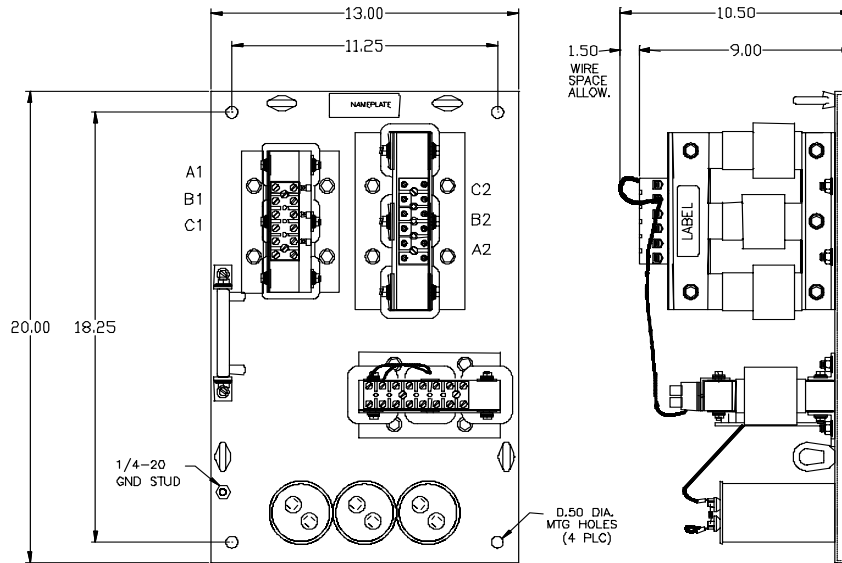


Figure 9

34 – 44 Amps, 480 VAC 60Hz Outline Drawing

All dimensions are in inches



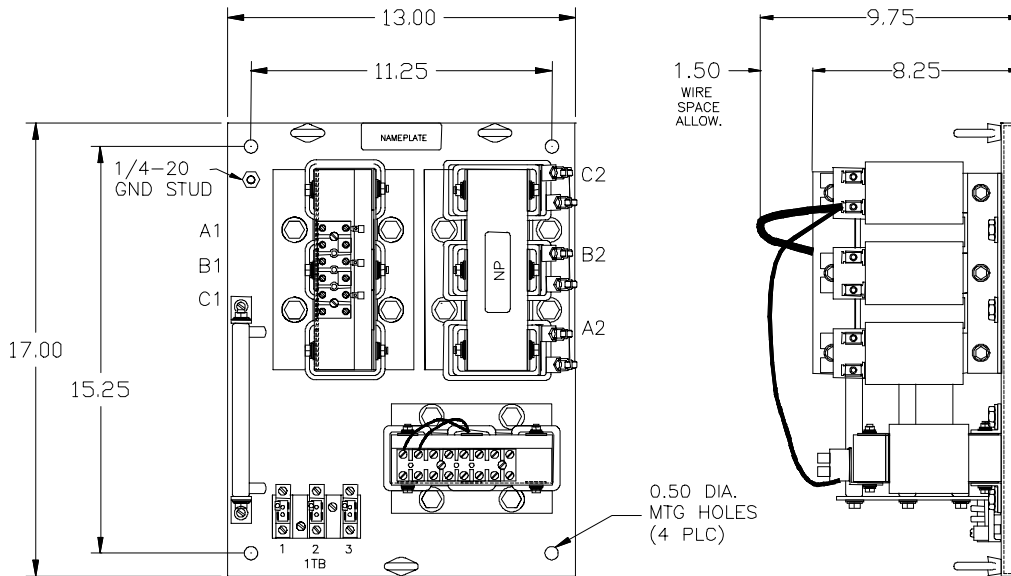
INSTALLATION INSTRUCTIONS - continued

Figure 10

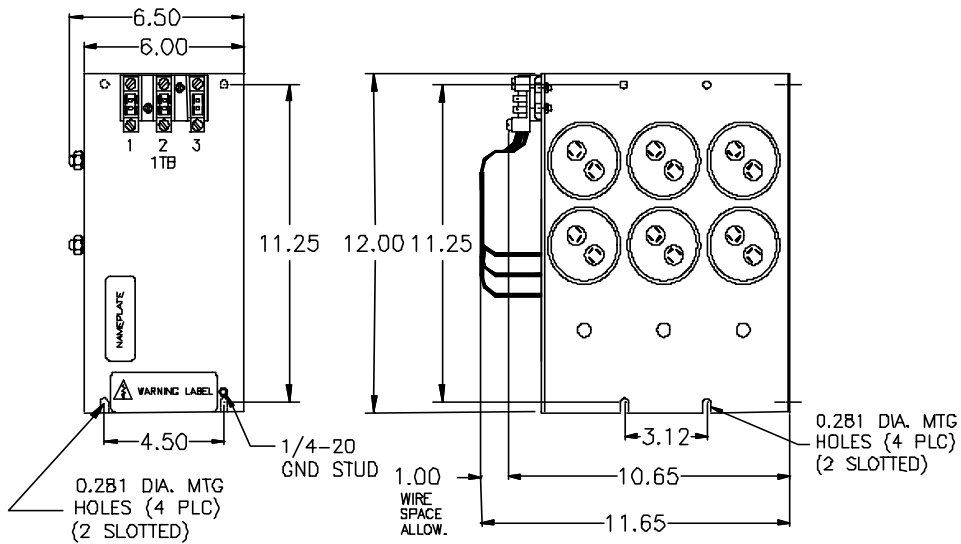
52 - 66 Amps, 480 VAC 60Hz Outline Drawing

All dimensions are in inches

REACTOR ASSEMBLY



CAPACITOR ASSEMBLY



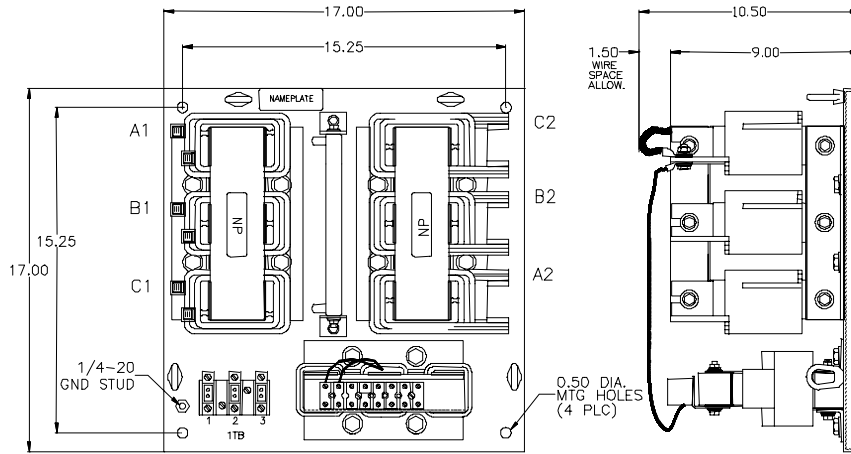
NOTE: CAPACITOR ASSEMBLY MAY BE MOUNTED IN EITHER PLANE

INSTALLATION INSTRUCTIONS - continued

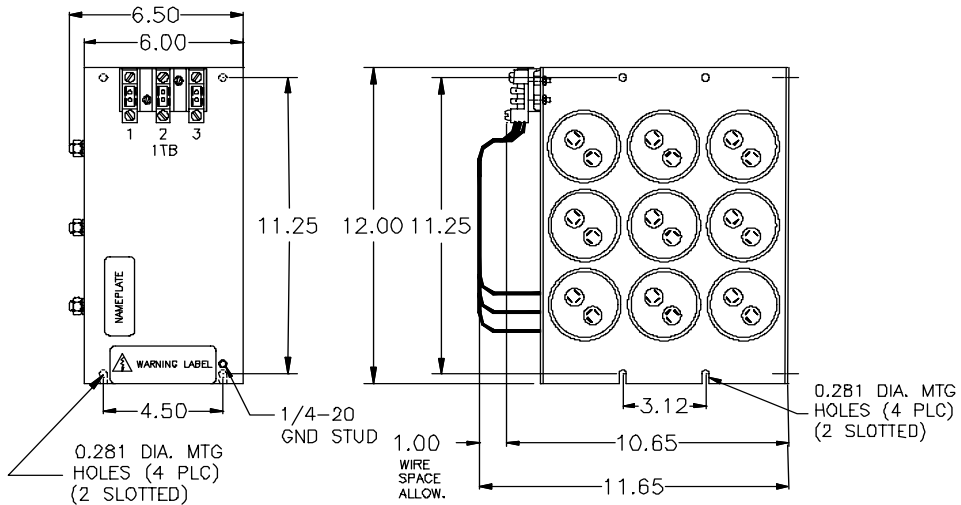
Figure 11
83 – 128 Amps, 480 VAC 60Hz Outline Drawing

All dimensions are in inches

REACTOR ASSEMBLY



CAPACITOR ASSEMBLY



NOTE: CAPACITOR ASSEMBLY MAY BE MOUNTED IN EITHER PLANE

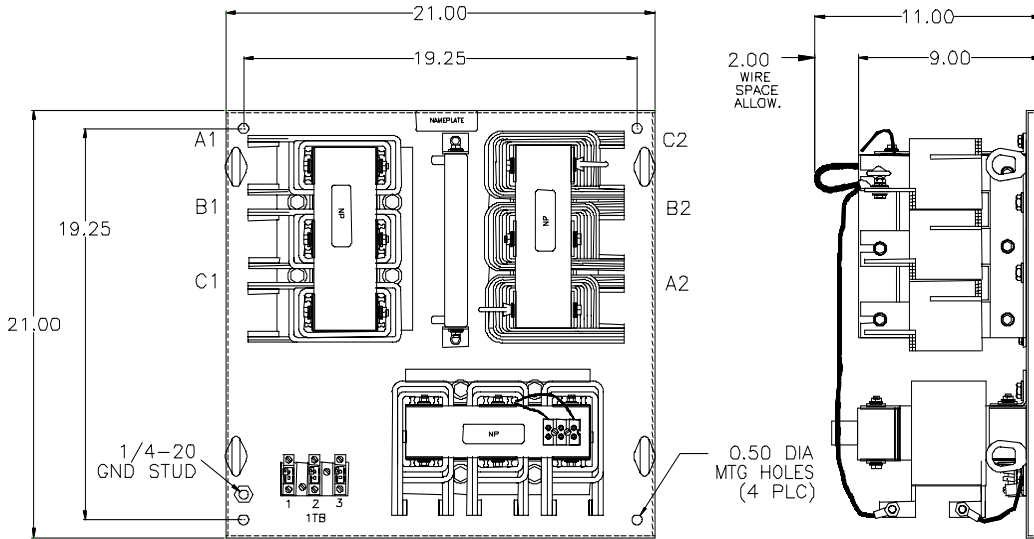
INSTALLATION INSTRUCTIONS - continued

Figure 12

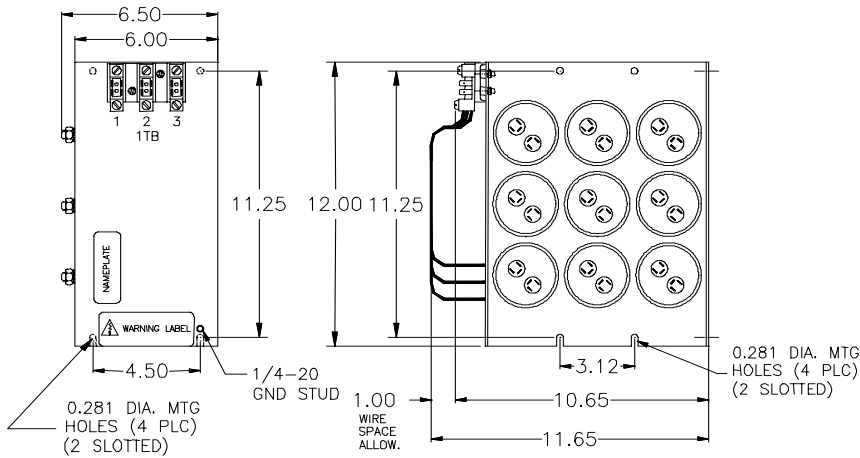
165 – 240 Amps, 480 VAC 60Hz Outline Drawing

All dimensions are in inches

REACTOR ASSEMBLY



NOTE: SEE TABLE FOR NUMBER OF CAPACITOR ASSEMBLIES



AMPS	NO. OF CAPACITOR PANELS
165	1
208	2
240	2

NOTE: CAPACITOR ASSEMBLY MAY BE MOUNTED IN EITHER PLANE

Figure 13

320 – 482 Amps, 480 VAC 60Hz Vertical Mounting Outline Drawing

All dimensions are in inches

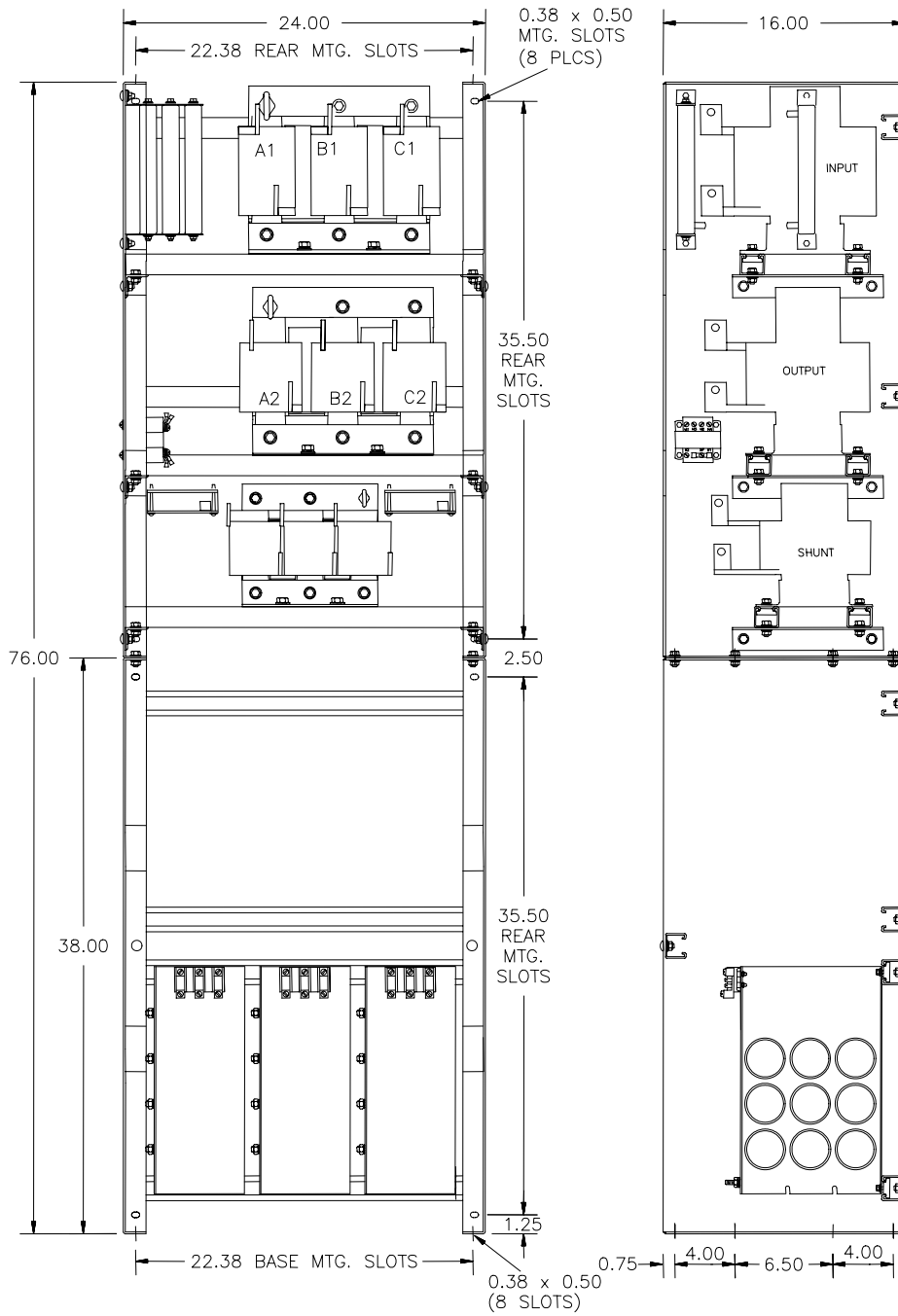
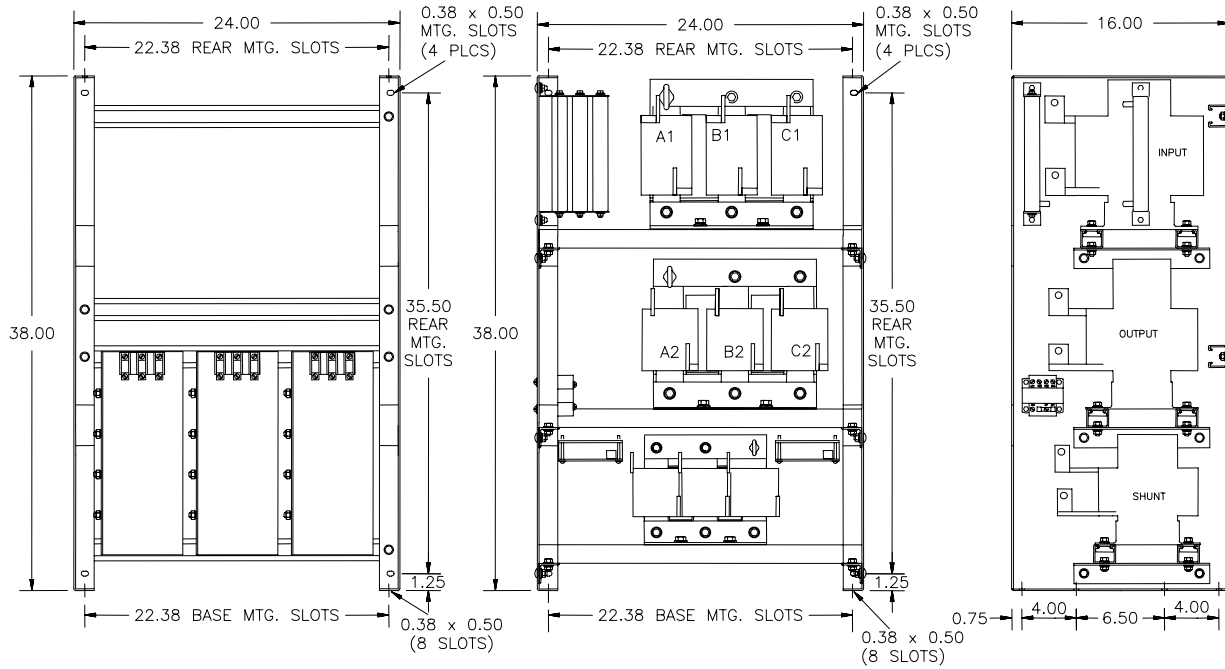


Figure 14

320 – 482 Amps, 480 VAC 60Hz Horizontal Mounting Outline Drawing

All dimensions are in inches



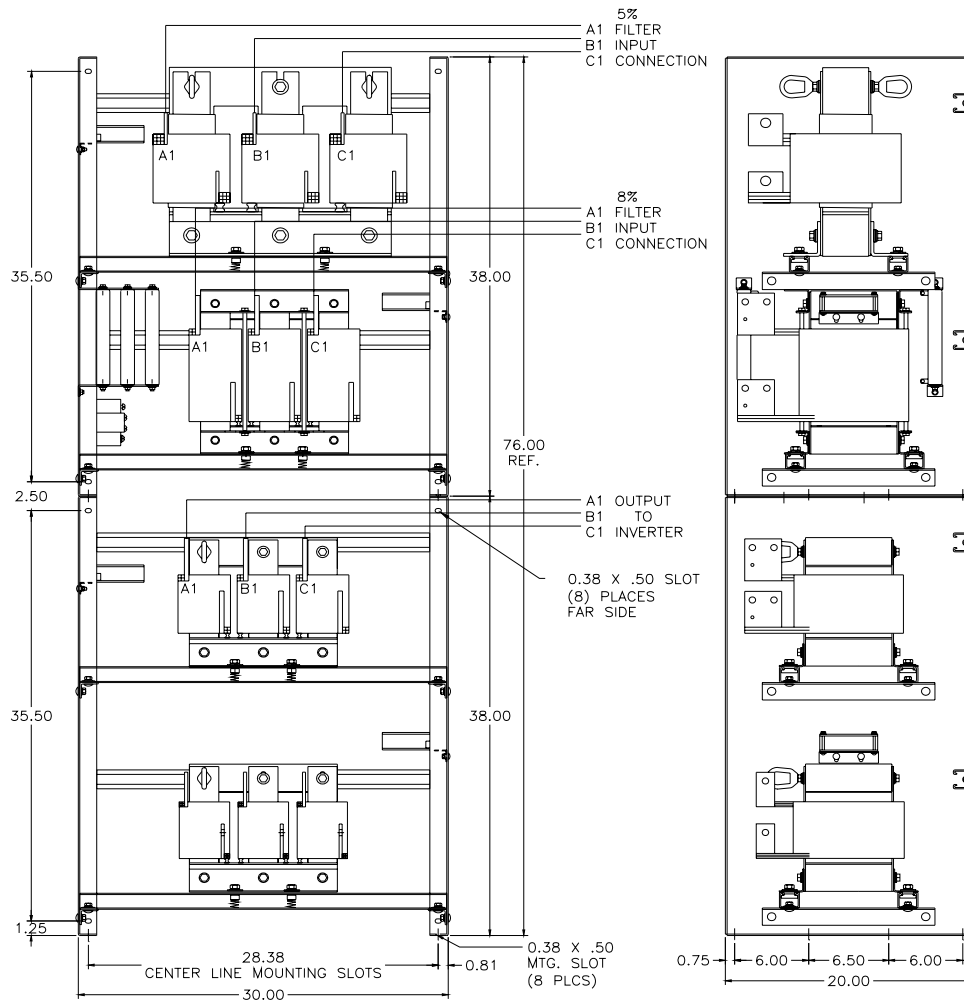
480 VAC Matrix Filters rated 320 amps through 786 amps are constructed from a reactor assembly and a capacitor assembly. These assemblies are designed to be mounted vertically. The reactor assembly may be mounted above the capacitor assembly as shown in Figure 13 or the assemblies may be mounted separately as shown in Figure 14. The capacitor assembly should be located in the lowest temperature regions of the enclosure – generally toward the bottom. For 480 VAC Matrix Filters rated 636 amps through 786 amps see Figures 16 and 17.

The reactor and capacitor assemblies are shipped vertically oriented bolted and banded front-to-back to a common pallet.

Figure 15

636 – 786 Amps, 480 VAC 60Hz Vertical Mounting Outline Drawing

All dimensions are in inches

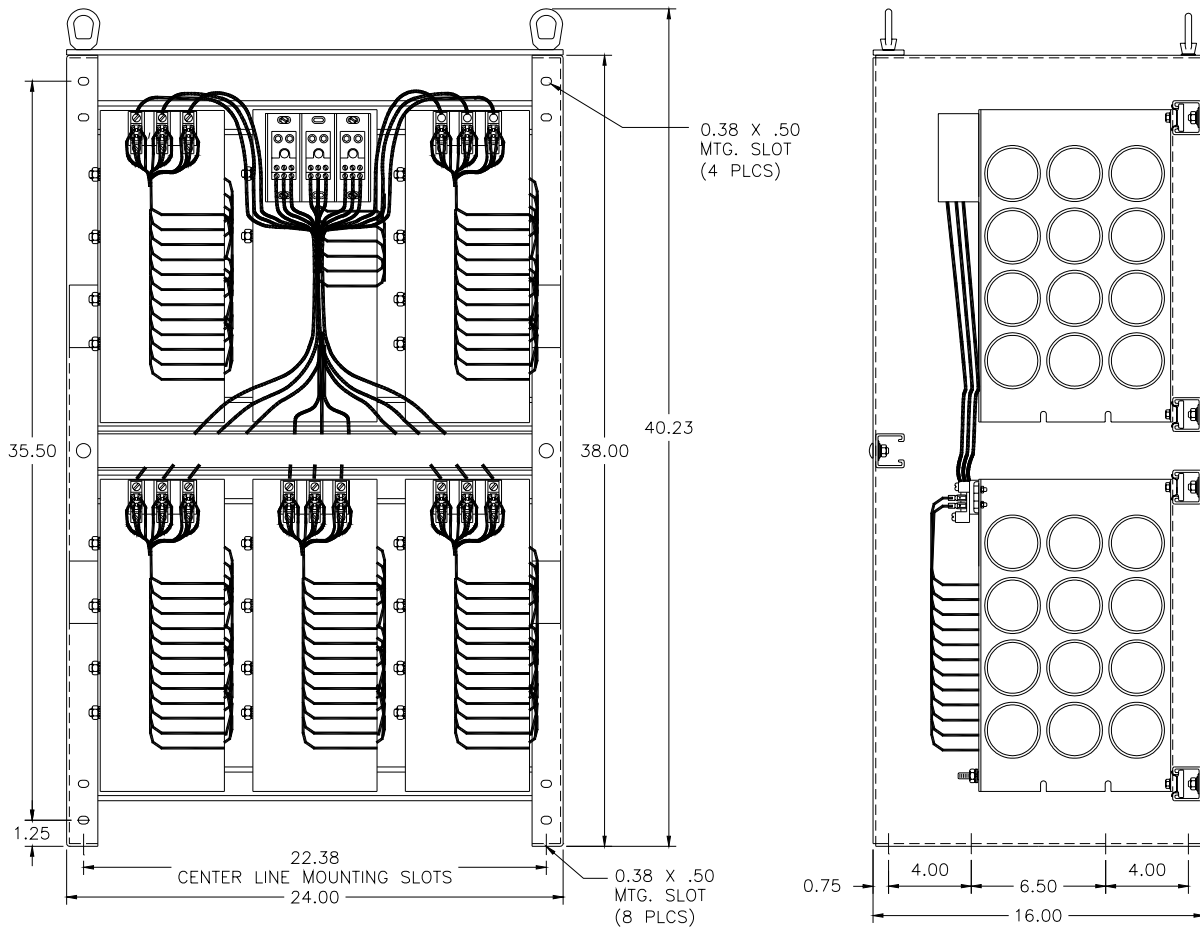


INSTALLATION INSTRUCTIONS - continued

Figure 16

636 – 786 Amps, 480 VAC 60Hz Capacitor Assembly Outline Drawing

All dimensions are in inches



INSTALLATION INSTRUCTIONS - continued

Figure 17

5% PANEL MOUNTED FILTER INPUT REACTOR MOUNTING DIMENSIONS

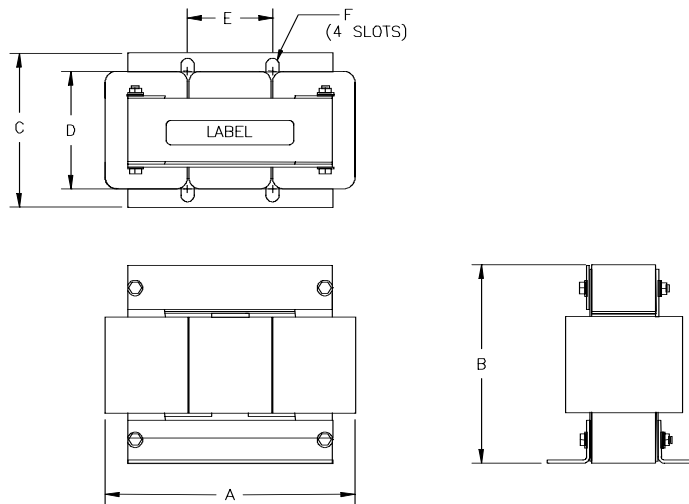


TABLE 5

FILTER RATING AMPS	A Inches	B Inches	C Inches	D Inches	E Inches	F Inches	WEIGHT LBS
6	6.0	5.0	3.4	2.62	2.0	0.281	11
8	6.0	5.0	3.4	2.62	2.0	0.281	11
11	6.0	4.8	3.0	2.10	2.0	0.281	8
14	6.0	5.0	3.3	2.10	2.0	0.281	10
21	6.0	5.3	3.5	2.48	2.0	0.281	12
27	7.3	6.0	3.5	2.35	3.0	0.390	14
34	7.3	5.8	4.0	2.75	3.0	0.390	16
44	7.3	5.8	4.0	2.75	3.0	0.390	16
52	9.0	7.4	4.8	3.16	3.0	0.38 x 0.75	28
66	9.0	7.0	5.3	3.16	3.0	0.38 x 0.75	27
83	10.8	8.5	6.5	3.47	3.63	0.38 x 0.75	51
103	10.8	8.5	6.5	3.47	3.63	0.38 x 0.75	51
128	11.0	8.5	6.7	3.66	3.63	0.38 x 0.75	51
165	10.8	8.5	6.8	3.66	3.63	0.38 x 0.75	62
208	11.0	8.5	7.0	3.47	3.63	0.38 x 0.75	51
240	10.8	8.5	10.0	5.91	3.63	0.38 x 0.75	100
320	15.0	11.4	10.3	5.16	4.60	0.56 x 1.0	106
403	14.8	11.3	11.0	5.88	4.60	0.56 x 1.0	125
482	15.5	11.3	12.1	6.76	4.60	0.56 x 1.0	155
636	15.5	11.5	12.5	6.76	4.60	0.56 x 1.0	180
786	15.5	11.3	12.5	8.0	4.60	0.56 x 1.0	250

INSTALLATION INSTRUCTIONS - continued

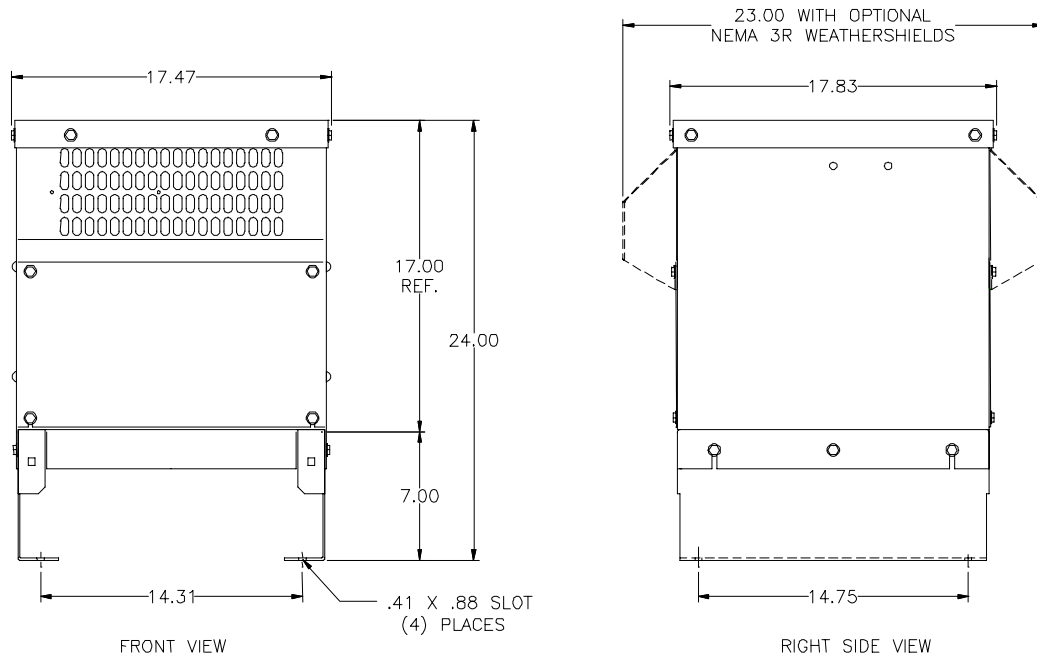
General purpose NEMA 1, 2 & 3R cabinets

Table 6

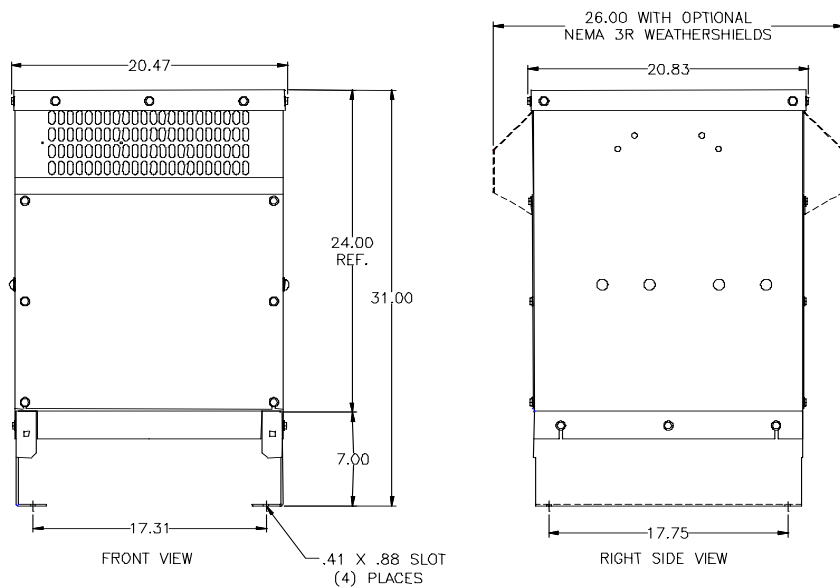
General Purpose Cabinets NEMA 1, 2, & 3R	
Filter Output Rating Amps.	Cabinet Part Number
6	CAB-17B
8	CAB-17B
11	CAB-17B
14	CAB-17B
21	CAB-20B
27	CAB-20B
34	CAB-20B
44	CAB-20B
52	CAB-20B
66	CAB-30B
83	CAB-30B
103	CAB-30B
128	CAB-30B
165	CAB-30B
208	CAB-30B
240	CAB-30B
320	CAB-42B
403	CAB-42B
482	CAB-42B
636	CAB-42B
786	CAB-42B

INSTALLATION INSTRUCTIONS - continued

**Figure 18
CAB-17B**

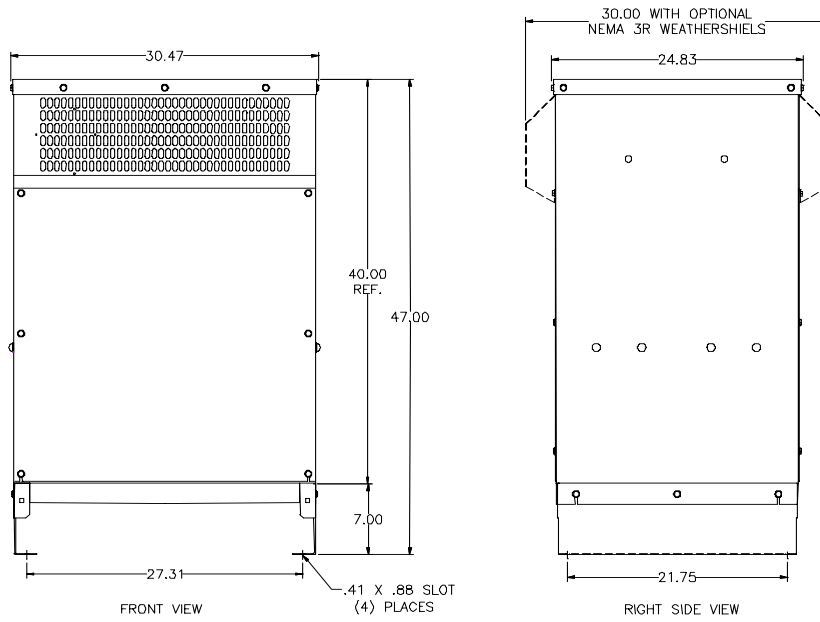


**Figure 19
CAB-20B**

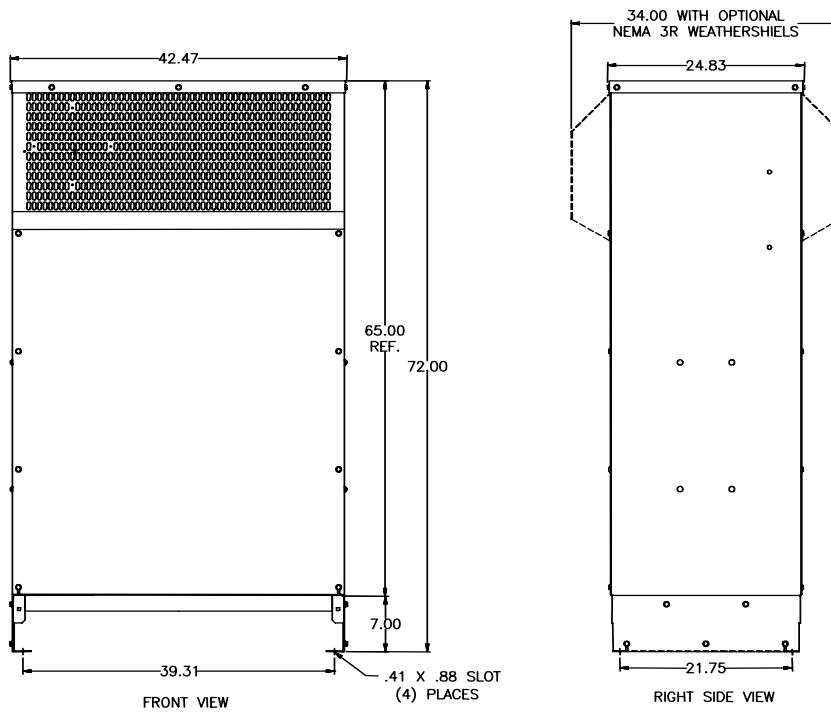


INSTALLATION INSTRUCTIONS - continued

**Figure 20
CAB-30B**



**Figure 21
CAB-42B**



Mounting dimensions and outline drawings for wall and floor mounted NEMA 1 cabinets follow.

INSTALLATION INSTRUCTIONS - continued

Table 7

NEMA 1 Industrial Style Enclosures	
Filter Output Rating Amps.	Cabinet Part Number
6	Cabinet-002
8	Cabinet-002
11	Cabinet-002
14	Cabinet-002
21	Cabinet-002
27	Cabinet-003
34	Cabinet-003
44	Cabinet-003
52	Cabinet-004
66	Cabinet-004
83	Cabinet-004
103	Cabinet-004
128	Cabinet-004
165	Cabinet-005
208	Cabinet-005
240	Cabinet-005
320	Cabinet-006*
403	Cabinet-006*
482	Cabinet-006*
636	N/A
786	N/A

*Floor Mounted

INSTALLATION INSTRUCTIONS - continued

Figure 22 Cabinet-002

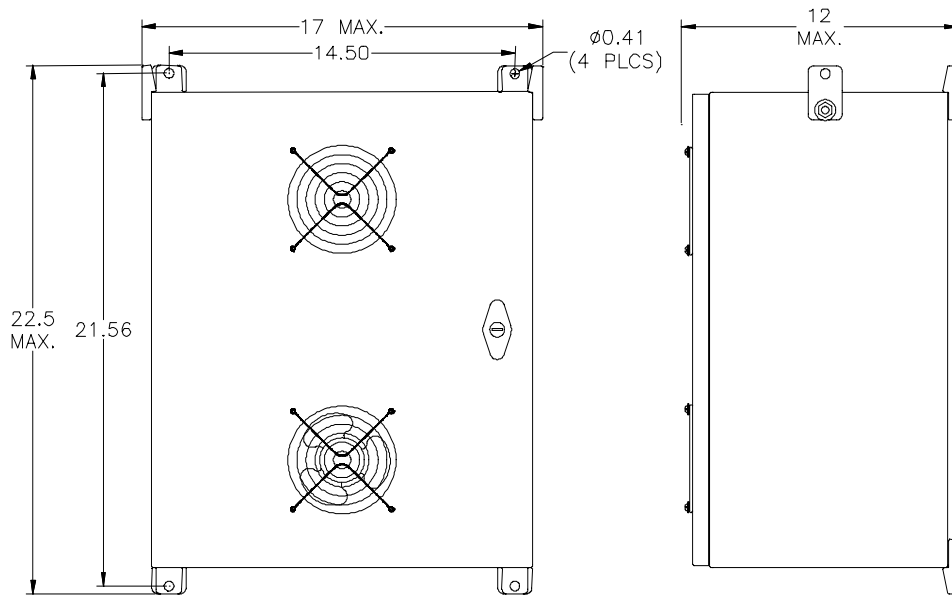
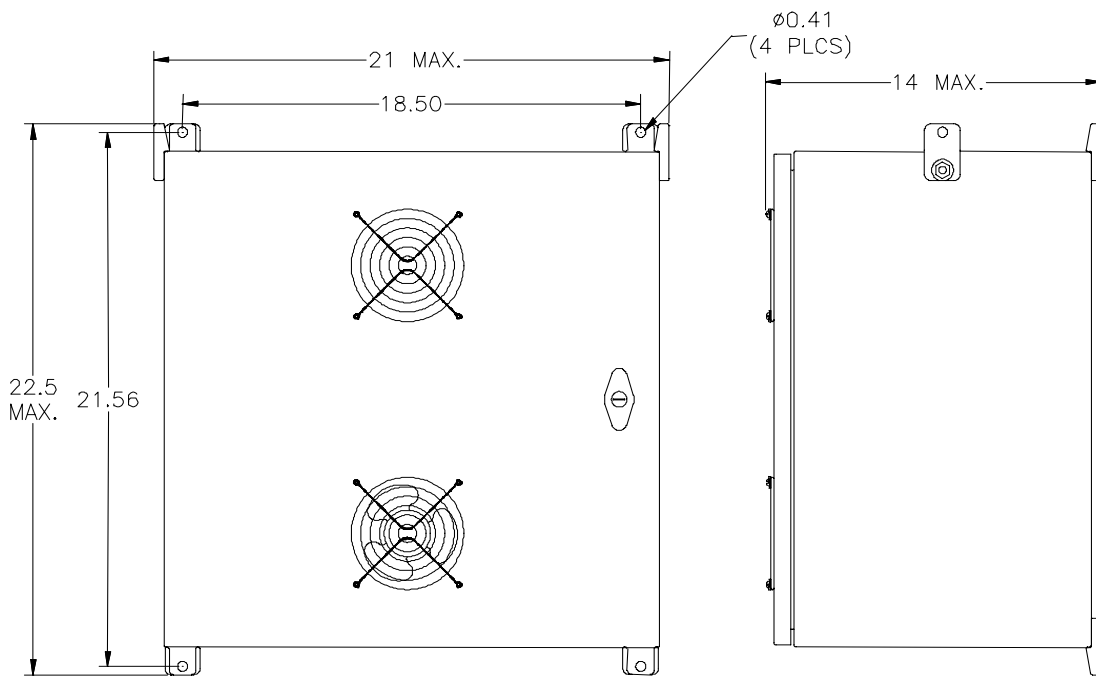
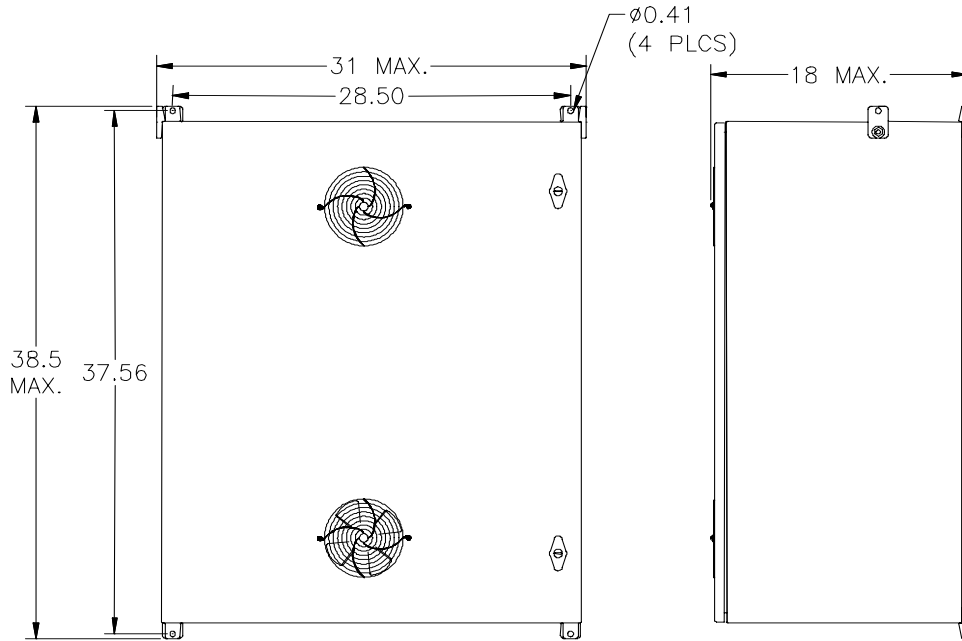


Figure 23 Cabinet-003

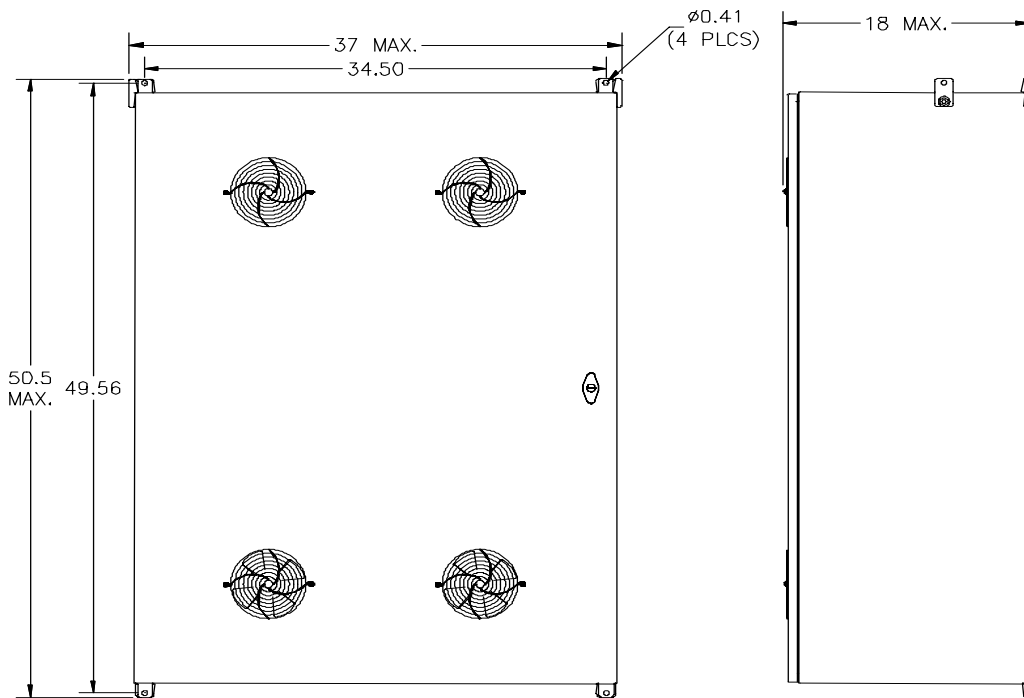


INSTALLATION INSTRUCTIONS - continued

**Figure 24
Cabinet-004**

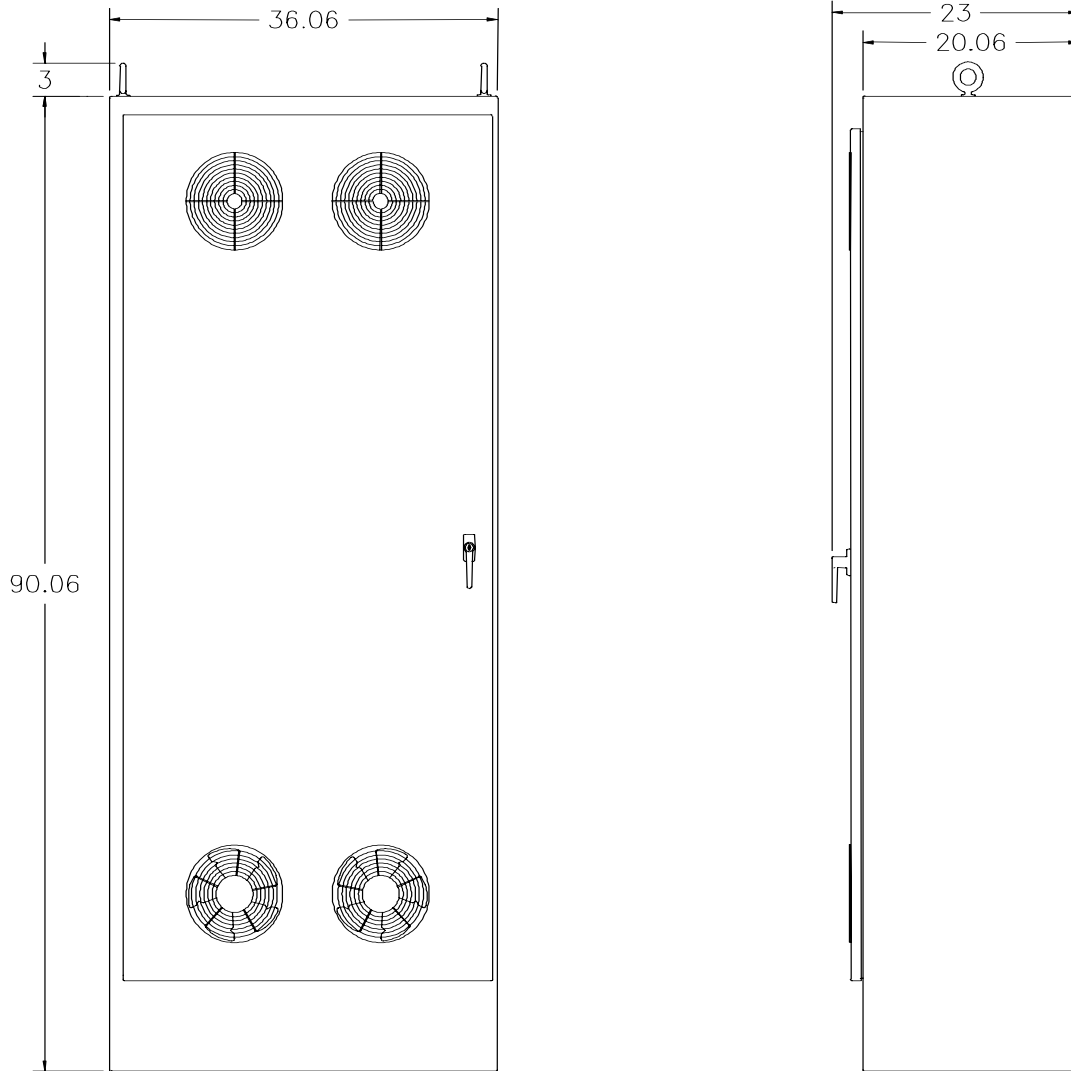


**Figure 25
Cabinet-005**



INSTALLATION INSTRUCTIONS - continued

Figure 26
Cabinet-006



Note: For 5% filters rated 320 Amps to 482 Amps a separately mounted input reactor is required. Refer to Figure 17 for mounting dimensions.

Power Wiring Connection

WARNING

Input and output power wiring to the filter should be performed by authorized personnel in accordance with the NEC and all local electrical codes and regulations.

Verify that the power source to which the filter is to be connected is in agreement with the nameplate data on the filter. A fused disconnect switch or circuit breaker should be installed between the filter and its source of power in accordance with the requirements of the NEC and all local electrical codes and regulations. Refer to the drive user manual for selection of the correct fuse rating and class.

The filter is suitable for use on a circuit capable of delivering not more than 100,000 rms symmetrical amperes at 480 volts maximum when protected by type J, T or RK1 class fuses or a circuit breaker.

For panel mounted filter applications rated 44 amperes and below, interconnection between the filter, its power source, and the drive is shown in Figure 27. Refer to the drive user manual for instructions on interconnecting the drive and motor and the correct start-up procedures for the drive.

The filter is designed for use with copper conductors with a minimum temperature rating of 75 degrees C.

Table 8 lists the wire range and terminal torque requirements for the power input and output connections by horsepower rating.

For panel mounted filters rated 52 amperes or more, the filter reactors are supplied on a sub-panel and the filter capacitors are supplied on one or more assemblies. Refer

to Figure 28 for the interconnection diagram. The capacitor assembly should be located in the lowest temperature regions of the enclosure – generally toward the bottom – and the reactor assembly may be located in any region where the ambient temperature does not exceed 50 degrees C. Size the conductors interconnecting the reactor and capacitor assemblies to carry the current shown in Table 3. For terminal specifications on the capacitor assembly, refer to Table 10.

For filters supplied in general purpose NEMA 1, 2 & 3R cabinets, interconnection between the filter, its power source, and the drive is shown in Figure 29. Refer to Figures 31 to 34 for the location of input, output, ground and over temperature switch terminals. Refer to the drive user manual for instructions on interconnecting the drive and motor and the correct start-up procedures for the drive.

For filters supplied in industrial style NEMA 1 cabinets, interconnection between the filter, its power source and the drive is shown in Figure 30. Refer to Figures 35 to 39 for the location of input, output, ground and over temperature switch terminals. Refer to the drive user manual for instructions on interconnecting the drive and motor and the correct start-up procedures for the drive.

Grounding and Ground Fault Protection

The filter must always be grounded with a grounding conductor connected to all ground terminals.

Due to high leakage currents associated with variable frequency drives, ground fault protective devices do not necessarily operate correctly when placed ahead of a matrix filter feeding a drive. When using this type of device, its function should be tested in the actual installation.

INSTALLATION INSTRUCTIONS - continued

Table 8
Input and Output Terminal Specifications

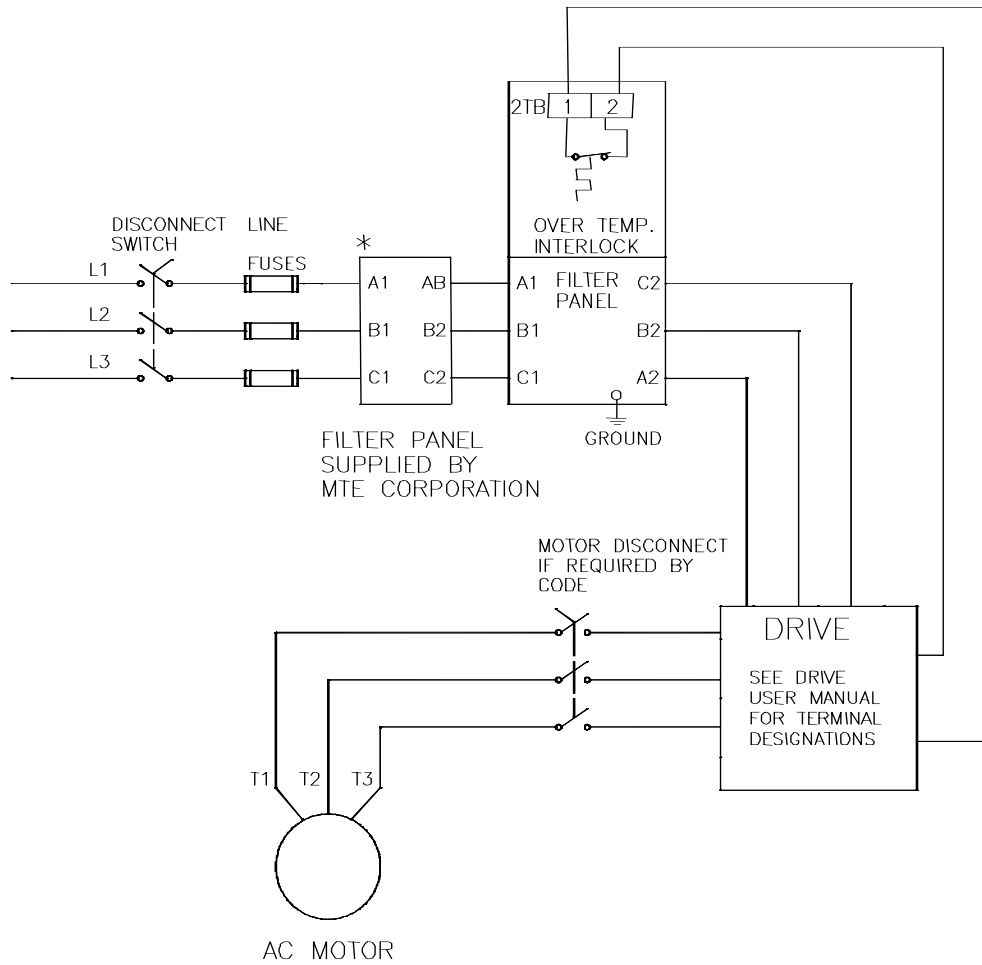
Filter Rating(Amps)	Input Terminals		Output Terminals	
	Wire Range (AWG)	Terminal Torque (in-lbs)	Wire Range (AWG)	Terminal Torque (in-lbs)
6	22 -14	4.5	22 – 14	4.5
8				
11	22 - 14	4.5	22 – 14	4.5
14	22 - 14	4.5	22 – 5	16
21	22 - 5	16	22 – 5	16
27	22 - 5	16	22 – 5	16
34	22 - 5	16	18 – 4	20
44	22 - 5	16	18 – 4	20
52	18 – 4	20	18 – 4	20
66	18 – 4	20	6-4 2-0	45 50
83	6-4 2-0	45 50	6-4 2-0	45 50
103	6-4 2-0	45 50	6-4 2-0	45 50
128	6-4 2-0	45 50	6-4 2-0	45 50
165	6-4 2-0	45 50	2-0000	150
208	2 – 0000	150	2 – 0000	150
240	2 – 0000	150	2 – 0000	150
320	2-0000	150	00 000-0000 250-350 MCM 500 MCM	180 250 325 375
403	00 000-0000 250-350 MCM 500 MCM	180 250 325 375	00 000-0000 250-350 MCM 500 MCM	180 250 325 375
482	00 000-0000 250-350 MCM 500 MCM	180 250 325 375	00 000-0000 250-350 MCM 500 MCM	180 250 325 375
636	NA	NA	NA	NA
786	NA	NA	NA	NA

Over Temperature Switch

Table 9

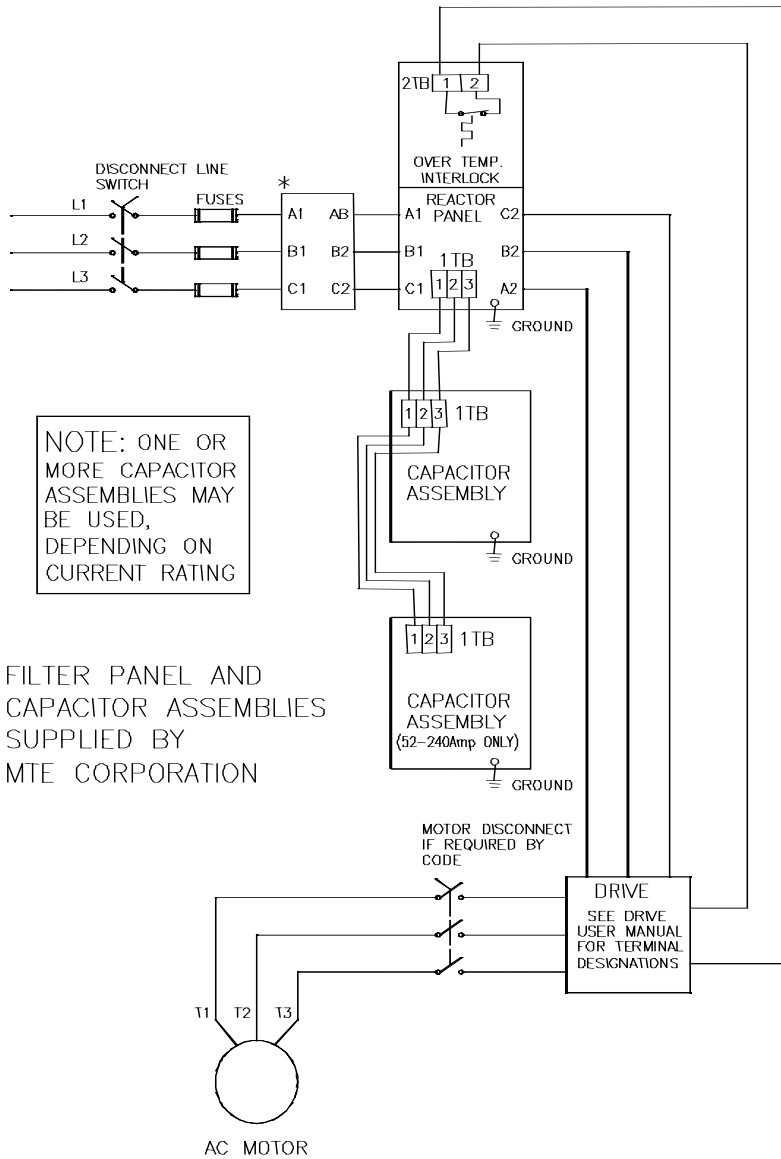
TYPE	BI – METAL THERMAL SWITCH
CONTACT	(NC) NORMALLY CLOSED Slow break / slow make
RATINGS	<p>6A 120 VAC RESISTIVE 3A 240 VAC RESISTIVE 8A 12 VDC RESISTIVE 4A 24 VDC RESISTIVE</p> <p>5A 120 VAC INDUCTIVE 2.5A 240 VAC INDUCTIVE</p>
TEMPERATURE CONTACTS	Open at 180°C +/- 5

Figure 27
Panel Mounted Filters 6 – 44 Amps, 480 VAC 60Hz
Interconnection Diagram



* INPUT REACTOR REQUIRED FOR 5% FILTERS

Figure 28
Panel Mounted Filters 52 – 786 Amps 480 VAC 60Hz
Interconnection Diagram



* INPUT REACTOR REQUIRED FOR 5% FILTERS

INSTALLATION INSTRUCTIONS - continued

Table 10
Capacitor Assembly Terminal Specifications

Filter Rating (Amps)	Capacitor Terminals <i>NOTE: Two terminals per phase</i>	
	Wire Range (AWG)	Terminal Torque (in lbs)
52 – 240	14 – 10 8 4 – 6 1/0 – 3	35 40 45 50
320 - 482	6-00	120

Figure 29

**Filters Mounted in General Purpose NEMA 1, 2 & 3R Cabinets
6 – 786 Amps, 480 VAC 60Hz Interconnection Diagram**

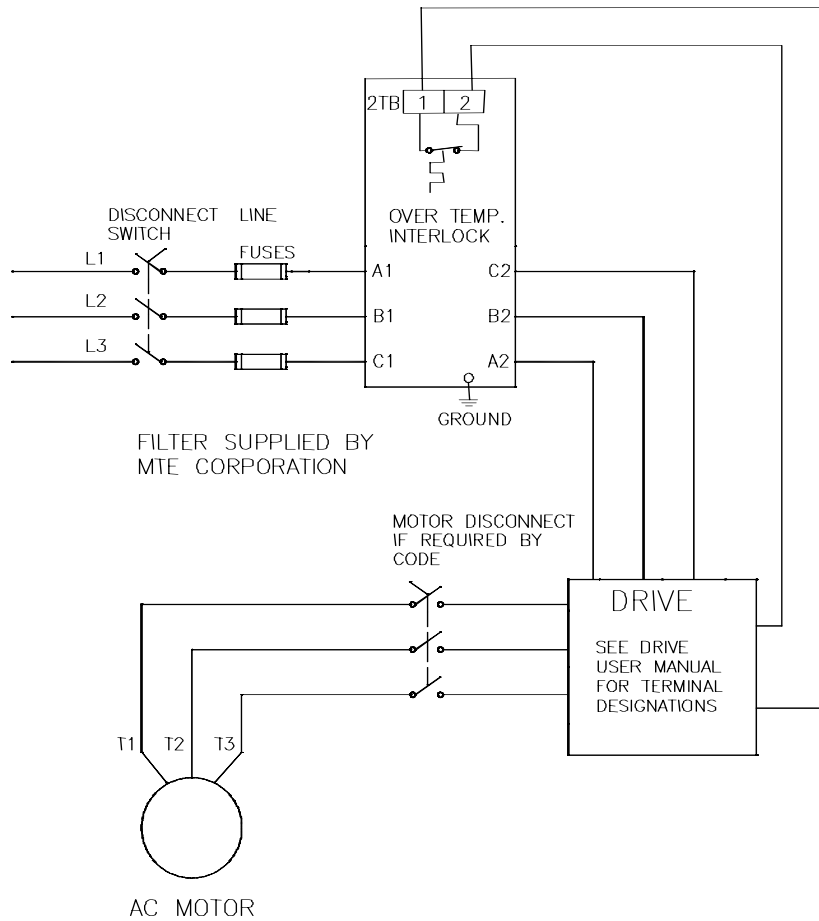
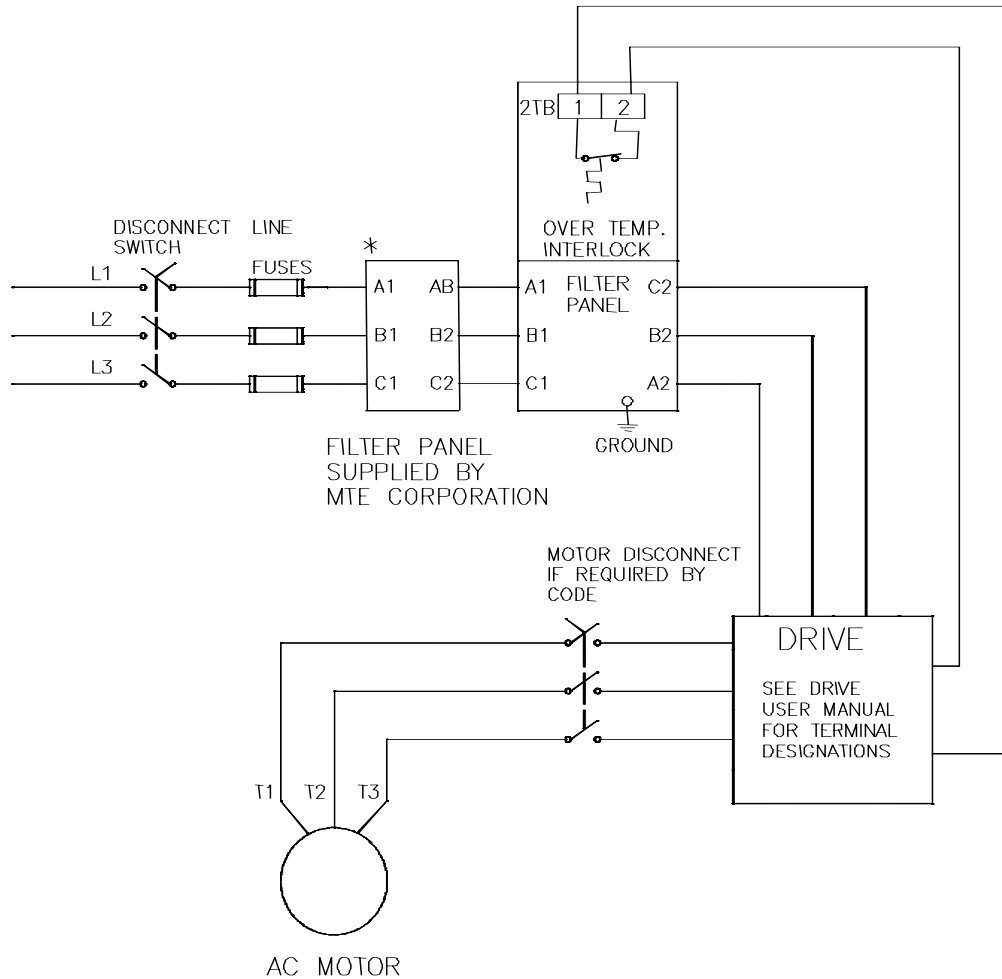


Figure 30

**Filters Mounted in Industrial Style Cabinets
6 – 482 Amps, 480 VAC 60Hz
Interconnection Diagram**

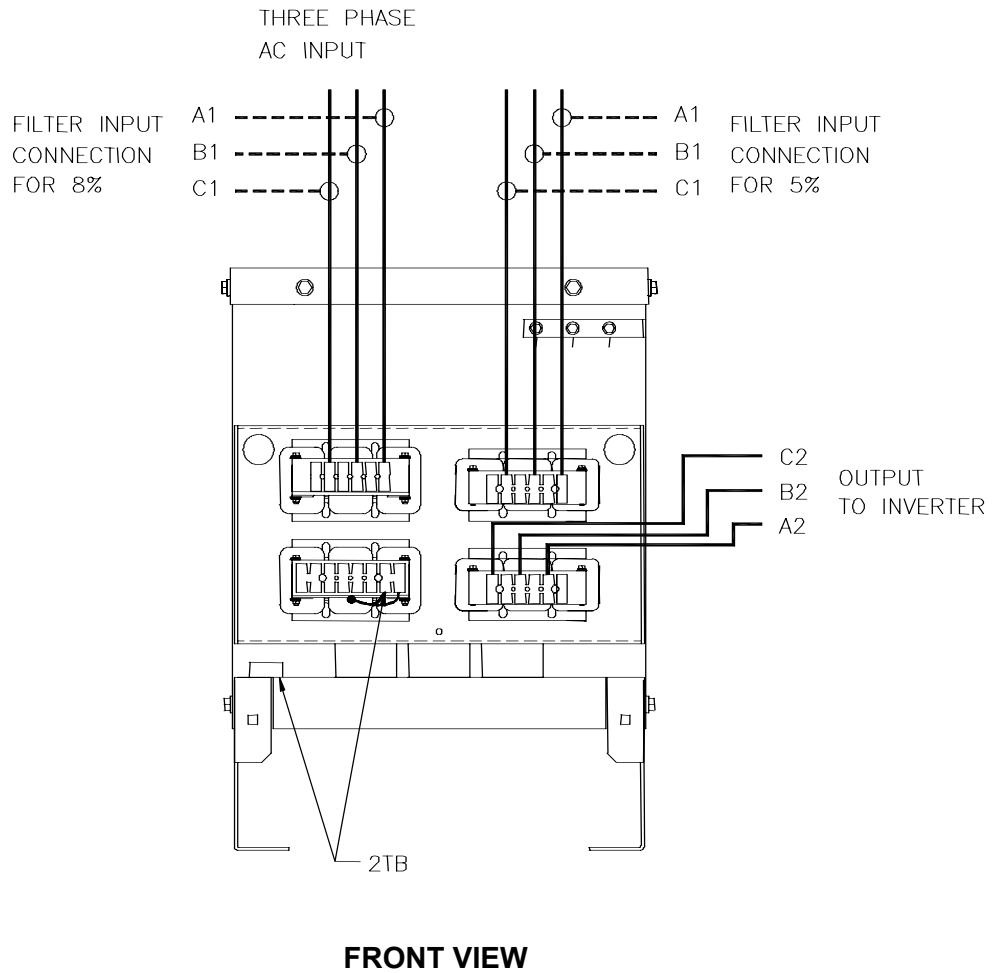


* INPUT REACTOR REQUIRED FOR 5% FILTERS RATED 320 TO 482 AMPS

Figure 31

Terminal Locations NEMA 1-2

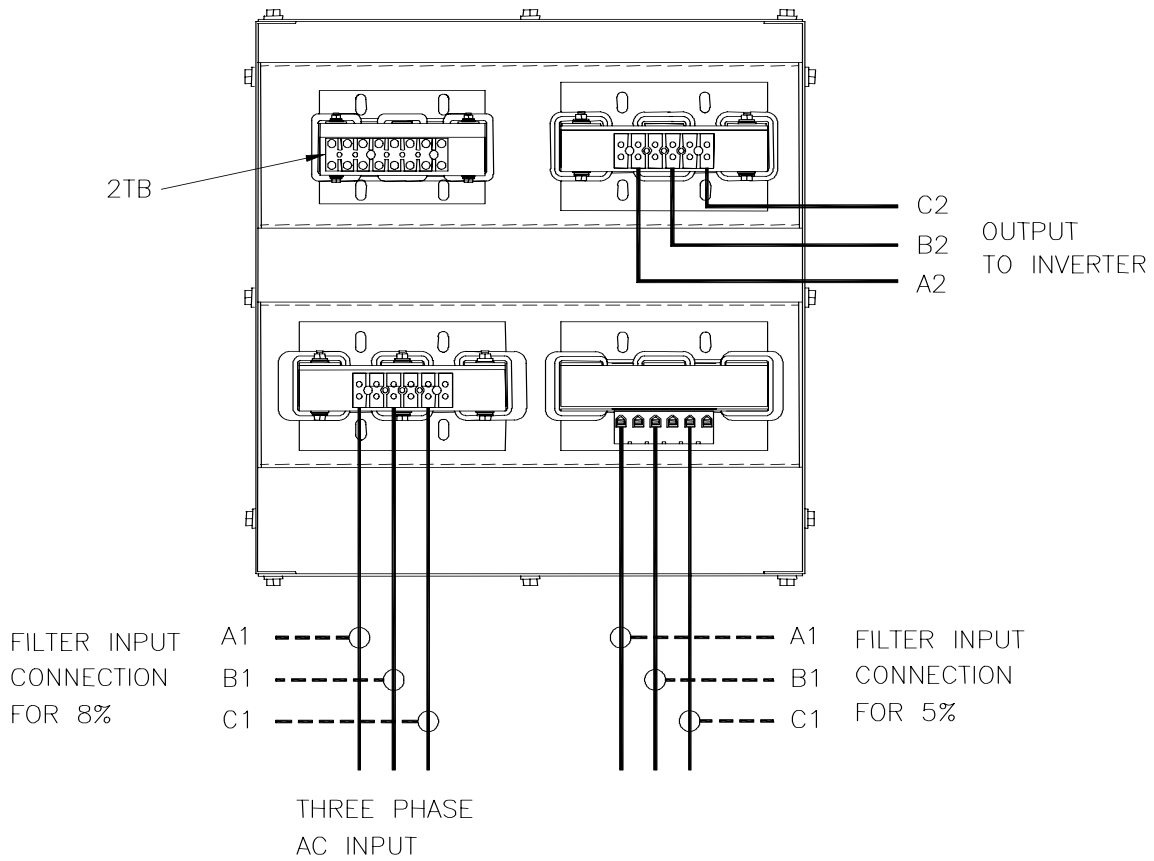
6 – 14 Amps, 480 VAC 60 Hz General Purpose Cabinets



See Figure 29 for Interconnection Diagram

Figure 32

**21 – 52 Amps, 480 VAC 60Hz General Purpose Cabinet
Terminal Locations**

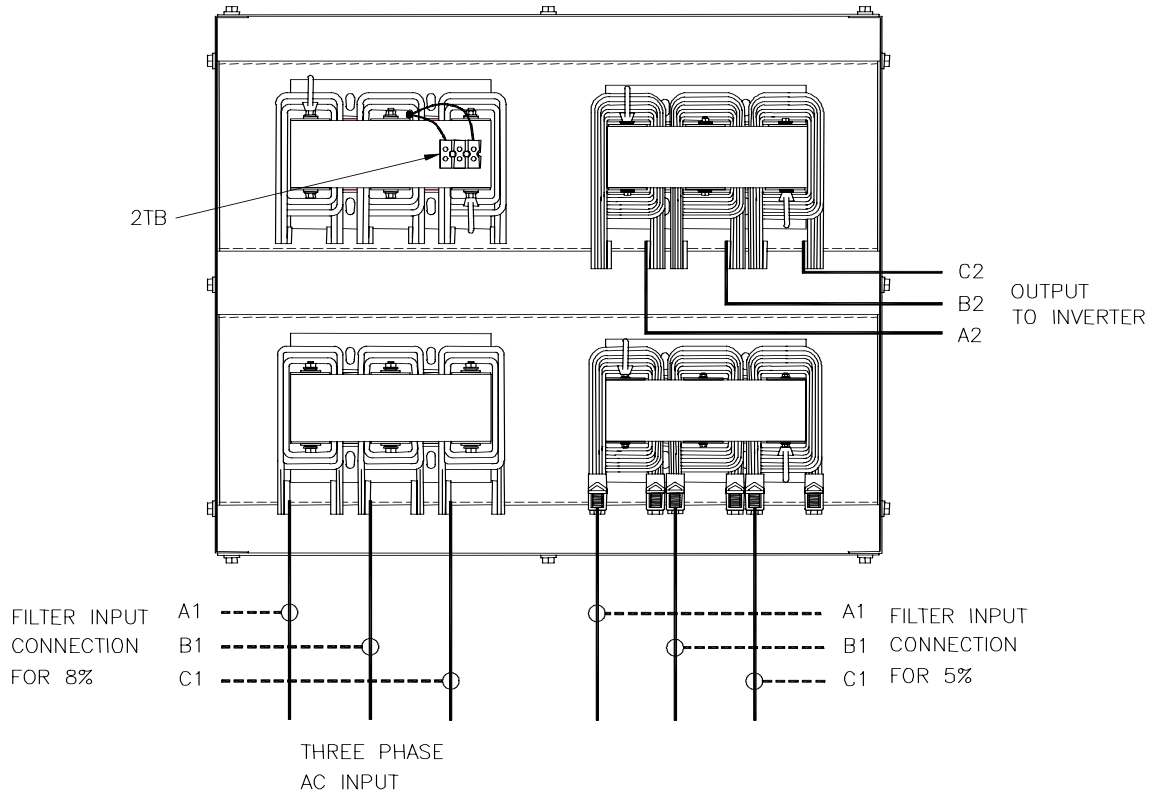


TOP VIEW

See Figure 29 for Interconnection Diagram

Figure 33

**66 – 240 Amps, 480 VAC 60Hz General Purpose Cabinet
Terminal Locations**

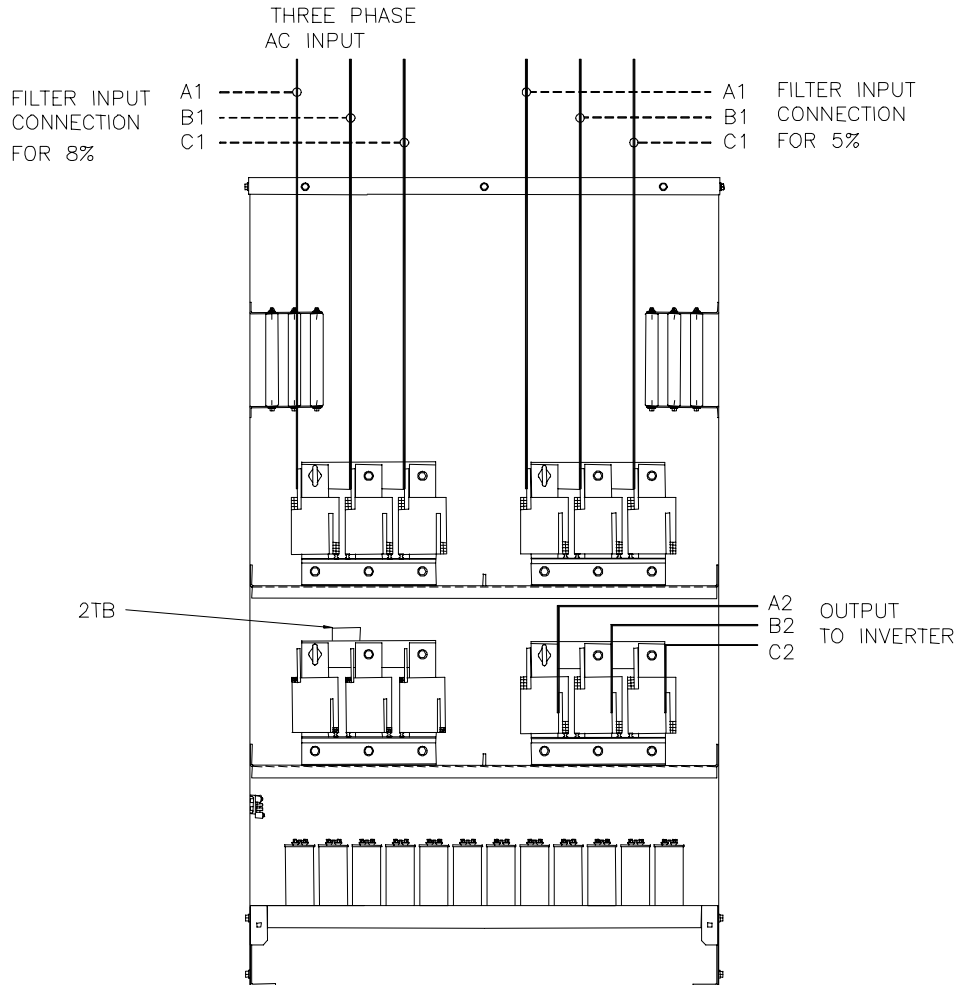


TOP VIEW

See Figure 29 for Interconnection Diagram

Figure 34

**320 – 786 Amps, 480 VAC 60Hz General Purpose Cabinet
Terminal Locations**



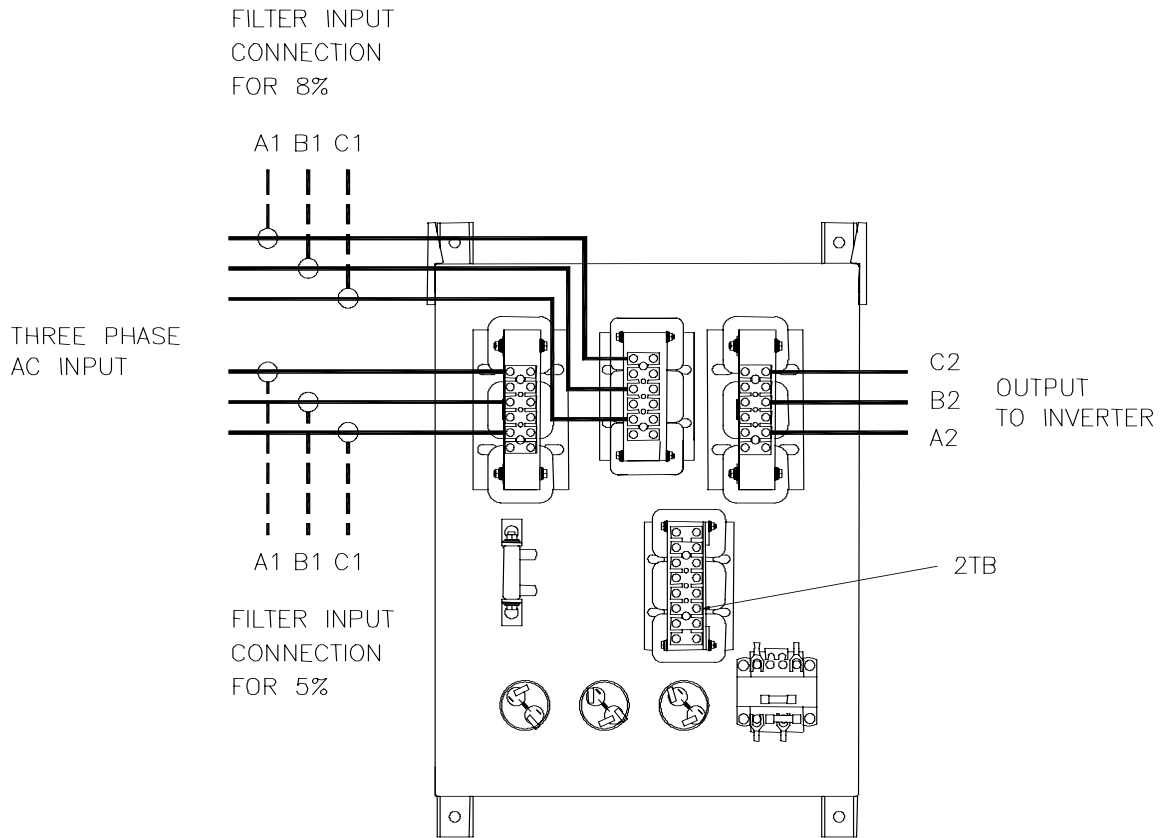
FRONT VIEW

See Figure 29 for Interconnection Diagram

Figure 35

6 – 21 Amps, 480 VAC 60Hz Industrial Enclosures

Terminal Locations



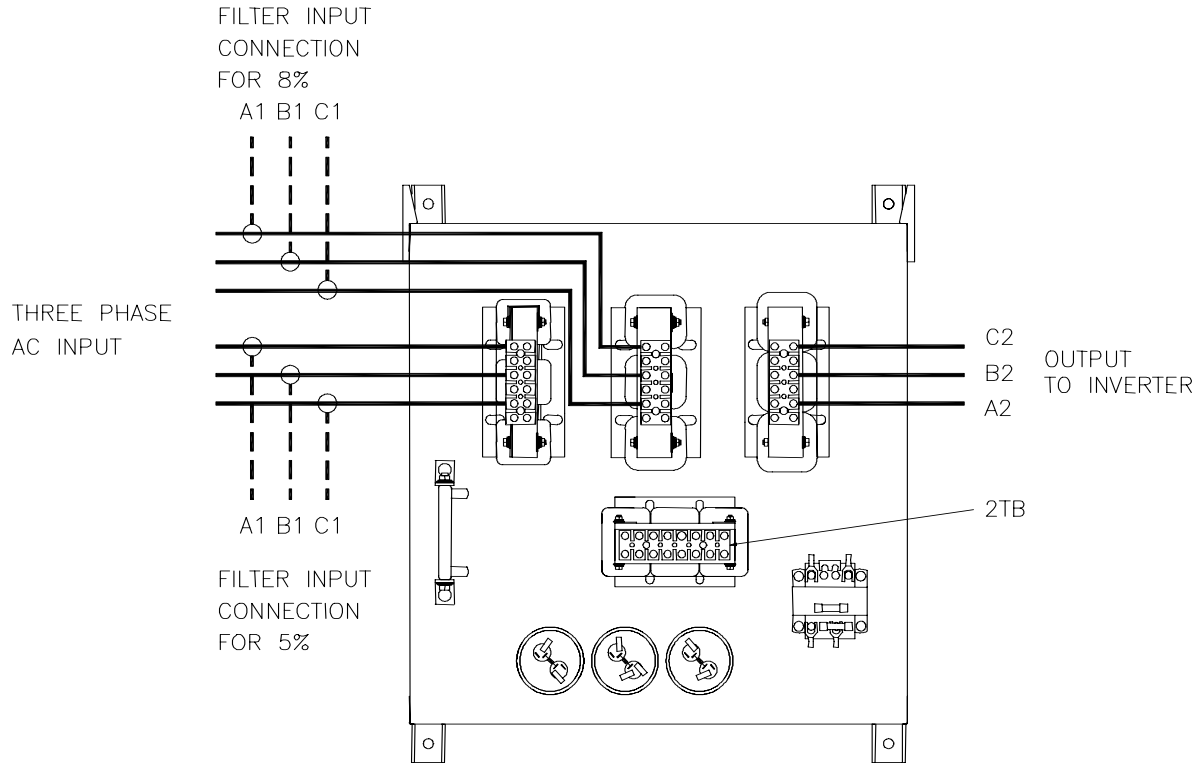
FRONT VIEW

See Figure 30 for Interconnection Diagram

INSTALLATION INSTRUCTIONS - continued

Figure 36

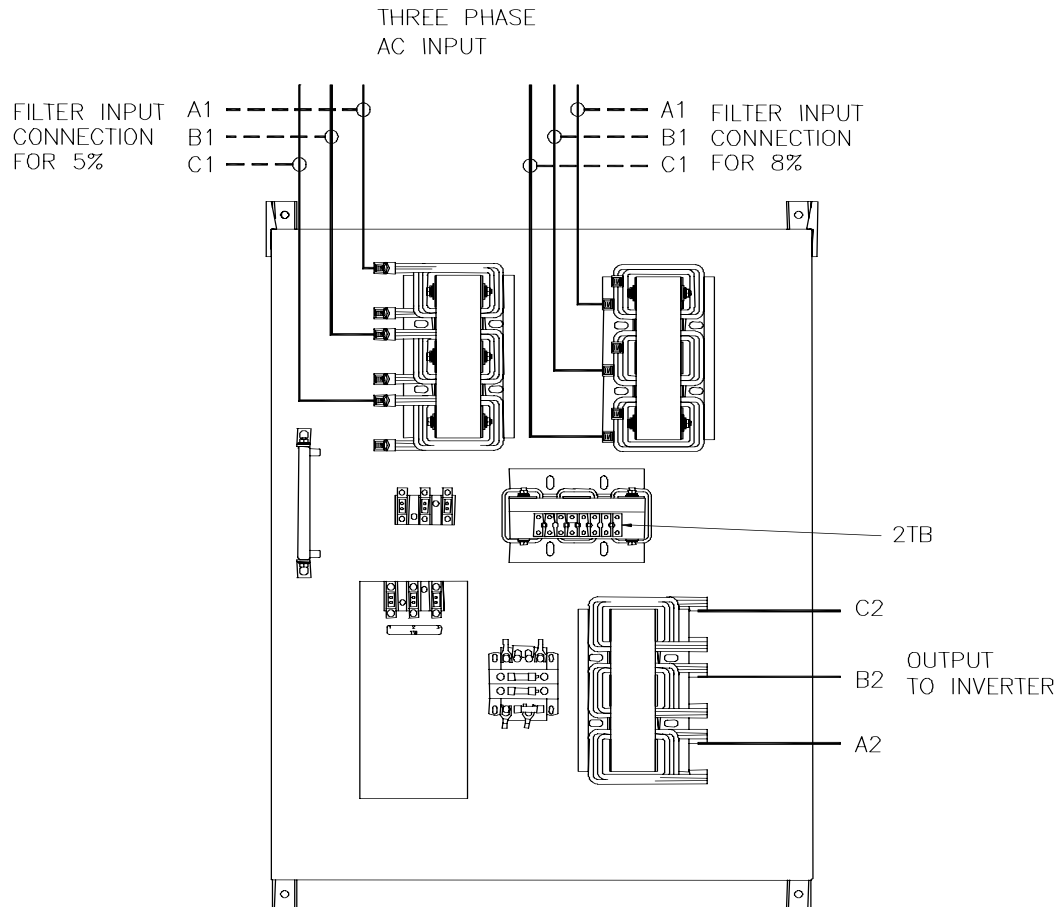
27 – 44 Amps, 480 VAC 60Hz Industrial Enclosures
Terminal Locations



FRONT VIEW

See Figure 30 for Interconnection Diagram

Figure 37
52 – 128 Amps, 480 VAC 60Hz Industrial Enclosures
Terminal Locations

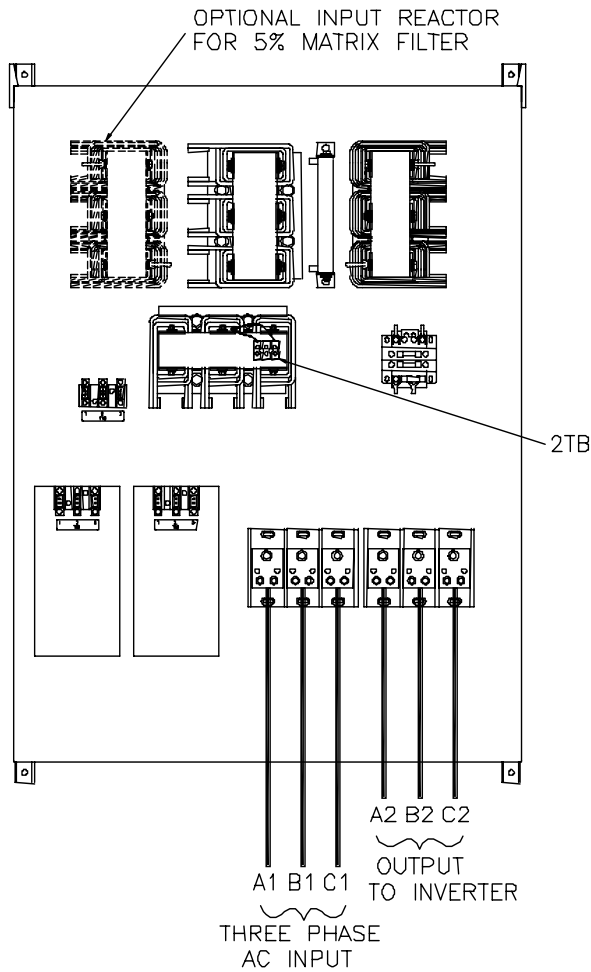


FRONT VIEW

See Figure 30 for Interconnection Diagram

Figure 38

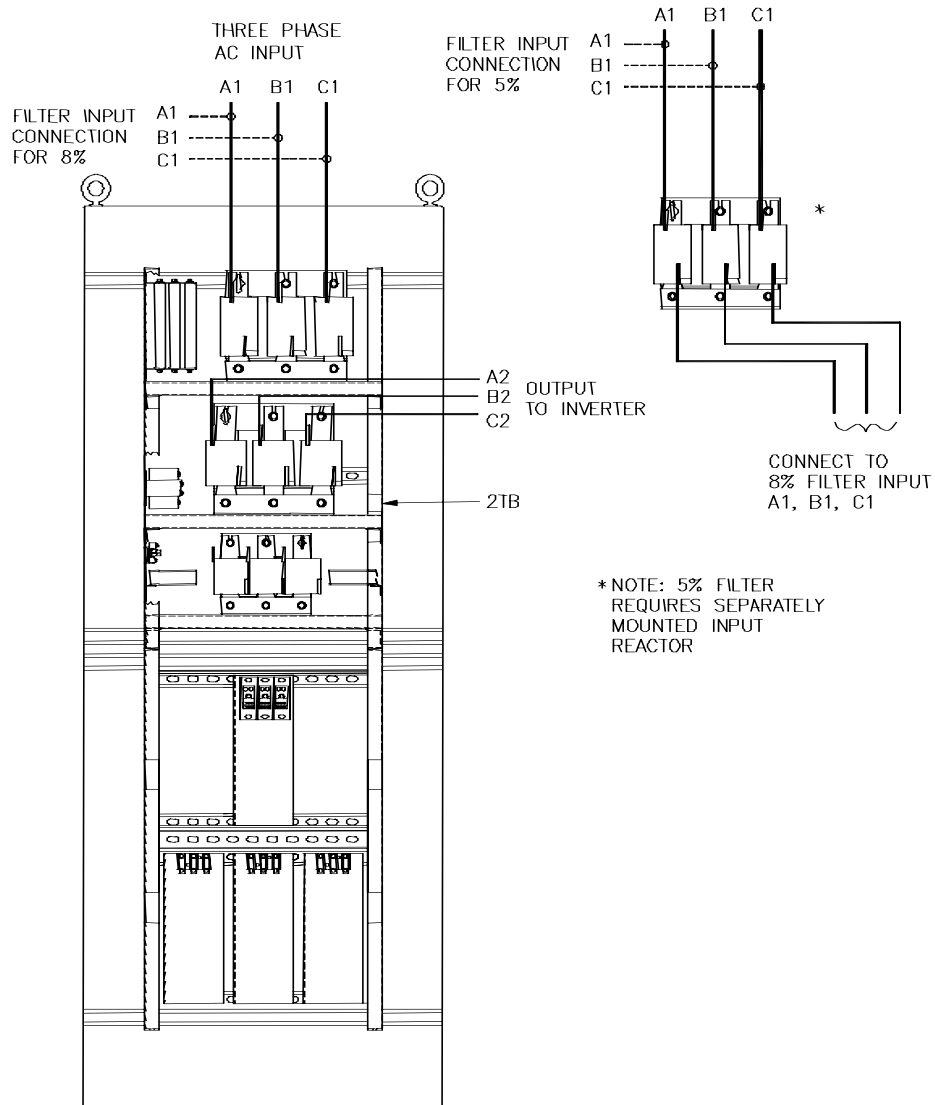
**165 – 240 Amps, 480 VAC 60Hz Industrial Enclosures
Terminal Locations**



FRONT VIEW

See Figure 30 for Interconnection Diagram

Figure 39
320 – 482 Amps, 480 VAC 60Hz Industrial Enclosures
Terminal Locations



FRONT VIEW

See Figure 30 for Interconnection Diagram

6. FILTER DESCRIPTION

The MTE Matrix Filter is a low pass filter containing proprietary technology, which makes it particularly useful for harmonic mitigation of adjustable speed drives. Figure 40 shows a block diagram of the filter. Three phase AC power is connected to the input section which contains a three phase AC reactor and circuitry which inhibits oscillation of the filter with the AC power system. The center leg consists of a series reactor and capacitor bank. Because of the capacitor bank the filter operates with leading power factor at all loads, but unlike trap filters the MTE Matrix Filter does not produce significant voltage rise at the point of common coupling with the power system. The standard 8% filter output section consists of an AC output reactor.

The 5% filter is comprised of a standard 8% filter plus an additional input reactor.

Matrix filters are suitable for use with AC and DC drives and they can be used in both regenerative and non-regenerative applications when properly selected.

Filters for variable torque AC drives rated 7.5 Hp and above should be selected for a filter output current rating greater than or equal to the motor current rating. If the motor current rating is not available, use the NEC motor current rating.

Filters for variable torque AC drives rated 2 – 5 Hp should be selected for a filter output current

rating greater than or equal to 105% of the motor current rating. If the motor current rating is not available, select on the basis of 105% of the NEC motor current rating.

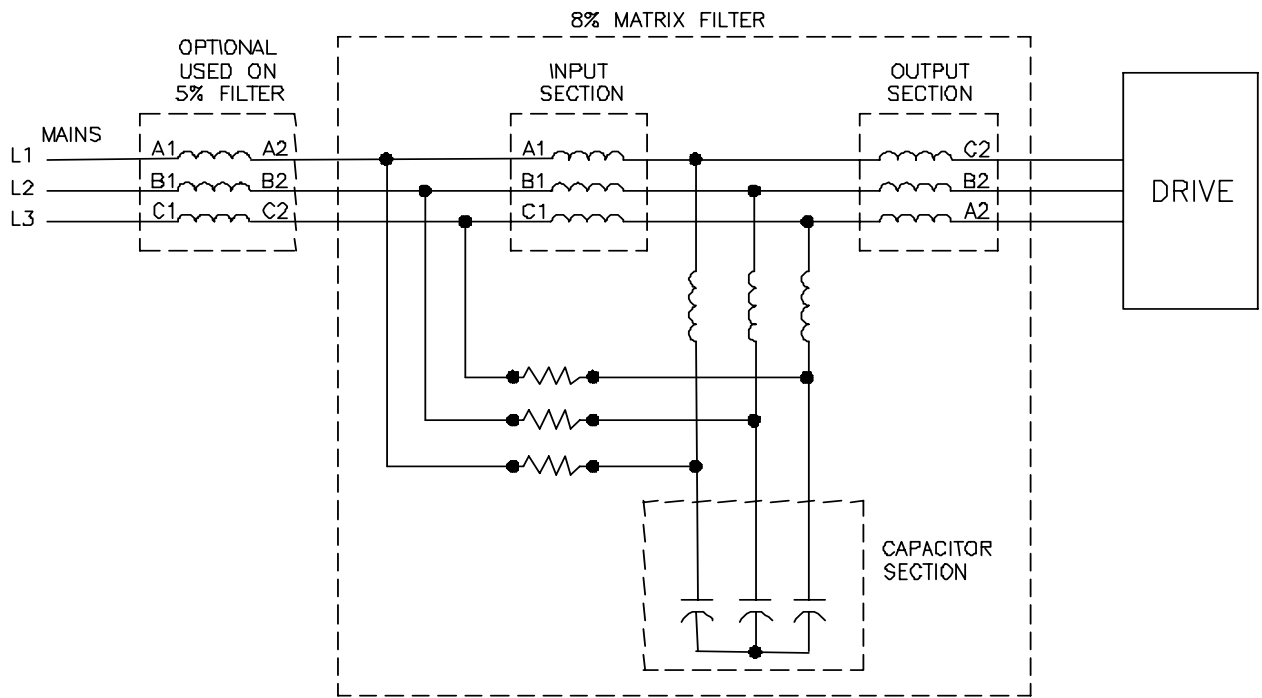
Filters for variable torque AC drives rated less than 1.5 Hp should be selected for an output current rating greater than or equal to 110% of the motor current rating or 110% OF the NEC motor current rating.

For constant torque, AC and DC drive applications operating from six pulse rectifier front ends selected a filter current rating according to application engineering note “Matrix Filter Operation in Constant Torque Applications with Six Pulse Rectifiers” or consult MTE engineering. For phase controlled DC drive applications, select filter current rating per application note “Matrix Filter with Phase Controlled DC Drivers.

Where a single filter is used to feed multiple drives, the output current rating of the filter should be selected to equal the total current rating of the individual drives when calculated according to the instructions above.

Because the filter supplies harmonic currents required by the drive, linear loads (such as space heaters, incandescent lighting and AC motors operated across the line) should not be connected to the output of the filter.

Figure 40
480 VAC 60Hz Block Diagram



7. STARTUP

Safety Precautions

Before startup, observe the following warnings and instructions:

WARNING

Internal components of the filter are at line potential when the filter is connected to the utility. This voltage is extremely dangerous and may cause death or severe injury if you come in contact with it.

WARNING

After disconnecting the utility power, wait at least 5 minutes before doing any work on the filter connections. After removing power, allow at least five minutes to elapse and verify that the capacitors have discharged to a safe level before contacting internal components. Connect a DC voltmeter across the capacitor terminals or terminals 1, 2 and 3 on terminal block 1TB. Start with the meter on the highest scale and progressively switch to a lower scale as the indicated voltage falls below the maximum value of the scale used.

Sequence of Operation

1. Read and follow safety precautions.
2. After installation, ensure that:
 - All filter ground terminals are connected to ground.
 - Power wiring to the utility, drive and motor is in accordance with the installation and connection instructions in Chapter 5.

3. Check that moisture has not condensed on the filter components. If moisture is present, do not proceed with startup until the moisture has been removed.
4. Disconnect the filter output from the drive.
5. Connect the filter to the utility.

WARNING

Use extreme caution to avoid contact with line voltage when checking for power. INJURY OR DEATH MAY RESULT IF SAFETY PRECAUTIONS ARE NOT OBSERVED.

6. Confirm that line voltage is present at the input terminals (A1, B1, C1) of the filter.
7. Confirm that line voltage is present at the output terminals (A2, B2, C2) of the filter.
8. Disconnect the filter from the utility.
9. Connect the filter output to the drive.
10. Refer to the drive user manual for the drive startup procedure. Observe all safety instructions in the drive user manual.

WARNING

INJURY OR DEATH MAY RESULT IF THE DRIVE SAFETY PRECAUTIONS ARE NOT OBSERVED.

CAUTION

Damage to equipment may occur if the drive startup procedures are not observed.

8. TROUBLESHOOTING

WARNING

When properly installed, this equipment has been designed to provide maximum safety for operating personnel. However, hazardous voltages exist within the confines of the enclosure. Servicing should therefore be performed by qualified personnel only and in accordance with OSHA Regulations.

To aid in troubleshooting, a block diagram is shown in Figure 40, and a list of potential problems and solutions are listed below.

WARNING

High voltage is used in the operation of this filter. Use Extreme caution to avoid contact with high voltage when operating, installing or repairing this filter. ***INJURY OR DEATH MAY RESULT IF SAFETY PRECAUTIONS ARE NOT OBSERVED.***

After removing power, allow at least five minutes to elapse and verify that the capacitors have discharged to a safe level before contacting internal components. Connect a DC voltmeter across the capacitor terminals or terminals 1, 2 and 3 on terminal block 1TB. Start with the meter on the highest scale and progressively switch to a lower scale as the indicated voltage falls below the maximum value of the scale used.

PROBLEM:	Line voltage is not present at the filter output terminals.
Possible cause:	Power to the filter is turned off.
Solution:	Turn power on.
Possible cause:	One or more external line fuses are blown.
Solution:	Verify the continuity of line fuses in all phases. Replace as necessary.

TROUBLESHOOTING - continued

PROBLEM:	Harmonic current distortion exceeds 8% on one or more phases at full load.
Possible cause:	On filters rated 52 amps and above, the capacitor assembly has not been connected.
Solution:	Check interconnection of capacitor assembly with reactor panel (Figure 28).
Possible cause:	A capacitor has failed.
Solution:	Inspect the tops of all capacitors for bowing. Replace failed capacitors.
Possible cause:	Source impedance is less than 1.5%.
Solution:	Add a minimum 1.5% impedance line reactor to the filter input
Possible cause:	Input source voltage harmonic distortion.
Solution:	Identify equipment causing harmonic voltage distortion and add filters as required or accept elevated THVD
Possible cause:	Line voltage unbalance exceeds 1%.
Solution:	Balance input line voltage to 1% or less.

PROBLEM:	Harmonic current distortion exceeds 5% on one or more phases at full load.
Possible cause:	The input reactor required for a 5% filter was not installed. (See Figure 40.)
Solution:	Install the required input reactor
Possible cause:	On filters rated 52 amps and above, the capacitor assembly has not been connected.
Solution:	Check interconnection of capacitor assembly with reactor panel (Figure 28).
Possible cause:	A capacitor has failed.
Solution:	Inspect the tops of all capacitors for bowing. Replace failed capacitors.

TROUBLESHOOTING - continued

PROBLEM:	Harmonic current distortion exceeds 5% on one or more phases at full load.
Possible cause:	Source impedance is less than 1.5%.
Solution	Add a minimum 1.5% impedance line reactor to the filter input
Possible cause:	Input source voltage harmonic distortion.
Solution	Identify equipment causing harmonic voltage distortion and add filters as required or accept elevated THVD
Possible cause:	Line voltage unbalance exceeds 1%.
Solution:	Balance input line voltage to 1% or less.

PROBLEM:	Filter output voltage is not within specification
Possible cause:	Filter input voltage is not within specification.
Solution:	Check the AC input line voltage and verify that it is within tolerance. Refer to the filter service conditions and performance specifications in Chapter 3 for tolerances.
Possible cause:	Source impedance is out of tolerance.
Solution:	Verify that the source impedance is within tolerance. Refer to the filter service conditions and performance specifications in Chapter 4 for tolerances.